

Energy Levels of Light Nuclei $A = 6$

F. Ajzenberg-Selove

University of Pennsylvania, Philadelphia, Pennsylvania 19104-6396

Abstract: An evaluation of $A = 5-10$ was published in *Nuclear Physics A490* (1988), p. 1. This version of $A = 6$ differs from the published version in that we have corrected some errors discovered after the article went to press. The introduction and introductory tables have been omitted from this manuscript. [Reference](#) key numbers have been changed to the NNDC/TUNL format.

(References closed June 1, 1988)

The original work of Fay Ajzenberg-Selove was supported by the US Department of Energy [DE-FG02-86ER40279]. Later modification by the TUNL Data Evaluation group was supported by the US Department of Energy, Office of High Energy and Nuclear Physics, under: Contract No. DEFG05-88-ER40441 (North Carolina State University); Contract No. DEFG05-91-ER40619 (Duke University).

Table of Contents for $A = 6$

Below is a list of links for items found within the PDF document. The introductory [Table 2](#) is available on this website via the link.

A. Nuclides: [\${}^6\text{n}\$](#) , [\${}^6\text{H}\$](#) , [\${}^6\text{He}\$](#) , [\${}^6\text{Li}\$](#) , [\${}^6\text{Be}\$](#) , [\${}^6\text{B}\$](#) , [\${}^6\text{C}\$](#)

B. Tables of Recommended Level Energies:

[Table 6.1](#): Energy levels of ${}^6\text{He}$

[Table 6.2](#): Energy levels of ${}^6\text{Li}$

[Table 6.6](#): Energy levels of ${}^6\text{Be}$

C. [References](#)

D. Figures: [\${}^6\text{He}\$](#) , [\${}^6\text{Li}\$](#) , [\${}^6\text{Be}\$](#) , [Isobar diagram](#)

E. Erratum to this Publication: [PS](#) or [PDF](#)

⁶n
(Not illustrated)

⁶n has not been observed: see (1979AJ01). See also (1984DE52) and (1987BE45; theor.).

⁶H
(Fig. 4)

⁶H has been reported in the ⁷Li(⁷Li, ⁸B)⁶H reaction at $E(^7\text{Li}) = 82$ MeV (1984AL08, 1985AL1G) [$\sigma(\theta) \approx 60$ nb/sr at $\theta = 10^\circ$] and in the ⁹Be(¹¹B, ¹⁴O)⁶H reaction at $E(^{11}\text{B}) = 88$ MeV (1986BE35) [$\sigma(\theta) \approx 16$ nb/sr at $\theta \approx 8^\circ$]. ⁶H is unstable with respect to breakup into ³H + 3n by 2.7 ± 0.4 MeV, $\Gamma = 1.8 \pm 0.5$ MeV (1984AL08), 2.6 ± 0.5 MeV, $\Gamma = 1.3 \pm 0.5$ MeV (1986BE35). We adopt 2.7 ± 0.3 MeV, $\Gamma = 1.6 \pm 0.4$ MeV. See also (1987BO40). The atomic mass excess of ⁶H using the (1988WA18) masses for ³H and n, is then 41.9 ± 0.3 MeV. However, there is no evidence for the formation of ⁶H in the ⁶Li(π^- , π^+) reaction at $E_{\pi^-} = 220$ MeV (1987SE1C, 1988SEZJ; prelim.). The ground state of ⁶H is calculated to have $J^\pi = 2^-$. Excited states are predicted at 1.78, 2.80 and 4.79 MeV with $J^\pi = 1^-, 0^-$ and 1^+ [(0+1) $\hbar\omega$ model space] (1985PO10) [see also for (0+2) $\hbar\omega$ calculations]. See also (1986BE44, 1987GOZN), (1983PO1D, 1984AJ01, 1986FL1A, 1987AJ1A, 1987PE1C, 1988HA44) and (1987HA40, 1987KUZI; theor.).

⁶He
(Figs. 1 and 4)

GENERAL: See also (1984AJ01).

Model calculations: (1983GA12, 1983LE14, 1984FI14, 1984PA08, 1984VA06, 1985EM01, 1985FI1E, 1986EM02, 1986FI07, 1986KU08, 1986KU1F, 1986VA13, 1986VO09, 1987DA1H, 1988KA1J).

Special states: (1984FI14, 1984FIZW, 1984VA06, 1985EM01, 1985FI1E, 1986EM02, 1986FI07, 1986KU08, 1986VA13, 1986VO09, 1986WI04, 1987BL18, 1987DA1G, 1987DA1H, 1987KO39, 1987KUZI, 1988DA1E).

Electromagnetic transitions: (1984VA1B, 1985FI1E, 1986FI07).

Complex reactions involving ⁶He: (1982AL33, 1983AN13, 1983KU1B, 1983OL1A, 1984BA1H, 1984GL06, 1984KO1A, 1984LA27, 1984WE03, 1985BA1C, 1985BO1J, 1985JA18, 1985MA02, 1985MA13, 1985WO11, 1986AV1B, 1986CS1A, 1986EN1B, 1986MA1V, 1986SA30, 1986SIZS, 1986WE1C, 1987BA1I, 1987BA38, 1987BA39, 1987BO40, 1987GR11, 1987GU1L, 1987KO1Z, 1987PE1C, 1987TAZU, 1987WI09, 1987YA16, 1988AL1G, 1988LI1A, 1988ST06, 1988TA1A, 1988WO10).

Table 6.1: Energy levels of ${}^6\text{He}$

E_x (MeV \pm keV)	$J^\pi; T$	$\tau_{1/2}$ or Γ_{cm}	Decay	Reactions
g.s.	$0^+; 1$	$\tau_{1/2} = 806.7 \pm 1.5$ ms	β^-	1, 3, 4, 5, 6, 7, 8, 9, 10, 11, 12, 13, 14, 15, 16, 17, 18, 20
1.797 ± 25	$(2)^+; 1$	$\Gamma = 113 \pm 20$ keV	n, α	3, 4, 5, 7, 8, 10, 11, 12, 13, 14, 15, 16, 20
(13.6 ± 500)	$(1^-, 2^-); 1$	broad		4, 11, 14, 16
(15.5 ± 500)		4 ± 2 MeV		5, 6, 10, 11, 15, 16
(25 ± 1000)		8 ± 2 MeV		6
(32)		≤ 2 MeV		15
(36)		≤ 2 MeV		15

Applications: (1985TA1D).

Muon and neutrino capture and reactions: (1983JU01, 1984WA1J).

Reactions involving pions, other mesons and baryon states (see also reactions 4 and 5): (1982BE1D, 1984KO16, 1984RE1C, 1984ZA1A, 1985ER06, 1985RE1B, 1986AK1A, 1986HA1L, 1987FA1H, 1987JA1C).

Hypernuclei: (1982KA1D, 1982MO1B, 1982WA1A, 1983BA1D, 1983MO1C, 1983SH1E, 1984BO1D, 1984BO1G, 1984BO1H, 1984CH1G, 1984DZ1A, 1984KE1C, 1984MI1E, 1984MO1H, 1984ZH1B, 1985BA1E, 1985GU1J, 1985IK1A, 1985MO1F, 1986BO1E, 1986DA1B, 1986PO1G, 1986PO1H, 1986WA1J, 1986ZH1B, 1987BO1L, 1987BO1O, 1987CO1S, 1987DZ1B, 1987JI1A, 1987PO1H, 1987SU1K, 1987WA36, 1987YA1M, 1988GI1B, 1988JI1A, 1988PO1H, 1988TA29).

Fig. 1: Energy levels of ${}^6\text{He}$. In these diagrams, energy values are plotted vertically in MeV, based on the ground state as zero. Uncertain levels or transitions are indicated by dashed lines; levels which are known to be particularly broad are cross-hatched. Values of total angular momentum J , parity, and isobaric spin T which appear to be reasonably well established are indicated on the levels; less certain assignments are enclosed in parentheses. For reactions in which ${}^6\text{He}$ is the compound nucleus, some typical thin-target excitation functions are shown schematically, with the yield plotted horizontally and the bombarding energy vertically. Bombarding energies are indicated in laboratory coordinates and plotted to scale in cm coordinates. Excited states of the residual nuclei involved in these reactions have generally not been shown; where transitions to such excited states are known to occur, a brace is sometimes used to suggest reference to another diagram. For reactions in which the present nucleus occurs as a residual product, excitation functions have not been shown; a vertical arrow with a number indicating some bombarding energy, usually the highest, at which the reaction has been studied, is used instead. Further information on the levels illustrated, including a listing of the reactions in which each has been observed, is contained in the master table, entitled “Energy levels of ${}^6\text{He}$ ”.

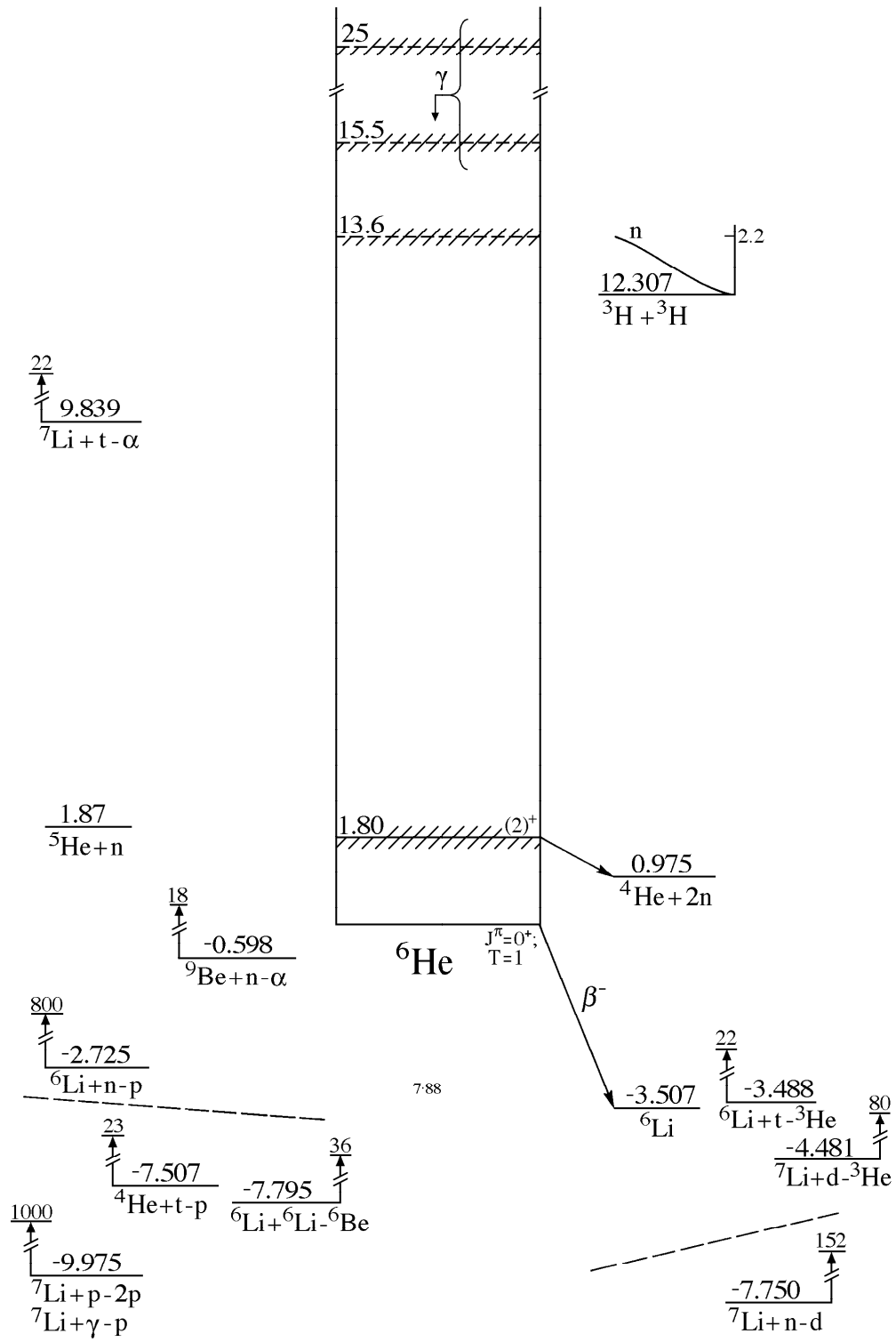

Other topics: (1983BA1L, 1984FI14, 1985AN28, 1986KO1N, 1986KU1F, 1987AJ1A, 1988DA1E).

Ground state of ${}^6\text{He}$: (1983ANZQ, 1983GR26, 1983LE14, 1984FR13, 1984PA08, 1985AN28, 1985FI1E, 1985SA32, 1986KU08, 1986VO09, 1987BL18, 1987HA30, 1987HA34, 1987SA15, 1988DAZW, 1988JO1C).

The interaction nuclear radius of ${}^6\text{He}$ is 2.18 ± 0.02 fm (1985TA18, 1985TA13) [see also for derived nuclear matter, charge and neutron matter rms radii].

1. ${}^6\text{He}(\beta^-){}^6\text{Li}$ $Q_m = 3.507$

The decay proceeds to the ground state of ${}^6\text{Li}$ [$J^\pi = 1^+$] via a super-allowed Gamow-Teller transition. The half-life is 806.7 ± 1.5 msec; $\log ft = 2.910 \pm 0.002$: see (1984AJ01). See also (1986RO27), (1985GR1A) and (1983LE14, 1984BO03, 1984PA08, 1988SA2J; theor.).

2. (a) ${}^3\text{H}(t, n){}^5\text{He}$ $Q_m = 10.44$ $E_b = 12.307$
(b) ${}^3\text{H}(t, 2n){}^4\text{He}$ $Q_m = 11.33216$
(c) ${}^3\text{H}(t, t){}^3\text{H}$

The cross section for reaction (b) has recently been measured for $E_t = 30$ to 115 keV by (1986BR20, 1985JA16) who have also calculated the astrophysical S -factors [the extrapolated $S(0) \approx 180$ keV·b] and discussed the earlier measurements. See also (1974AJ01, 1979AJ01) and (1986JA1E; applied). For muon-catalyzed fusion see (1985ZI1C, 1987BR1V, 1987PO1M). See also (1984BY1A, 1984BY1B, 1984FI1F, 1985BU1B, 1985GU1G, 1985KA1M, 1985VA1B, 1986BA73, 1986BY1A, 1987PR08, 1987WY1A, 1988RYZW; theor.).

3. ${}^4\text{He}(t, p){}^6\text{He}$ $Q_m = -7.507$

Angular distributions of the protons to ${}^6\text{He}^*(0, 1.80)$ have been measured at $E_t = 22$ and 23 MeV. [No L -values were assigned.] No other states are observed with $E_x \leq 4.2$ MeV: see (1979AJ01).

4. ${}^6\text{Li}(e, \pi^+){}^6\text{He}$ $Q_m = -143.075$

(1986SH14) report breaks in (e, π^+) spectra at $E_e = 202$ MeV corresponding to $E_x = 7, 9, 12, 13.6, 17.7$ and 24.0 MeV. Using the shape of the virtual photon spectrum results in groups whose angular distributions suggest that the states at 13.6, 17.7 and 24.0 MeV are spin-dipole isovector

states [$J^\pi = 1^-, 2^-$]. For the earlier work see (1984AJ01). [Note: The states reported here at 7, 9 and 12 MeV are inconsistent with the work reported in reactions 7, 8, 14 and 15, and with the work on the analog region in ${}^6\text{Be}$].

5. (a) ${}^6\text{Li}(\pi^-, \gamma){}^6\text{He}$ $Q_m = 136.062$
 (b) ${}^6\text{Li}(\pi^-, \pi^0){}^6\text{He}$ $Q_m = 1.097$

The excitation of ${}^6\text{He}^*(0, 1.8)$ and possibly of (broad) states at $E_x = 15.6 \pm 0.5$, 23.2 ± 0.7 and 29.7 ± 1.3 MeV has been reported: see (1979AJ01). (1986PE05) have recently studied the capture branching ratios to ${}^6\text{He}^*(0, 1.8)$. For reaction (b) see (1984AJ01).

6. ${}^6\text{Li}(n, p){}^6\text{He}$ $Q_m = -2.725$

Angular distributions of the p_0 group have been reported at $E_n = 4.7$ to 6.8 MeV, at 14 MeV and at 59.6 MeV [see (1979AJ01, 1984AJ01)] and at 118 MeV (1987PO18; prelim.). At $E_n = 59.6$ MeV broad structures in the spectra are ascribed to states at $E_x = 15.5 \pm 0.5$ and 25 ± 1 MeV with $\Gamma = 4 \pm 1.5$ and 8 ± 2 MeV (1983BR32, 1984BR03) [see for discussions of the GDR strength]. The ground state reaction has also been studied at $E_n = 198$ MeV (1988JA01). See also (1986ALZJ, 1986POZX, 1988MIZX), (1986AU1D, 1987BR32, 1987HE22, 1988HA12) and (1983GM1A, 1985ER06, 1986ER1A; theor.).

7. ${}^6\text{Li}(d, 2p){}^6\text{He}$ $Q_m = -4.949$

At $E_d = 55$ MeV, ${}^6\text{He}^*(0, 1.8)$ [the latter weak] are populated: no other states are observed with $E_x \leq 25$ MeV [see (1984AJ01)].

8. ${}^6\text{Li}(t, {}^3\text{He}){}^6\text{He}$ $Q_m = -3.488$

The ground-state angular distribution has been studied at $E_t = 17$ MeV. At $E_t = 22$ MeV only ${}^6\text{He}^*(0, 1.8)$ are populated for $E_x \leq 8.5$ MeV: see (1979AJ01). Differential cross sections for the transition to ${}^6\text{He}^*(1.8)$ are reported at $E({}^6\text{Li}) = 65$ MeV (1987AL23).

9. ${}^6\text{Li}({}^6\text{Li}, {}^6\text{Be}){}^6\text{He}$ $Q_m = -7.795$

Angular distributions have been studied for $E(^6\text{Li}) = 32$ and 36 MeV for the transitions to $^6\text{He}_{\text{g.s.}}$, $^6\text{Be}_{\text{g.s.}}$ and, in inelastic scattering of ^6Li [see ^6Li], to the analog state $^6\text{Li}^*(3.56)$: for a discussion of these see the references quoted in (1979AJ01).

$$\begin{aligned} 10. \text{ (a) } ^7\text{Li}(\gamma, \text{p})^6\text{He} & \quad Q_{\text{m}} = -9.975 \\ \text{ (b) } ^7\text{Li}(\text{e}, \text{ep})^6\text{He} & \quad Q_{\text{m}} = -9.975 \end{aligned}$$

At $E_{\gamma} = 60$ MeV, the proton spectrum shows two prominent peaks attributed to $^6\text{He}^*(0 + 1.8, 18 \pm 3)$: see (1979AJ01). Reactions (a) and (b) have been studied by (1985SE17). See also ^7Li , (1984AJ01) and (1986BA2G; theor.).

$$11. ^7\text{Li}(\text{n}, \text{d})^6\text{He} \quad Q_{\text{m}} = -7.750$$

At $E_{\text{n}} = 60$ MeV, the deuteron spectrum shows two prominent peaks attributed to states centered at $E_{\text{x}} = 13.6, 15.4$ and 17.7 MeV (± 0.5 MeV) and a possible state or states (populated with an l_{p} transfer ≥ 2) at $E_{\text{x}} = 23.7$ MeV. DWBA analyses of the d_0 and d_1 groups are consistent with $l_{\text{p}} = 1$ and $S(1\text{p}_{3/2}) = 0.62$ for $^6\text{He}_{\text{g.s.}}$ and to $S(1\text{p}_{3/2}) = 0.37, S(1\text{p}_{1/2}) = 0.32$ for $^6\text{He}^*(1.8)$: see (1979AJ01).

$$12. ^7\text{Li}(\text{p}, 2\text{p})^6\text{He} \quad Q_{\text{m}} = -9.975$$

At $E_{\text{p}} = 1$ GeV the separation energy between 6–7 MeV broad $1\text{p}_{3/2}$ and $1\text{s}_{1/2}$ peaks is reported to be 14.1 ± 0.7 MeV (1985BE30, 1985DO16). See also (1983GO06) and (1979AJ01).

$$13. ^7\text{Li}(\text{d}, ^3\text{He})^6\text{He} \quad Q_{\text{m}} = -4.481$$

Angular distributions of the ^3He ions to $^6\text{He}^*(0, 1.8)$ have been measured at $E_{\text{d}} = 14.4$ and 22 MeV: they have an $l_{\text{p}} = 1$ character and therefore these two states have $J^{\pi} = (0-3)^+$. There is no evidence for any other states of ^6He with $E_{\text{x}} < 10.7$ MeV: see (1979AJ01). (1987BO39) [$E_{\text{d}} = 30.7$ MeV] deduce that the branching ratio of $^6\text{He}^*(1.8)$ into a dineutron [$n^2: T = 1, S = 0$] and an α -particle is 0.75 ± 0.10 . See also (1985BO55) and (1987DA31; theor.).

$$14. ^7\text{Li}(\text{t}, \alpha)^6\text{He} \quad Q_{\text{m}} = 9.839$$

The energy of the first-excited state is 1.797 ± 0.025 MeV, $\Gamma = 113 \pm 20$ keV. ${}^6\text{He}^*(1.80)$ decays into ${}^4\text{He} + 2n$. The branching ratio $\Gamma_\gamma/\Gamma_\alpha \leq 2 \times 10^{-6}$: for $\Gamma_{\text{c.m.}} = 113 \pm 20$ keV, $\Gamma_\gamma \leq 0.23$ eV. Angular distributions of the α_0 and α_1 groups have been measured at $E_t = 13$ and 22 MeV. No other α -groups are reported corresponding to ${}^6\text{He}$ states with $E_x < 24$ MeV (region between $E_x \approx 13$ and 16 MeV was obscured by the presence of breakup α -particles): see (1979AJ01). Angular distributions have been recently reported at $E_t = 0.151$ and 0.272 MeV (1987AB09; α_0 , α_1) and at $E({}^7\text{Li}) = 31$ MeV. (1987AL23; to ${}^6\text{He}^*(0, 1.8, 13.6)$).

$$15. {}^7\text{Li}({}^3\text{He}, \text{p}^3\text{He}){}^6\text{He} \quad Q_m = -9.975$$

At $E({}^3\text{He}) = 120$ MeV the missing mass spectra show ${}^6\text{He}^*(0, 1.8)$ and a strong, broad peak corresponding to ${}^6\text{He}^*(16)$ [possibly due to unresolved states]. There is no indication of a state near 23.7 MeV but there is some evidence of structures at $E_x = 32.0$ and 35.7 MeV, with $\Gamma \leq 2$ MeV (1985FR01).

$$16. \text{(a) } {}^7\text{Li}({}^6\text{Li}, {}^7\text{Be}){}^6\text{He} \quad Q_m = -4.369$$

$$\text{(b) } {}^7\text{Li}({}^7\text{Li}, {}^8\text{Be}){}^6\text{He} \quad Q_m = 7.280$$

In reaction (a) at $E({}^6\text{Li}) = 93$ MeV a broad peak ($\Gamma = 5.5$ MeV) is reported at $E_x = 14$ MeV. A second structure may also be present at 15.5 MeV (1987GLZW, 1988BUZH; prelim.). ${}^6\text{He}^*(0, 1.8)$ are also populated (1988BUZH). For reaction (b) see ${}^8\text{Be}$. See also ${}^7\text{Be}$, (1984AJ01), (1988BU1Q) and (1984BA53; theor.).

$$17. {}^9\text{Be}(n, \alpha){}^6\text{He} \quad Q_m = -0.598$$

Angular distributions have been reported for $E_n = 12.2$ to 18.0 MeV (α_0 , α_1). No other states are observed with $E_x \leq 7$ MeV: see (1979AJ01). For a study of possible dineutron breakup of ${}^6\text{He}^*(1.8)$ see (1983OT02). See also ${}^{10}\text{Be}$ and (1983SH1J).

$$18. {}^9\text{Be}({}^6\text{Li}, {}^9\text{B}){}^6\text{He} \quad Q_m = -4.575$$

See ${}^9\text{B}$.

$$19. {}^{10}\text{B}(n, \text{p}\alpha){}^6\text{He} \quad Q_m = -7.184$$

Not observed: see (1984TU02).

$$20. \text{}^{11}\text{B}(\text{}^7\text{Li}, \text{}^{12}\text{C})\text{}^6\text{He} \quad Q_m = 5.983$$

At $E(^{11}\text{B}) = 88$ MeV the population of the ground state and the first-excited state at $E_x = 1.8 \pm 0.3$ MeV ($\Gamma \leq 0.2$ MeV) is reported (1987BEYI). See also (1988BEYJ).

${}^6\text{Li}$
(Figs. 2 and 4)

GENERAL: See also (1984AJ01).

Shell model: (1983LE14, 1983VA31, 1984AS07, 1984PA08, 1984REZZ, 1984VA06, 1984ZW1A, 1985ER06, 1985FI1E, 1985LO1A, 1986AV08, 1986LE21, 1987KI1C, 1988WO04).

Cluster and α -particle models: (1981PL1A, 1982WE15, 1983CA13, 1983DZ1A, 1983FO03, 1983GA12, 1983GO17, 1983SA39, 1983SM04, 1984BE37, 1984CO08, 1984DU17, 1984GL02, 1984JO1A, 1984KH05, 1984KR10, 1984KU03, 1984LA33, 1984MI1F, 1984PA08, 1984PL1A, 1984WA02, 1984WA1H, 1985BE60, 1985BO05, 1985BO11, 1985FI1E, 1985KH07, 1985KW02, 1985KW03, 1985LE08, 1985LI1F, 1985LO02, 1985ME02, 1985OS03, 1985SA1B, 1985ZH1A, 1986AV08, 1986BU07, 1986CHZX, 1986ESZY, 1986FI07, 1986GE05, 1986KR12, 1986KR1E, 1986KU08, 1986KU1F, 1986SA15, 1986SA1D, 1986SR02, 1986VA13, 1986VO09, 1987IM04, 1987KR07, 1987LE33, 1987LO16, 1987TA06, 1987ZH1E, 1988CH05, 1988CO1B, 1988FR1E, 1988KA1J, 1988KU1C, 1988US1A).

Special states: (1981PL1A, 1983BI1C, 1983RO12, 1983VA31, 1984AS07, 1984DU17, 1984FI14, 1984FIZW, 1984OH01, 1984REZZ, 1984VA06, 1984WA02, 1984ZW1A, 1985AL12, 1985BA68, 1985BE60, 1985FI1E, 1985GO07, 1985KW03, 1985ME02, 1985MI10, 1985OS03, 1985PO09, 1985WI1A, 1985ZH1A, 1986AK1C, 1986BU07, 1986EL1A, 1986FI07, 1986GE05, 1986KU08, 1986SA15, 1986VA13, 1986VO09, 1987KI1C, 1987KO39, 1987KR07, 1987KUZI, 1987SV1A, 1987WA36, 1987ZH1E, 1988US1A).

Electromagnetic transitions and giant resonances: (1983GM1A, 1984AS07, 1985FI1E, 1985GO23, 1985ME02, 1986AK1C, 1986ER1A, 1986FI07, 1986ME13, 1986SR02, 1986VA13, 1987KI1C, 1987KR07, 1987ZH1E).

Astrophysical questions: (1982AU1A, 1982CA1A, 1982GR1A, 1982WA1B, 1984RA1E, 1984TR1C, 1985BO1E, 1985BO1K, 1985HO1A, 1985MI1E, 1985SC1C, 1985WA1K, 1986HU1D, 1986LA27, 1986RE1C, 1987AL1C, 1987AR1J, 1987AR1C, 1987AU1A, 1987HO1M, 1987MA2C, 1987PA1F, 1987RO25, 1988RE1B).

Complex reactions involving ${}^6\text{Li}$: (1983CH23, 1983GU1A, 1983GU1B, 1983KU1B, 1983MA53, 1983MU08, 1983NA08, 1983OL1A, 1983SA39, 1983ST1A, 1984BA1H, 1984BE1E, 1984CO08, 1984EC01, 1984EV1A, 1984GO03, 1984GR08, 1984HI1A, 1984KH05, 1984MO29, 1984NE1A, 1984RE14, 1984ST1B, 1984TS03, 1984UM04, 1985BO11, 1985FA02, 1985GL06, 1985GO20, 1985GU11, 1985JA18, 1985MA02, 1985MA13, 1985MO17, 1985MO24, 1985PO09, 1985ST1B, 1985WI1A, 1985WO11, 1986CH10, 1986CS1A, 1986HA1B, 1986JO1A, 1986KA1C, 1986KA1R, 1986LIZP, 1986ME06, 1986RA02, 1986SA1K, 1986SA1N, 1986SA30, 1986SAZJ, 1986SAZK, 1986SAZL, 1986SIZS, 1986SR02, 1986TA1G, 1986TA1M, 1986WE1C, 1986XU1B, 1986YA1L, 1987AR19, 1987AU1C, 1987BA38, 1987BA39, 1987BL13, 1987BL1K, 1987CH08, 1987CH26, 1987CH33, 1987CH32, 1987DE37, 1987DO13, 1987DU07, 1987FA01, 1987FA02, 1987FE1A, 1987FR1G, 1987GE1B, 1987GL05, 1987GR11, 1987HA45, 1987JA06, 1987JE03, 1987KO15,

Table 6.2: Energy levels of ${}^6\text{Li}$

E_x (MeV \pm keV)	$J^\pi; T$	Γ_{cm} (MeV)	Decay	Reactions
g.s.	$1^+; 0$		stable	1, 2, 3, 4, 7, 8, 9, 10, 11, 12, 13, 14, 15, 16, 17, 18, 19, 20, 21, 22, 23, 24, 25, 26, 27, 28, 29, 30, 31, 32, 33, 34, 35, 36, 37, 38, 40, 41, 42, 43, 44, 45, 46, 47, 48, 49, 50, 51, 52, 53, 54
2.186 ± 2	$3^+; 0$	0.024 ± 0.002	γ, d, α	1, 2, 3, 6, 7, 8, 12, 13, 14, 15, 16, 18, 19, 20, 21, 24, 25, 28, 29, 30, 31, 32, 33, 35, 37, 39, 40, 41, 42, 48, 49
3.56288 ± 0.10	$0^+; 1$	$(8.2 \pm 0.2) \times 10^{-6}$	γ	1, 3, 11, 12, 13, 15, 16, 17, 18, 20, 29, 31, 32, 33, 35, 37, 54
4.31 ± 22	$2^+; 0$	1.7 ± 0.2^a	γ, d, α	1, 6, 12, 13, 15, 16, 24, 31, 35, 48
5.366 ± 15	$2^+; 1$	0.540 ± 0.020	γ, n, p, α	1, 12, 15, 31, 32, 33, 35
5.65 ± 50	$1^+; 0$	1.5 ± 0.2	d, α	6, 15, 33, 35
(15.8)	$3^+; 0$	17.8 ± 0.8	d, α	6
21.0	$2^-; 1$	broad	$t, {}^3\text{He}$	1
21.5	$0^-; 1$	broad	$t, {}^3\text{He}$	1
(23 ± 2000)	$4^+; 0$	12 ± 2	d, α	1, 6
25.0 ± 1000	$4^-; 1$	≈ 4	$\gamma, n, t, {}^3\text{He}$	1
26.6 ± 400^b	$3^-; 0$	broad	$\gamma, n, d, t, {}^3\text{He}, \alpha$	1
(31)	(3^+)	broad	$d, t, {}^3\text{He}, \alpha$	1

^a See also Tables 6.4 and 6.5.

^b See also Table 6.3. For other possible states at high E_x see reactions 6, 31, 33 and 38.

1987LY04, 1987LY1D, 1987NA01, 1987PO23, 1987RO10, 1987SA21, 1987TAZU, 1987TR05, 1987VE1D, 1987WA09, 1987YA16, 1988BE09, 1988BL09, 1988CA06, 1988CEZZ, 1988FR1B, 1988FR1F, 1988GO1H, 1988KI05, 1988RU01, 1988SA19, 1988SH1E, 1988ST06, 1988TA1A, 1988TS03, 1988VA1E, 1988WO10).

Polarization of ${}^6\text{Li}$ (See also “Complex reactions” and “Applications”): (1984JO1A, 1984NI01, 1986CH1Q, 1986SA15, 1986TA1G, 1987FI1D, 1988FR1E).

Applications: (1983AM1A, 1983AS03, 1986AU1A, 1986CL1C, 1986EN1A, 1986FI1D, 1986MA1S, 1986SA1M, 1986ST1E, 1986SU1K, 1986ZA1C, 1987DO07).

Muon and neutrino capture and reactions: (1983GM1A, 1983GU10, 1983JU01, 1983MI14, 1984RO1B, 1984WA1J, 1987KU23, 1987SU06).

Reactions involving pions, other mesons and baryon states (See also reactions 3, 13, 29 and 30): (1982BE1D, 1982RA28, 1983AB1B, 1983AS1B, 1983BA26, 1983BA1A, 1983BA1G, 1983DZ1A, 1983FE07, 1983GE12, 1983GM1A, 1983HE17, 1983LO10, 1983PO1D, 1984ABZY, 1984BA1U, 1984BO1H, 1984BR22, 1984EF03, 1984GE1B, 1984GL02, 1984GL09, 1984JI03, 1984KO16, 1984KR10, 1984KU13, 1984MO09, 1984MO1H, 1984NA1D, 1984RE1C, 1984TR1B, 1984ZA1A, 1985BE1C, 1985CA1B, 1985DO19, 1985ER06, 1985LA20, 1985MA1G, 1985MO1F, 1985RE1B, 1985RO17, 1985ST1A, 1986AK1A, 1986AS1A, 1986BA1W, 1986CE04, 1986CH1I, 1986ER1A, 1986FI1A, 1986GE05, 1986HA1L, 1986HU1B, 1986PE05, 1986RA1J, 1986RO03, 1986SH14, 1986SZ1A, 1986WH01, 1986YO06, 1986ZO1A, 1987BE2A, 1987BO1P, 1987BU20, 1987CH10, 1987GM02, 1987GM04, 1987HA40, 1987JA1C, 1987LE1E, 1987LE1B, 1987MA1I, 1987NA04, 1987PO1H, 1987RA1I, 1987SE1C, 1987WE1A, 1987YO01, 1988BA1F, 1988BA1G, 1988FR1E, 1988GA1A, 1988GIZT, 1988GIZU, 1988KA1J, 1988ROZZ).

Reactions involving antiprotons: (1984GU06, 1985DU05, 1985LE1B, 1986DU10, 1986KO1E, 1987AS06, 1987GR1I, 1987PO05).

Hypernuclei: (1982KA1D, 1982MO1B, 1983FE07, 1983MA1F, 1983MO1C, 1983PO1D, 1983SH38, 1984BO1H, 1984HA1D, 1984MA1G, 1984MO09, 1985MO1F, 1986BA1W, 1986ER1A, 1986HU1B, 1986MA1C, 1986SZ1A, 1987PO1H, 1988BA1F, 1988BA1G, 1988GA1A, 1988HA44).

Other topics: (1983BI1C, 1983FO03, 1983RO12, 1984FI14, 1984NA19, 1984OH01, 1985AN28, 1985GO07, 1985GO23, 1985MI10, 1985PO09, 1986KO1N, 1986KU1F, 1986MA1X, 1987AJ1A, 1987SV1A, 1988HA1K).

Ground-state properties of ${}^6\text{Li}$: (1983ANZQ, 1983FO03, 1983GR26, 1983KU06, 1983LE14, 1983VA31, 1984BE37, 1984BR25, 1984DU17, 1984GE05, 1984GL02, 1984KO1H, 1984KU03, 1984KU06, 1984MI1A, 1984MI1F, 1984MIZM, 1984NI01, 1984OH01, 1984PA08, 1985AL12, 1985AN28, 1985BE60, 1985BO05, 1985CL1A, 1985FI1E, 1985HA18, 1985KH07, 1985LO1A, 1985ME02, 1985SA32, 1985SH1A, 1985WI1A, 1985ZH1A, 1985ZI05, 1986ESZY, 1986GL1A, 1986KO1U, 1986KU08, 1986LA27, 1986LE21, 1986ME13, 1986OS07, 1986RO03, 1986SY1A, 1986VO09, 1987HA34, 1987KI1C, 1987KR07, 1987LE1C, 1987LO16, 1987SV1A, 1988CH05, 1988CO1B, 1988POZS, 1988VA03, 1988WO04).

$$\mu = +0.8220467(6) \text{ nm}, +0.8220560(4) \text{ nm: see (1978LEZA),}$$

$$Q = -0.83 \text{ mb (1984SU09).}$$

The interaction nuclear radius of ${}^6\text{Li}$ is $2.09 \pm 0.02 \text{ fm}$ (1985TA18) [see also for derived matter, charge and neutron matter rms radii].

Isotopic abundance: $(7.5 \pm 0.2)\%$ (1984DE53). See also (1987LA1J, 1988LA1C).

For estimates of the parity-violating α -decay width of ${}^6\text{Li}^*(3.56) [0^+; T = 1]$ see (1983RO12, 1984BU01, 1986BU07).

1. (a) ${}^3\text{He}({}^3\text{H}, \gamma){}^6\text{Li}$	$Q_m = 15.7955$	
(b) ${}^3\text{He}({}^3\text{H}, n){}^5\text{Li}$	$Q_m = 10.13$	$E_b = 15.7955$
(c) ${}^3\text{He}({}^3\text{H}, d){}^4\text{He}$	$Q_m = 14.32049$	
(d) ${}^3\text{He}({}^3\text{H}, {}^3\text{H}){}^3\text{He}$		

Capture γ -rays (reaction (a)) to the first three states of ${}^6\text{Li}$ [$\gamma_0, \gamma_1, \gamma_2$] have been observed for $E({}^3\text{He}) = 0.5$ to 25.8 MeV , while the yields of γ_3 and γ_4 have been measured for $E({}^3\text{He}) = 12.6$ to 25.8 MeV . The γ_2 excitation function does not show resonance structure. However, the $\gamma_0, \gamma_1, \gamma_3$ and γ_4 yields do show broad maxima at $E({}^3\text{He}) = 5.0 \pm 0.4$ [γ_0, γ_1], 20.6 ± 0.4 [γ_1], ≈ 21 [γ_3] and 21.8 ± 0.8 [γ_4] MeV . The magnitude of the ground-state-capture cross section is well accounted for by a direct-capture model; that for the γ_1 capture indicates a non-direct contribution above $E({}^3\text{He}) = 10 \text{ MeV}$, interpreted as a resonance due to a state with $E_x = 25 \pm 1 \text{ MeV}$, $\Gamma_{\text{cm}} = 4 \text{ MeV}$, $T = 1$ (because the transition is E1, to a $T = 0$ final state) [the E1 radiative width $|M|^2 \geq 5.2/(2J + 1) \text{ W.u.}$], $J^\pi = (2, 3, 4)^-, \alpha + p + n$ parentage. The γ_4 resonance is interpreted as being due to a broad state at $E_x = 26.6 \text{ MeV}$ with $T = 0$. $J^\pi = 3^-$ is consistent with the measured angular distribution. The ground and first excited state reduced widths for ${}^3\text{He} + t$ parentage, $\theta_0^2 = 0.8 \pm 0.2$ and $\theta_1^2 = 0.6 \pm 0.3$: see (1974AJ01). See also (1985MOZZ, 1986MOZQ, 1987MO1I; theor.).

The angular distribution and polarization of the neutrons in reaction (b) have been measured at $E({}^3\text{He}) = 2.70$ and 3.55 MeV . The excitation function for $E({}^3\text{He}) = 0.7$ to 3.8 MeV decreases monotonically with energy. The excitation function for n_0 has been measured for $E({}^3\text{He}) = 2$ to 6 MeV and for $E({}^3\text{He}) = 14$ to 26 MeV ; evidence for a broad structure at $E({}^3\text{He}) = 20.5 \pm 0.8 \text{ MeV}$ is reported [${}^6\text{Li}^*(26.1)$]: see (1979AJ01).

Angular distributions of deuterons (reaction (c)) have been measured for $E_t = 1.04$ to 3.27 MeV and at $E({}^3\text{He}) = 0.29$ to 32 MeV . Polarization measurements are reported for $E_t = 9.02$ to 17.27 MeV [see (1979AJ01)], as well as at $E({}^3\text{He}) = 18.0$ and 33.0 MeV (1986RA1C). See also (1986KO1K) and (1985CA41).

Elastic scattering (reaction (d)) angular distributions have been measured at $E({}^3\text{He}) = 5.00$ to 32.3 MeV and excitation functions have been reported for $E({}^3\text{He}) = 4.3$ to 33.4 MeV : see (1979AJ01). At the lower energies the elastic yield is structureless and decreases monotonically with energy. Polarization measurements are reported for $E_t = 9.02$ to 33.3 MeV . A strong change

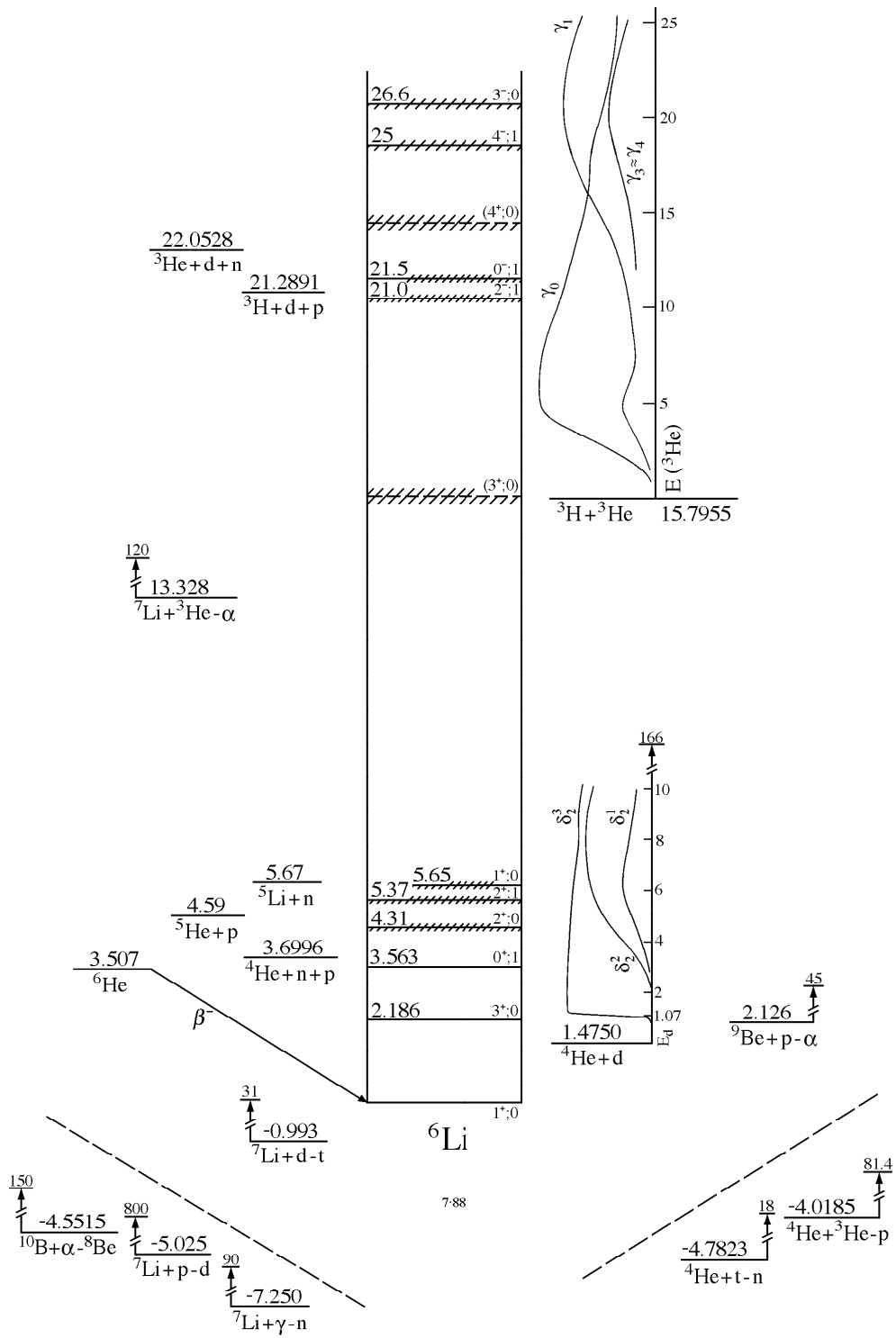

Fig. 2: Energy levels of ${}^6\text{Li}$. For notation see Fig. 1.

occurs in the analyzing power angular distributions at $E_t = 15$ MeV. A phase-shift analysis [single level R -matrix formalism, $L \leq 4$] yields P-states [$0^-, 2^-; T = 1$] at $E_x \approx 21.5$ and 21.0 MeV and F-states [$3^-, 4^-; T = 1$] at $E_x \approx 26.7$ and 25.7 MeV. There is some indication also of $T = 0, 3^-, 5^-$ and 3^+ states at $E_x \approx 25, 29.5$ and 31.5 MeV whose decay is presumably primarily by $d + \alpha$: see (1979AJ01).

For other channels see (1984AJ01). See also (1984KR1B; theor.).

$$2. \ ^3\text{H}(\alpha, n)^6\text{Li} \quad Q_m = -4.7823$$

$^6\text{Li}^*(0, 2.19)$ have been populated: see (1974AJ01). See also ^7Li , (1983CO1E) and (1983FU11; theor.).

$$3. \ ^3\text{He}(^3\text{He}, \pi^+)^6\text{Li} \quad Q_m = -123.792$$

Differential cross sections are reported for the transitions to $^6\text{Li}^*(0, 2.19)$ for $E(^3\text{He}) = 350, 420, 500$ and 600 MeV (1983LE26). See also (1984AJ01), (1983BR31, 1983JA13) and (1984GE05; theor.).

$$4. \ ^4\text{He}(d, \gamma)^6\text{Li} \quad Q_m = 1.4750$$

No resonance has been observed corresponding to formation of $^6\text{Li}^*(3.56)$ [$0^+; T = 1$]: the parity-forbidden $\Gamma_\alpha \leq 6 \times 10^{-7}$ eV (1984RO04). See also Table 6.2.

The cross section for the capture cross section has been measured for $E_\alpha = 3$ to 25 MeV by detecting the recoiling ^6Li ions: the direct capture is overwhelmingly E2 with a small E1 contribution. The spectroscopic overlap between the $^6\text{Li}_{\text{g.s.}}$ and $\alpha + d$ is 0.85 ± 0.04 : see (1984AJ01). See also (1982KI11), (1985CA41, 1986LA22, 1986LA27) and (1984AK01, 1985AK1B, 1986AK1C, 1986BA1R; theor.).

$$5. \text{ (a) } ^4\text{He}(d, np)^4\text{He} \quad Q_m = -2.22459 \quad E_b = 1.4750$$

$$\text{ (b) } ^4\text{He}(d, t)^3\text{He} \quad Q_m = -14.32049$$

Reaction (a) has been studied to $E_\alpha = 165$ MeV and to $E_d = 21.0$ MeV: see (1979AJ01, 1984AJ01). Recent measurements are reported at $E_d = 5.4, 6.0$ and 6.8 MeV (1985LU08; VAP, TAP), 6 to 11 MeV (1985OS02; VAP), 10.05 MeV (1983BR23; VAP, TAP) and 12.0 and 21.0 MeV (1983IS10; VAP, TAP) and at $E_\alpha = 11.3$ MeV (1987BR07). It is clear that Coulomb effects need to be taken into account to understand the data. See also (1986DO1K).

(1986BR1N, 1986VUZZ, 1986VU1B, 1987VU1A; prelim.) have measured VAP and TAP at $E_{\bar{d}} = 35$ and 45 MeV in reaction (b). See also (1987GAZZ). For the earlier work, and for the other breakup channels, see (1974AJ01, 1979AJ01, 1984AJ01). See also (1988PUZZ) and (1983BA42, 1985DO03, 1986KO1J, 1987KA1M, 1987KUZI, 1987MI06, 1988KA1J, theor.).

6. ${}^4\text{He}(d, d){}^4\text{He}$

$$E_b = 1.4750$$

Elastic differential cross-section and polarization measurements have been carried out up to $E_{\alpha} = 166$ MeV and $E_d = 45$ MeV: see (1974AJ01, 1979AJ01, 1984AJ01). Recent measurements are reported at $E_d = 0.87$ to 1.43 MeV (1984BA19, 1985BAYZ; prelim.), at $E_{\bar{d}} = 11.9$ MeV (1988EL01; TAP), 21 MeV (see 1986MI1E; VAP, TAP), 24.0 and 38.2 MeV (1986GR1D; TAP; prelim.), 31.8 to 39.0 MeV (1986KO1M; TAP; prelim.), 56 MeV (1985NI01; VAP, TAP) and at $E_{\alpha} = 7.0$ GeV/c (1984SA39). For a study of the inclusive inelastic scattering at $E_{\alpha} = 7.0$ GeV/c see (1987BA13).

Phase-shift analyses, particularly that by (1983JE03) which uses all available differential cross section, vector and tensor analyzing power measurements and $L \leq 5$, in the range $E_d = 3$ to 43 MeV lead to the results displayed in Table 6.3. It is found that the d-wave shifts are split and exhibit resonances at $E_x = 2.19$ (3D_3), 4.7 (3D_2) and 5.65 MeV (3D_1). (1983JE03) suggest very broad G_3 and G_4 resonances at $E_d = (19.3)$ and 33 MeV, a D_3 resonance at 22 MeV and F_3 and F_2 resonances at ≈ 34 and ≈ 39 MeV, corresponding to states which are primarily of $(d + \alpha)$ parentage.

(1985JE04) have investigated the points where $A_{yy} = 1$ and report four such points at $E_d = 4.30$ [$\theta_{\text{cm}} = 120.7^\circ$], 4.57 (58.0°), 11.88 (55.1°) and 36.0 ± 1.0 MeV ($150.1 \pm 0.3^\circ$). [For the latter see also (1986KO1M)]. The correspondence of these polarization maxima to ${}^6\text{Li}$ states is discussed by (1985JE04). For a discussion of the M -matrix see (1988EL01). For recent work on $(\alpha + d)$ correlations involving ${}^6\text{Li}^*(0, 2.19, 4.31 + 5.65)$ see (1987CH08, 1987CH33, 1987PO03) and (1987FO08).

See also (1984AJ01, 1984PL1A, 1987GR08) and (1983HAYX, 1983SA39, 1983SU1B, 1984KA1E, 1984LO1C, 1984SC1A, 1984WA1H, 1985FI01, 1985FR1F, 1985HA04, 1985KA20, 1985LI1F, 1985MI1F, 1985SA1B, 1985ZH1A, 1986BO01, 1986FI07, 1986FR12, 1986KO1J, 1986MI1D, 1986MI1E, 1986SA1D, 1987HA34, 1987KU1G, 1987LE1C, 1987MI06, 1987PR08, 1987SA1C, 1988BR1E, 1988BU1G, 1988KA1J, 1988VA18; theor.).

7. (a) ${}^4\text{He}({}^3\text{He}, p){}^6\text{Li}$ $Q_m = -4.0185$

(b) ${}^4\text{He}({}^3\text{He}, pd){}^4\text{He}$ $Q_m = -5.49354$

Angular distributions have been measured at $E({}^3\text{He}) = 8$ to 18 MeV and $E_{\alpha} = 42, 71.7$ and 81.4 MeV: see (1974AJ01). At $E_{\alpha} = 28, 63.7, 71.7$ and 81.4 MeV the α -spectra show that the sequential decay (reaction (b)) involves ${}^6\text{Li}^*(2.19)$ and possibly ${}^5\text{Li}$: see (1979AJ01).

Table 6.3: Levels of ${}^6\text{Li}$ from ${}^4\text{He}(d, d){}^4\text{He}$ ^a

E_d (MeV)	$J^\pi; T$	E_x (MeV)	$\Gamma_{\text{c.m.}}$ (MeV)	Γ_d/Γ ^b	γ_d^2 ^c
1.070 ± 0.003	$3^+; 0$	2.187			0.27
4.34 ± 0.04	$2^+; 0$	4.36	1.32 ± 0.04	0.967	0.511
5.7 ± 0.1 ^d	$1^+; 0$	5.3	1.9 ± 0.1	0.74	0.34
(19.3 ± 1.3)	$3^+; 0$	(14.3)	26.7 ± 1.0	0.34	1.69
(21.6 ± 1.1)	$3^+; 0$	(15.8)	17.8 ± 0.8	0.76	0.77
33 ± 2	4^+	23	12 ± 2	0.15	0.14
34 ± 5	3^-	24	16 ± 3	0.30	0.24
39_{-9}^{+3}	2^-	27	22 ± 7	0.43	0.42

^a The data in this table are mostly from the S -matrix analysis of (1983JE03). The results are unique up to $E_d = 15$ MeV. See also Table 6.4 in (1974AJ01), and Tables 6.3 in (1979AJ01) and (1984AJ01).

^b The errors in Γ_d/Γ are typically 0.03.

^c In units of the Wigner limit $\gamma_w^2 = 2.93$ MeV for a radius of 4.0 fm. I am indebted to W. Gruebler for pointing out an error to me.

^d 6.26 MeV (R -matrix analysis); $E_x = 5.65$ MeV.

8. (a) ${}^4\text{He}(\alpha, d){}^6\text{Li}$ $Q_m = -22.3717$
 (b) ${}^4\text{He}(\alpha, pn){}^6\text{Li}$ $Q_m = -24.5963$
 (c) ${}^4\text{He}(\alpha, \alpha d){}^2\text{H}$ $Q_m = -23.84674$

Reactions (a) and (b) have been studied to $E_\alpha = 158.2$ MeV [see (1979AJ01, 1984AJ01)] and at 198.4 MeV (1985WO11). The dependence of the cross section on energy shows that the $\alpha + \alpha$ process does not contribute significantly to ${}^6\text{Li}$ (and ${}^7\text{Li}$) synthesis above $E_\alpha = 250$ MeV (1985WO11) [and see for additional comments on astrophysical problems]. For reaction (c) [and excited states of ${}^4\text{He}$] see (1984AJ01): ${}^6\text{Li}^*(2.19)$ is involved in the process.

9. ${}^6\text{He}(\beta^-){}^6\text{Li}$ $Q_m = 3.507$

See ${}^6\text{He}$, reaction 1.

10. (a) ${}^6\text{Li}(\gamma, n){}^5\text{Li}$ $Q_m = -5.67$
 (b) ${}^6\text{Li}(\gamma, p){}^5\text{He}$ $Q_m = -4.59$

(c) ${}^6\text{Li}(\gamma, d){}^4\text{He}$	$Q_m = -1.4750$
(d) ${}^6\text{Li}(\gamma, t){}^3\text{He}$	$Q_m = -15.7955$

The (γ, n) and (γ, Xn) cross sections increase from threshold to a maximum at $E_\gamma \approx 12$ MeV then decrease to $E_\gamma = 32$ MeV: see (1984AJ01) and (1988DI02). (1984DY01) also report a broad peak at 16 MeV. The cross section for photoproton production (reaction (b)) is generally flat up to 90 MeV. [The previously reported hump at $E_\gamma \approx 16$ MeV is almost certainly due to oxygen contamination: see (1984AJ01).] See also (1988CA11) and ${}^5\text{He}$. The cross section for reaction (c) is $\leq 5 \mu\text{b}$ in the range $E_\gamma = 2.6$ to 17 MeV consistent with the expected inhibition of dipole absorption by isospin selection rules: see (1966LA04). The onset of quasideuteron photodisintegration between 25 and 65 MeV is suggested by the study of (1984WA18; $E_{\text{bs}} = 67$ MeV). The 90° differential cross section for reaction (d) decreases monotonically for $E_\gamma = 18$ to 70 MeV: reaction (d) contributes $\approx \frac{1}{3}$ of the total cross section for ${}^6\text{Li} + \gamma$, consistent with a ${}^3\text{H} + {}^3\text{He}$ cluster description of ${}^6\text{Li}_{\text{g.s.}}$ with $\theta^2 \approx 0.68$. The agreement with the inverse reaction, ${}^3\text{H}({}^3\text{He}, \gamma)$ [see reaction 1] is good: see (1984AJ01). See also (1986LI1F).

The absorption cross section has been studied in the range $E_\gamma \approx 100$ to 340 MeV; it shows a broad bump centered at ≈ 125 MeV and a fairly smooth increase to a maximum at ≈ 320 MeV: see (1984AJ01). For spallation studies see (1974AJ01, 1984AJ01). For pion production see (1986GL07, 1987GL01) and (1984AJ01). See also (1987GA22, 1987LI32, 1987PI06) and (1983BU1A, 1984BU1C, 1984IR1A, 1985LO02, 1985KO22, 1985VA1C, 1986AH03, 1986AK1B, 1986AV06, 1987BA2C, 1987BU04, 1987DU09, 1987LU1B, 1988BU1D; theor.).

11. ${}^6\text{Li}(\gamma, \gamma){}^6\text{Li}$

The width, Γ_γ , of ${}^6\text{Li}^*(3.56) = 8.1 \pm 0.5$ eV: see (1974AJ01) and Table 6.4 in (1979AJ01); $E_x = 3562.88 \pm 0.10$ keV: see (1984AJ01). See also (1987PI06).

12. (a) ${}^6\text{Li}(e, e){}^6\text{Li}$

(b) ${}^6\text{Li}(e, \text{ep}){}^5\text{He}$	$Q_m = -4.59$
(c) ${}^6\text{Li}(e, \text{ed}){}^4\text{He}$	$Q_m = -1.4750$

The elastic scattering has been studied for $E_e = 85$ to 600 MeV: see (1974AJ01, 1979AJ01, 1984AJ01). The results appear to require that the ground state be viewed as an α -d cluster in which the deuteron cluster is deformed and aligned. The ground-state M1 current density has also been calculated (1982BE11). A model-independent analysis of the elastic scattering yields $r_{\text{rms}} = 2.51 \pm 0.10$ fm. See also the discussion in (1984DO20).

Table 6.4 here and Table 6.4 in (1984AJ01) summarize the results obtained in the inelastic scattering of electrons. Form factors have been measured for ${}^6\text{Li}^*(2.19, 3.56, 5.37)$ as well as for

Table 6.4: Levels of ${}^6\text{Li}$ from ${}^6\text{Li}(e, e')$ and ${}^6\text{Li}(\gamma, \gamma')$ ^a

E_x (MeV)	$J^\pi; T$	Γ_{γ_0} (eV)	Multipolarity
2.183 ± 0.009 ^b	$3^+; 0$	$(4.40 \pm 0.34) \times 10^{-4}$	E2
3.563 ± 0.010	$0^+; 1$	8.19 ± 0.17 ^c	M1
4.27 ± 0.04	$2^+; 0$	$(5.4 \pm 2.8) \times 10^{-3}$	E2
5.379 ± 17 ^{c, d}	$2^+; 1$	0.27 ± 0.05	M1

^a See Tables 6.4 in (1979AJ01, 1984AJ01) for references and for the earlier work.

^b $B(\text{E}2)^\dagger = 21.8 \pm 4.8 e^2 \cdot \text{fm}^4$.

^c Weighted mean of values shown in Table 6.4 in (1979AJ01).

^d $\Gamma = 540 \pm 20$ keV.

the $t + {}^3\text{He}$ continuum up to 4 MeV above threshold [no narrow structures corresponding to ${}^6\text{Li}$ states are observed]: see (1984AJ01).

For reaction (b) see ${}^5\text{He}$ and (1987VA08) and (1987VA1N). Angular distributions for the d_0 group in the (e, d_0) reaction have been measured for $E_x = 10$ to 28 MeV. The deduced E1 and E2 components of the (γ, d_0) cross section show no structure. The E1 strength implies non-negligible isospin mixing in this energy region (1986TA06). At $E_e = 480$ MeV (reaction (c)) the α -d momentum distribution in the ground state of ${}^6\text{Li}$ has been studied. The results are well accounted for by an α NN model. The α -d probability in the ground state of ${}^6\text{Li}$ is 0.73 [estimated ± 0.1]. The data are consistent with the expected $2S$ character of the α -d relative wave function (1986EN05). See also (1986EV1A). π^0 production involving ${}^6\text{Li}^*(2.19, 3.56, 5.37)$ is reported at $E_e = 500$ MeV (1987NA1I; prelim.).

For the earlier work see (1979AJ01, 1984AJ01). See also (1986BA85), (1986PE05, 1987DE43) and (1983RE15, 1983SA39, 1984CH20, 1984CO08, 1984KO16, 1984KR10, 1984KU03, 1984PA08, 1984YP01, 1984ZH1A, 1985CH01, 1985ER06, 1985KH07, 1985LO1A, 1986AK1A, 1986AZ01, 1986BE1L, 1986CHZX, 1986DO11, 1986KE1F, 1986KR12, 1986KR1E, 1986RE1D, 1986SA1D, 1987KR07, 1987LE1C, 1987LO16, 1987SA1C, 1988CH1D, 1988KU1C; theor.).

13. (a) ${}^6\text{Li}(\pi^\pm, \pi^\pm){}^6\text{Li}$

(b) ${}^6\text{Li}(\pi^+, \pi^+p){}^5\text{He}$ $Q_m = -4.59$

(c) ${}^6\text{Li}(\pi^+, {}^3\text{He}){}^3\text{He}$ $Q_m = 123.792$

(d) ${}^6\text{Li}(\pi^+, \pi^+d){}^4\text{He}$ $Q_m = -1.4750$

Elastic angular distributions have been measured at $E_{\pi^+} \approx 50$ MeV [see (1984AJ01)] and at $E_{\pi^\pm} = 100, 180$ and 240 MeV (1986AN04; also to ${}^6\text{Li}^*(2.19)$). Differential cross sections are also reported for $E_{\pi^+} = 100$ to 260 MeV to ${}^6\text{Li}^*(0, 2.19, 3.56, 4.25)$. The excitation function

for the unnatural-parity transition to ${}^6\text{Li}^*(3.56)$ has an anomalous energy dependence (1984KI16). For reaction (b) see (1987HU02) and for reaction (c) see (1983BA26, 1983LO10, 1985MC05, 1986MC11). For a study of reaction (d) at $E_{\pi^+} = 130$ MeV see (1987HU13). For the $(\pi^+, 2p)$ reaction at $E_{\pi^+} = 59.4$ MeV to states in ${}^4\text{He}$ see (1986RI01). See also p. 32.

14. (a) ${}^6\text{Li}(n, n){}^6\text{Li}$

(b) ${}^6\text{Li}(n, nd){}^4\text{He}$ $Q_m = -1.4750$

Angular distributions involving the groups to ${}^6\text{Li}^*(0, 2.19)$ have been reported at $E_n = 1.0$ to 14.6 MeV [see (1984AJ01)] and at 4.2, 5.4 and 14.2 MeV (1985CH37; n_0, n_1), 7.5 to 14 MeV (1983DA22; n_0), 8.9 MeV (1984FE1A; n_0), 8.0 and 24 MeV (1986HAZR; n_0, n_1) and at $E_n = 5$ to 17 MeV (1986PF1A; prelim.; n_0). For reaction (b) see (1985CH37, 1984AJ01). See also ${}^7\text{Li}$, (1987SC08) and (1984UD1A, 1985HO1E, 1985LI1F, 1986BE1L; theor.).

15. (a) ${}^6\text{Li}(p, p){}^6\text{Li}$

(b) ${}^6\text{Li}(p, 2p){}^5\text{He}$ $Q_m = -4.59$

(c) ${}^6\text{Li}(p, pd){}^4\text{He}$ $Q_m = -1.4750$

(d) ${}^6\text{Li}(p, p^3\text{H}){}^3\text{He}$ $Q_m = -15.7955$

(e) ${}^6\text{Li}(p, pn){}^5\text{Li}$ $Q_m = -5.67$

Proton angular distributions have been measured for $E_p = 0.5$ to 800 MeV [p_0, p_1, p_2, p_3] [see (1966LA04, 1974AJ01, 1984AJ01)] and at $E_p = 5$ to 17 MeV (1986PF1A; prelim.; p_0). Double-differential cross sections for the continuum yield [$E_x = 1.5$ – 3.5 MeV] are reported at $E_p = 65$ MeV (1987TO06; prelim.). See also (1983GLZZ, 1983PO1B, 1983POZX). For a summary of the results on excited states see Table 6.5.

Reaction (b) has recently been studied at 70 MeV (1983GO06), at 50–100 MeV (1984PA1B, 1985PA1B; prelim.) and 1 GeV (1985BE30): see ${}^5\text{He}$ and (1984AJ01) for the earlier work. Reaction (c) has been studied at $E_p = 9$ MeV to 1 GeV [see (1974AJ01, 1979AJ01, 1984AJ01)] and at 20 and 42 MeV (1983CA13) [report involvement of ${}^6\text{Li}^*(4.31, 5.65)$], at 70 MeV (1983GO06, 1985PAZL, 1985PA04) and at 119.6 and 200.2 MeV (1984WA09, 1985WA25). In the latter experiments the spectroscopic factors for ${}^6\text{Li}_{g.s.}$ are deduced to be 0.76 [at 119.6 MeV] and 0.84 [at 200.2 MeV] using DWIA and a bound-state Woods-Saxon $2S$ wave function (1984WA09, 1985WA25).

Work on reaction (d) has suggested that the ${}^3\text{He}+t$ parentage of ${}^6\text{Li}$ is comparable with the $\alpha+d$ parentage: see (1984AJ01). See also (1985PAZL). For reaction (e) see ${}^5\text{Li}$, ${}^6\text{Be}$ and (1985BE30). The $(p, 3p)$ reaction has been studied by (1984NA17). For antiproton studies see (1987AS06) and p. 32. See also (1984AJ01) for the earlier work and ${}^7\text{Be}$, (1983AN18, 1986SA1Q, 1987GAZM, 1987SA46, 1988MIZX), (1984LA33, 1985AL16, 1986CH1J, 1986WA11, 1987LE33) and (1982CH28,

Table 6.5: Parameters of levels of ${}^6\text{Li}$ ^a

E_x (MeV \pm keV)	$\Gamma_{\text{c.m.}}$ (keV)	Reactions
2.185 \pm 3	20.0 \pm 2.8	${}^4\text{He}(d, d){}^4\text{He}$
2.187 \pm 3		${}^4\text{He}(d, d){}^4\text{He}$
2.188 \pm 6	24 \pm 2 ^c	${}^6\text{Li}(p, p'), (d, d'), {}^7\text{Li}(d, t){}^6\text{Li}$
2.203 \pm 6		${}^9\text{Be}(p, \alpha){}^6\text{Li}$
2.186 \pm 2	24 \pm 2	“best” values
3.56288 \pm 0.10	(8.2 \pm 0.2) $\times 10^{-3}$	Table 6.4
4.34 \pm 40		${}^4\text{He}(d, d){}^6\text{Li}$
4.27 \pm 40		${}^6\text{Li}(e, e'){}^6\text{Li}$
4.40 \pm 120	1490 \pm 150	${}^6\text{Li}(p, p'){}^6\text{Li}$
4.32 \pm 40	1820 \pm 110	${}^6\text{Li}(d, d'){}^6\text{Li}$
4.3 \pm 100	600 \pm 100	${}^7\text{Li}({}^3\text{He}, \alpha){}^6\text{Li}$
4.3 \pm 200	1600 \pm 300	${}^7\text{Li}({}^3\text{He}, \alpha d){}^4\text{He}$
4.30 \pm 10	850 \pm 50, 480 \pm 80	${}^9\text{Be}(p, \alpha){}^6\text{Li}$
4.312 \pm 22	1700 \pm 100	“best” values
5.379 \pm 17 ^d	540 \pm 20 ^d	${}^6\text{Li}(e, e'){}^6\text{Li}$
5.33 \pm 80	560 ⁺³⁴⁰ ₋₁₀₀	${}^6\text{Li}(p, p'){}^6\text{Li}$
5.34 \pm 20	560 \pm 40 ^b	${}^7\text{Li}({}^3\text{He}, \alpha){}^6\text{Li}$
5.325 \pm 5	270 \pm 12	${}^9\text{Be}(p, \alpha){}^6\text{Li}$
5.366 \pm 15	540 \pm 20	“best” values
5.65 \pm 50 ^e		${}^4\text{He}(d, d){}^4\text{He}$
5.7	1000 ⁺⁶⁰⁰ ₋₄₀₀ ^b	${}^6\text{Li}(p, p'){}^6\text{Li}$
5.65 \pm 200	1650 \pm 300	${}^7\text{Li}({}^3\text{He}, \alpha d){}^4\text{He}$
5.65 \pm 40	900 \pm 60, 1260 \pm 120	${}^9\text{Be}(p, \alpha){}^6\text{Li}$
5.65 \pm 50	1500 \pm 200	“best” values

^a For references and other values see Tables 6.5 in (1979AJ01, 1984AJ01).

^b See references (c) and (d) in Table 6.5 in (1979AJ01).

^c And C.P. Browne, private communication.

^d See Table 6.4 in (1979AJ01).

^e See Table 6.3 in (1979AJ01).

1983GO17, 1983KA1A, 1983SM04, 1984GU14, 1984KO1E, 1984KU03, 1984KU06, 1984MU01, 1985BE60, 1985DO16, 1985KA1D, 1985PA03, 1986CHZX, 1986IM1A, 1986IM01, 1986OS08, 1986VL1A, 1986ZH03, 1987FA1H, 1987HA01, 1987IM1F, 1987IM04, 1987VD01, 1987ZH1D, 1988CH06, 1988VD1A; theor.).

16. (a) ${}^6\text{Li}(d, d){}^6\text{Li}$
 (b) ${}^6\text{Li}(d, pn){}^6\text{Li}$ $Q_m = -2.22459$
 (c) ${}^6\text{Li}(d, 2d){}^4\text{He}$ $Q_m = -1.4750$
 (d) ${}^6\text{Li}(d, \alpha p){}^3\text{H}$ $Q_m = 2.5577$

Angular distributions of deuterons have been measured at $E_d = 4.5$ to 19.6 MeV [see (1979AJ01)] and at 50 MeV (1988KO1C; prelim.). The $T = 1, 0^+$ state, ${}^6\text{Li}^*(3.56)$ is not appreciably populated. For a summary of the results on excited states see Table 6.5.

At $E_d = 21$ MeV reaction (b) shows spectral peaking (characteristic of 1S_0 for the pn system [$T = 1$]) when ${}^6\text{Li}^*(3.56)$ is formed, in contrast with the much broader shape (characteristic of 3S_1) seen when ${}^6\text{Li}^*(0, 2.19)$ are populated. A study of reaction (c) at $E_d = 52$ MeV shows that the α -clustering probability, $N_{\text{eff}} = 0.12_{-0.06}^{+0.12}$ if a Hankel function is used. The α -particle and the deuteron clusters in ${}^6\text{Li}$ have essentially a relative orbital momentum of $l = 0$. The D-state probability of the ground state of ${}^6\text{Li}$ is $\approx 5\%$ of the S-state. Quasi-free scattering is an important process even for $E_d = 6$ to 11 MeV. Interference effects are evident in reaction (c) proceeding through ${}^6\text{Li}^*(2.19, 4.31)$: this is due to the experiment being unable to determine whether the detected particle was emitted first or second in the sequential decay. Reactions (c) and (d) studied at $E_d = 7.5$ to 10.5 MeV indicate that the three-body breakup of ${}^6\text{Li}$ at these low energies is dominated by sequential decay processes. See (1979AJ01) for references.

See also ${}^8\text{Be}$, (1987AL23) and (1982CH28, 1983GO24, 1983LY04, 1984BL21, 1984KU15, 1985LI1C, 1986AV01; theor.).

17. ${}^6\text{Li}(t, t){}^6\text{Li}$

At $E_t = 17$ MeV angular distributions have been measured for the tritons to ${}^6\text{Li}^*(0, 3.56)$: see (1979AJ01).

18. (a) ${}^6\text{Li}({}^3\text{He}, {}^3\text{He}){}^6\text{Li}$
 (b) ${}^6\text{Li}({}^3\text{He}, p\alpha){}^4\text{He}$ $Q_m = 16.8782$

Angular distributions have been measured at $E({}^3\text{He}) = 8$ to 217 MeV [see (1979AJ01, 1984AJ01)] and at $34, 50, 60$ and 72 MeV (1986BR31; elastic). For reaction (b) see ${}^5\text{Li}$ (1984AR17, 1987ZA07). See also ${}^9\text{B}$.

19. (a) ${}^6\text{Li}(\alpha, \alpha){}^6\text{Li}$
 (b) ${}^6\text{Li}(\alpha, 2\alpha){}^2\text{H}$ $Q_m = -1.4750$

Angular distributions (reaction (a)) have been measured at $E_\alpha = 1.39$ to 166 MeV [see (1974AJ01, 1979AJ01, 1984AJ01)] and at $E_\alpha = 36.6$ and 50.5 MeV (1986BR31). See also (1987BU27, 1986ROZK). See also ¹⁰B.

Reaction (b) has been studied at $E_\alpha = 6.6$ to 700 MeV: see (1974AJ01, 1979AJ01, 1984AJ01). At the latter energy and using a width parameter of 60.6 MeV/c the effective number of $\alpha + d$ clusters for ${}^6\text{Li}_{\text{g.s.}}$, $n_{\text{eff}} = 0.98 \pm 0.05$. The results are very model dependent: see (1984AJ01). At $E_\alpha = 27.2$ MeV ${}^6\text{Li}^*(2.19)$ is very strongly populated (1985KO29). See also (1982CH28, 1983AV02, 1983BE51, 1983BU15, 1985BE60, 1986GA1F, 1986ZE01, 1987KO1L, 1988LE06; theor.).

20. (a) ${}^6\text{Li}({}^6\text{Li}, {}^6\text{Li}){}^6\text{Li}$
 (b) ${}^6\text{Li}({}^6\text{Li}, 2d)2 {}^4\text{He}$ $Q_m = -2.9501$
 (c) ${}^6\text{Li}({}^6\text{Li}, \alpha)2 {}^4\text{He}$ $Q_m = 20.897$

Angular distributions of ${}^6\text{Li}$ ions have been studied for $E({}^6\text{Li}) = 3.2$ to 36 MeV [see (1974AJ01, 1979AJ01, 1984AJ01)] and at $E({}^6\text{Li}) = 2.0$ to 5.5 MeV (1983NO08) and 156 MeV (1985SA36; ${}^6\text{Li}^*(0, 2.19)$), (1985MI05; elastic; ${}^6\text{Li}^*(2.19, 3.56)$ are also populated), (1987EY01; several states in ${}^{12}\text{C}$). Reaction (b) has been studied for $E({}^6\text{Li}) = 36$ to 47 MeV: enhancements in yield, due to double spectator poles, have been observed in d-d and α - α but not in α -d double coincidence spectra. The widths of the peaks are smaller than those predicted from the momentum distribution of $\alpha + d$ clusters in ${}^6\text{Li}$. ${}^6\text{Li}^*(2.19)$ was also populated. See references in (1984AJ01). Recent work on reaction (b) is reported by (1984LA19: 2.4 and 4.2 MeV) and by (1985NO1A). For reaction (c) see (1987LA25). See also ${}^{12}\text{C}$ in (1985AJ01), (1983CH59) and (1984CH1E, 1986KA1B, 1986SA1D, 1987AR13, 1987SA1C; theor.).

21. ${}^6\text{Li}({}^7\text{Li}, {}^7\text{Li}){}^6\text{Li}$

Angular distributions have been measured at $E({}^7\text{Li}) = 78$ MeV to ${}^6\text{Li}^*(0, 2.19)$ (1986GLZU; prelim.).

22. ${}^6\text{Li}({}^9\text{Be}, {}^9\text{Be}){}^6\text{Li}$

The elastic scattering has been studied at $E({}^6\text{Li}) = 4.0, 6.0$ and 24 MeV [see (1979AJ01)], at 32 MeV (1985CO09) and at 50 MeV (1988TRZY; prelim.; also inelastic). For the interaction cross section at $E({}^6\text{Li}) = 790$ MeV/A see (1985TA18).

23. ${}^6\text{Li}({}^{10}\text{B}, {}^{10}\text{B}){}^6\text{Li}$

The elastic scattering has been studied at $E({}^6\text{Li}) = 5.8$ and 30 MeV: see (1979AJ01).

24. (a) ${}^6\text{Li}({}^{12}\text{C}, {}^{12}\text{C}){}^6\text{Li}$

(b) ${}^6\text{Li}({}^{13}\text{C}, {}^{13}\text{C}){}^6\text{Li}$

(c) ${}^6\text{Li}({}^{14}\text{C}, {}^{14}\text{C}){}^6\text{Li}$

The elastic scattering (reaction (a)) has been studied at $E({}^6\text{Li}) = 4.5$ to 156 MeV [see (1984AJ01)] and at $E({}^6\text{Li}) = 19.2$ MeV (1983RU09), 36 and 45 MeV [and $E({}^{12}\text{C}) = 72$ and 90 MeV] (1984VI02, 1985VI03; also to ${}^6\text{Li}^*(2.19, 4.31)$ and to various states of ${}^{12}\text{C}$), 90 MeV (1987DE02; also to various states of ${}^{12}\text{C}$), 123.5 and 168.6 MeV (1988KA09; and to various states of ${}^{12}\text{C}$), 150 MeV (1987TA21; also VAP), 156 MeV (1987EY01; and to various states in ${}^{12}\text{C}$) and at 210 MeV (1988NA02). See also (1986SHZP, 1987PA12). At $E({}^6\text{Li}) = 34$ MeV the d- α angular correlations involve ${}^6\text{Li}^*(0, 2.19)$ (1985CU04). See also ${}^{12}\text{C}$ in (1985AJ01, 1990AJ01). For pion production see (1984CH16). For the interaction cross section at $E({}^6\text{Li}) = 790$ MeV/A see (1985TA18). For VAP measurements at $E({}^6\text{Li}) = 30$ MeV see (1988VAZY).

The elastic scattering (reaction (b)) has been studied for $E({}^7\text{Li}) = 5.8$ to 40 MeV: see (1984AJ01). The elastic scattering (reaction (c)) has been measured for $E({}^6\text{Li}) = 93$ MeV (1987DE02). See also ${}^{18}\text{F}$ and ${}^{19}\text{F}$ in (1987AJ02), (1986MCZZ, 1988MCZY), (1983BI13, 1984HA53) and (1982GU21, 1983BU15, 1983DE48, 1983OS03, 1983SH24, 1984BR08, 1984GR05, 1984MU1D, 1984SA1B, 1985CO21, 1985SH1A, 1986BE45, 1986IO01, 1986KA1B, 1986MI24, 1986SA1D, 1986SAZJ, 1986SAZK, 1986SAZL, 1987AR13, 1987KA1I, 1987SA1C, 1987SA21, 1988DEZU, 1988DE1F, 1988SA15; theor.).

25. ${}^6\text{Li}({}^{16}\text{O}, {}^{16}\text{O}){}^6\text{Li}$

Elastic angular distributions have been reported at $E({}^6\text{Li}) = 4.5$ to 50.6 MeV [see (1984AJ01)], at $E({}^6\text{Li}) = 35.3$ and $E({}^{16}\text{O}) = 94.2$ MeV (1984VI02) and at 50 MeV (1988TRZY; prelim.; also inelastic). At $E({}^6\text{Li}) = 25.7$ and $E({}^{16}\text{O}) = 68.6$ MeV (1985VI03, 1984VI01) report some $\sigma(\theta)$ to ${}^6\text{Li}^*(2.19)$ [and to ${}^{16}\text{O}^*(6.13)$]. See (1985VI03, 1986SC28) for studies of the breakup. The VAP has been measured at $E({}^6\text{Li}) = 25.7$ MeV, and also using ${}^{16}\text{O}$ ions (1987VAZY; prelim.). For fusion cross sections see (1986MA19). See also ${}^{16}\text{O}$ in (1986AJ04), (1986MO1E, 1987PA12) and (1983BU15, 1983JO1A, 1984WI08, 1985CO21, 1985SA13, 1986SAZS; theor.).

26. (a) ${}^6\text{Li}({}^{24}\text{Mg}, {}^{24}\text{Mg}){}^6\text{Li}$

(b) ${}^6\text{Li}({}^{25}\text{Mg}, {}^{25}\text{Mg}){}^6\text{Li}$

(c) ${}^6\text{Li}({}^{26}\text{Mg}, {}^{26}\text{Mg}){}^6\text{Li}$

(d) ${}^6\text{Li}({}^{27}\text{Al}, {}^{27}\text{Al}){}^6\text{Li}$

The elastic scattering has been studied at $E(^6\text{Li}) = 88$ MeV, and at 36 MeV for reaction (c): see (1984AJ01). For the interaction cross section at $E(^6\text{Li}) = 790$ MeV/A (reaction (d)) see (1985TA18).

27. (a) $^6\text{Li}(^{28}\text{Si}, ^{28}\text{Si})^6\text{Li}$
 (b) $^6\text{Li}(^{30}\text{Si}, ^{30}\text{Si})^6\text{Li}$

The elastic scattering has been studied at $E(^6\text{Li}) = 13$ to 154 MeV [see (1984AJ01)], at 27 and 34 MeV (1983VI03) and at 210 MeV (1988NAZX). For a study of the decay see (1987NI04). See also (1984PU1A, 1985PU1B, 1986GR1A) and (1978GR22, 1982BR25, 1983DE48, 1983JO1A, 1983SA39, 1983SA1D, 1984BR1B, 1984BR28, 1984KI08, 1984WI08, 1985BR14, 1985SA1D, 1986BE45, 1986GR1G, 1986KA22, 1986SA1D, 1986SAZJ, 1986SAZK, 1986SAZL, 1987GR1N, 1987SA1C, 1987SA21; theor.). For reaction (b) see (1987AR13; theor.).

28. (a) $^6\text{Li}(^{39}\text{K}, ^{39}\text{K})^6\text{Li}$
 (b) $^6\text{Li}(^{40}\text{Ca}, ^{40}\text{Ca})^6\text{Li}$
 (c) $^6\text{Li}(^{44}\text{Ca}, ^{44}\text{Ca})^6\text{Li}$
 (d) $^6\text{Li}(^{48}\text{Ca}, ^{48}\text{Ca})^6\text{Li}$

Elastic scattering has been studied for $E(^6\text{Li}) = 26$ to 99 MeV: see (1984AJ01), and at $E(^6\text{Li}) = 34$ MeV (reaction (b)) by (1987VA31) and at 210 MeV (1988NAZX; reaction (b)). $^6\text{Li}^*(2.19)$ has been studied at $E(^{40}\text{Ca}) = 227$ MeV (1987VA31). For fusion measurements (reaction (b)) see (1984BR04). For breakup measurements (reaction (b)) see (1984GR20). See also (1986PL01) and (1983SA39, 1984GU09, 1985BL18, 1985SA1D, 1986GR1G, 1986SA1D, 1987SA21, 1986SAZJ, 1986SAZK, 1986SAZL; theor.).

29. (a) $^7\text{Li}(\gamma, n)^6\text{Li}$ $Q_m = -7.250$
 (b) $^7\text{Li}(\gamma, p\pi^-)^6\text{Li}$ $Q_m = -146.036$

Transitions to $^6\text{Li}^*(0, 2.19, 3.56)$ have been observed in reaction (a): see (1979AJ01, 1984AJ01). Differential cross sections are reported for $E_{\text{bs}} = 60$ to 120 MeV for the n_0+n_2 groups (1985SE17). Reaction (b) at 0.9 GeV involves $^6\text{Li}^*(2.19)$ (1985RE1A; prelim.). See also ^7Li , (1986GO1M) and (1985ST1A, 1986BA2G; theor.).

30. $^7\text{Li}(\pi^+, p)^6\text{Li}$ $Q_m = 133.101$

Differential cross sections have been measured at $E_{\pi^+} = 75$ and 175 MeV for the transitions to ${}^6\text{Li}^*(0, 2.19)$: see (1984AJ01).

31. (a) ${}^7\text{Li}(p, d){}^6\text{Li}$ $Q_m = -5.025$
 (b) ${}^7\text{Li}(p, pn){}^6\text{Li}$ $Q_m = -7.250$

Angular distributions of deuterons (reaction (a)) have been studied for $E_p = 167$ to 800 MeV [see (1979AJ01, 1984AJ01)] and at 18.6 MeV (1986GO23, 1987GO27; d_0, d_1, d_2 ; see for spectroscopic factors), 200 and 400 MeV (1985KR13; d_0, d_1, d_2 is weakly populated at 200 MeV) and at 800 MeV (1984SM04; d_0, d_1). The ratio of the intensities of the groups to ${}^6\text{Li}^*(2.19)$ and ${}^6\text{Li}_{g.s.}$ increases with energy. It is suggested that this can be understood in terms of a small admixture of 1f orbital in these states (1985KR13). A DWBA analysis of $E_p = 185$ MeV data leads to $C^2S = 0.87, 0.67, 0.24, (0.05), 0.14$, respectively for ${}^6\text{Li}^*(0, 2.19, 3.56, 4.31, 5.37)$. No other states were seen below $E_x \approx 20$ MeV: see (1979AJ01). In reaction (b) at $E_p = 1$ GeV the separation energy between ≈ 6.5 MeV broad $1p_{3/2}$ and $1s_{1/2}$ groups is reported to be 18.0 ± 0.8 MeV (1985BE30, 1985DO16). See also (1983LY04, 1988BE11, 1988GUZW; theor.).

32. ${}^7\text{Li}(d, t){}^6\text{Li}$ $Q_m = -0.993$

A study at $E_d = 23.6$ MeV of the relative cross sections of the analog reactions ${}^7\text{Li}(d, t){}^6\text{Li}$ (to the first two $T = 1$ states at 3.56 and 5.37 MeV) and ${}^7\text{Li}(d, {}^3\text{He}){}^6\text{He}$ (to the ground and 1.80 MeV excited states) shows that ${}^6\text{Li}^*(3.56, 5.37)$ have high isospin purity ($\alpha^2 < 0.008$): this is explained in terms of antisymmetrization effects which prevent mixing with nearby $T = 0$ states: see (1979AJ01). (1987BO39) [$E_d = 30.7$ MeV] deduce that the branching ratio of ${}^6\text{Li}^*(4.31) [2^+]$ into a dinucleon [$T = 1, S = 0$] is $(85 \pm 10)\%$: see also reactions 13 in ${}^6\text{He}$ and 4 in ${}^6\text{Be}$. See also (1987GUZZ; $E_d = 18$ MeV; angular distributions to ${}^6\text{Li}^*(0, 2.19, 3.56)$; prelim.) and (1984BL21, 1986AV01, 1988GUZW; theor.).

33. (a) ${}^7\text{Li}({}^3\text{He}, \alpha){}^6\text{Li}$ $Q_m = 13.328$
 (b) ${}^7\text{Li}({}^3\text{He}, d\alpha){}^4\text{He}$ $Q_m = 11.8527$

Angular distributions have been reported at $E({}^3\text{He}) = 5.1$ to 33.3 MeV [see (1974AJ01, 1984AJ01): the lower energy work has not been published]. Excited states observed in this reaction are displayed in Table 6.5. No other states are reported below $E_x = 10$ MeV: see (1979AJ01). (1986AN04) have analyzed unpublished data which suggest the involvement of several broad highly excited states of ${}^6\text{Li}$. See also (1987AL23).

Several attempts have been made to look at the isospin decay of ${}^6\text{Li}^*(5.37) [J^\pi; T = 2^+; 1]$ via ${}^7\text{Li}({}^3\text{He}, \alpha){}^6\text{Li}^* \rightarrow d + \alpha$: the branching is $< 1\%$. $\Gamma_p/\Gamma = 0.35 \pm 0.10$ and $\Gamma_{p+n}/\Gamma = 0.65 \pm 0.10$

for ${}^6\text{Li}^*(5.37)$: see (1979AJ01). ${}^4\text{He} + \text{d}$ spectra suggest the excitation of ${}^6\text{Li}^*(4.3)$ [$E_x = 4.3 \pm 0.2$ MeV, $\Gamma = 1.6 \pm 0.3$ MeV] and ${}^6\text{Li}^*(5.7)$ [$E_x = 5.65 \pm 0.2$ MeV, $\Gamma = 1.65 \pm 0.3$ MeV]: see (1984AJ01). See also (1985DA29). At $E({}^3\text{He}) = 120$ MeV the missing mass spectra for $({}^3\text{He}, 2\text{d})$ and $({}^3\text{He}, \text{pt})$ reflects the population of ${}^6\text{Li}^*(0, 2.19)$ and suggests broad structures at $E_x = 28.5$ and 32.9 MeV (1985FR01). See also ${}^{10}\text{B}$, (1988BO1J) and (1983KU17; theor.).

34. (a) ${}^7\text{Li}({}^6\text{Li}, {}^7\text{Li}){}^6\text{Li}$
 (b) ${}^7\text{Li}({}^7\text{Li}, {}^8\text{Li}){}^6\text{Li}$ $Q_m = -5.217$

At $E({}^6\text{Li}) = 93$ MeV a broad group ($\Gamma \approx 11$ MeV) centered at $E_x = 20$ MeV is reported in addition to other peaks at $E_x = 17.1 \pm 0.3$, 18.9 ± 0.3 and 21.2 ± 0.3 MeV (1987GLZW; prelim.). See (1984KO25) for reaction (b).

35. (a) ${}^9\text{Be}(\text{p}, \alpha){}^6\text{Li}$ $Q_m = 2.126$
 (b) ${}^9\text{Be}(\text{p}, 2\alpha){}^2\text{H}$ $Q_m = 0.651$
 (c) ${}^9\text{Be}(\text{p}, \text{pt}){}^6\text{Li}$ $Q_m = -17.688$

Angular distributions of α -particles (reaction (a)) have been measured at $E_p = 0.11$ to 45 MeV. [see (1974AJ01, 1979AJ01)] and at $E_p = 22.5$, 31 and 41 MeV (1986HA27; $\alpha_0, \alpha_1, \alpha_2$; see for spectroscopic factors). See also Table 6.5 and (1984AJ01). ${}^6\text{Li}^*(3.56)$ decays by γ -emission consistent with M1; $\Gamma_\alpha/\Gamma < 0.025$ [forbidden by spin and parity conservation]: see (1984AJ01). At $E_p = 9$ MeV the yield of reaction (b) is dominated by FSI through ${}^8\text{Be}^*(0, 2.9)$ and ${}^6\text{Li}^*(2.19)$ with little or no yield from direct three-body decay: see (1979AJ01). Reactions (b) and (c) at $E_p = 58$ MeV involve ${}^6\text{Li}^*(0, 2.19)$ (1985DE17). See also ${}^{10}\text{B}$, (1986AN26) and (1985MAZG, 1986KA26; theor.).

36. ${}^9\text{Be}(\text{d}, {}^5\text{He}){}^6\text{Li}$ $Q_m = -9.92$

See ${}^5\text{He}$.

37. ${}^9\text{Be}(\text{t}, {}^6\text{He}){}^6\text{Li}$ $Q_m = -5.381$

Angular distributions of ${}^6\text{He}_{\text{g.s.}} + {}^6\text{Li}_{\text{g.s.}}$ and ${}^6\text{He}_{\text{g.s.}} + {}^6\text{Li}_{3.56}^*$ [both listed ions were detected] have been measured at $E_t = 21.5$ and 23.5 MeV. In the latter case the final state is composed of two isobaric analog states: angular distributions are symmetric about 90° cm, within the overall

experimental errors. In the reaction leading to the ground states of ${}^6\text{He}$ and ${}^6\text{Li}$ differences from symmetry of as much as 40% are observed at forward angles. Angular distributions involving ${}^6\text{He}_{\text{g.s.}} + {}^6\text{Li}^*(2.19)$ and ${}^6\text{Li}_{\text{g.s.}} + {}^6\text{He}^*(1.8)$ have also been measured. This reaction appears to proceed predominantly by means of the direct pickup of a triton or ${}^3\text{He}$ from ${}^9\text{Be}$. Differential cross sections are also reported at $E_t = 17$ MeV: see (1984AJ01) for references.

$$38. {}^9\text{Be}({}^3\text{He}, {}^6\text{Li}){}^6\text{Li} \quad Q_m = -1.892$$

Angular distributions of ${}^6\text{Li}$ ions have been obtained at $E({}^3\text{He}) = 6$ to 10 MeV: see (1974AJ01). A study of the continuum suggests the population of ${}^6\text{Li}$ states at $E_x = 8-12, \approx 21$ and 21.5 MeV: see (1984AJ01).

$$39. {}^{10}\text{B}(n, {}^5\text{He}){}^6\text{Li} \quad Q_m = -5.35$$

Differential cross sections are reported at $E_n = 14.4$ MeV involving ${}^6\text{Li}^*(2.19)$ and ${}^5\text{He}_{\text{g.s.}}$ (1984TU02).

$$40. {}^{10}\text{B}(d, {}^6\text{Li}){}^6\text{Li} \quad Q_m = -2.985$$

Angular distributions involving ${}^6\text{Li}^*(0, 2.19)$ have been studied at $E_d = 13.6$ MeV (1983DO10) and at 19.5 MeV [see (1974AJ01)]. See also (1984SHZJ; theor.).

$$41. {}^{10}\text{B}({}^3\text{He}, {}^7\text{Be}){}^6\text{Li} \quad Q_m = -2.872$$

Angular distributions involving ${}^6\text{Li}^*(0, 2.19)$ have been measured at $E({}^3\text{He}) = 30$ MeV: see (1974AJ01).

$$42. {}^{10}\text{B}(\alpha, {}^8\text{Be}){}^6\text{Li} \quad Q_m = -4.5515$$

At $E_\alpha = 72.5$ MeV only ${}^6\text{Li}^*(0, 2.19)$ are observed: the latter is excited much more strongly than is the ground state [S_α for the ground state is 0.4 that for ${}^6\text{Li}^*(2.19)$]. The angular distributions for both transitions are flat: see (1979AJ01). See also (1984AJ01).

$$43. {}^{11}\text{B}(d, {}^7\text{Li}){}^6\text{Li} \quad Q_m = -7.189$$

See (1984AJ01).

$$44. \text{}^{11}\text{B}(\text{}^3\text{He}, \text{}^8\text{Be})\text{}^6\text{Li} \quad Q_m = 4.572$$

Angular distributions are reported at $E(\text{}^3\text{He}) = 71.8$ MeV involving several states in ${}^8\text{Be}$ (1986JA02, 1986JA14).

$$45. \text{}^{12}\text{C}(\text{p}, \text{}^7\text{Be})\text{}^6\text{Li} \quad Q_m = -22.566$$

Angular distributions involving ${}^7\text{Be}^*(0, 0.43)$ have been measured at $E_p = 40.3$ MeV (1985DE05). For the earlier work at $E_p = 30.6$ to 56.8 MeV see (1974AJ01, 1979AJ01). See also (1983DE1C), (1984RE14) and (1987KW01, 1987KW03; theor.).

$$46. \text{}^{12}\text{C}(\text{d}, \text{}^8\text{Be})\text{}^6\text{Li} \quad Q_m = -5.892$$

Angular distributions involving several states in ${}^8\text{Be}$ have been studied at $E_d = 19.5$ and 51.8 MeV [see (1974AJ01)] and at 50 MeV (1985GO1G), 54.2 MeV (1984UM04) and 78 MeV (1986JA14), as well as at $E_{\vec{d}} = 18$ and 22 MeV (1987TA07) and 51.7 MeV (1986YA12). See also (1984NE1A, 1987GO1S) and (1987KA1L, theor.).

$$47. \text{}^{12}\text{C}(\text{}^3\text{He}, \text{}^9\text{B})\text{}^6\text{Li} \quad Q_m = -11.570$$

Angular distributions have been obtained at $E(\text{}^3\text{He}) = 28$ to 40.7 MeV [see (1974AJ01)] and at $E(\text{}^3\text{He}) = 33.4$ MeV (1986CL1B; also A_y). See also ${}^9\text{B}$.

$$48. \text{(a) } \text{}^{12}\text{C}(\alpha, \text{}^{10}\text{B})\text{}^6\text{Li} \quad Q_m = -23.712$$
$$\text{(b) } \text{}^{12}\text{C}(\alpha, \text{d}\alpha)\text{}^{10}\text{B} \quad Q_m = -25.1868$$

Angular distributions (reaction (a)) at $E_\alpha = 42$ MeV involve ${}^6\text{Li}^*(0, 2.19)$: see (1974AJ01). At $E_\alpha = 65$ MeV reaction (b) goes via ${}^6\text{Li}^*(2.19, 4.31)$: see (1984AJ01). See also ${}^{10}\text{B}$ and (1987GA20).

$$49. \text{}^{12}\text{C}(\text{}^{10}\text{B}, \text{}^{16}\text{O})\text{}^6\text{Li} \quad Q_m = 2.702$$

See ^{16}O in (1986AJ04).

$$50. \ ^{12}\text{C}(^{12}\text{C}, ^{12}\text{C})2\ ^6\text{Li} \quad Q_m = -28.171$$

The fragmentation of ^{12}C into 2 ^6Li ions has been observed at $E(^{12}\text{C}) = 2.1 \text{ GeV}/A$ (1986LIZP).

$$51. \ ^{12}\text{C}(^{14}\text{N}, ^{20}\text{Ne})^6\text{Li} \quad Q_m = -4.174$$

See ^{20}Ne in (1987AJ02).

$$52. \ ^{13}\text{C}(p, ^8\text{Be})^6\text{Li} \quad Q_m = -8.613$$

See (1974AJ01).

$$53. \ ^{16}\text{O}(d, ^{12}\text{C})^6\text{Li} \quad Q_m = -5.687$$

Angular distributions involving ^6Li ions and several ^{12}C states are reported at $E_d = 22 \text{ MeV}$ (1987TA07) and 51.7 MeV (1986YA12) and at $E_d = 54.2 \text{ MeV}$ (1984UM04). See also (1984NE1A), and ^{12}C in (1990AJ01) for polarization studies.

$$54. \ ^{19}\text{F}(^3\text{He}, ^{16}\text{O})^6\text{Li} \quad Q_m = 4.095$$

Angular distributions have been measured at $E(^3\text{He}) = 11$ to 40.7 MeV involving $^6\text{Li}^*(0, 3.56)$ and various states of ^{16}O : see (1974AJ01, 1977AJ02).

⁶Be
(Figs. 3 and 4)

GENERAL: See also (1984AJ01).

Model calculations: (1986KU1F, 1986VO09, 1987DA1H, 1988DA1D, 1988DA1E, 1988DA1F, 1988KA1J).

Other topics: (1983ANZQ, 1983GR26, 1983SH38, 1984BA1H, 1985AN28, 1986HU1D, 1986KO1N, 1987BA1I, 1987KUZI, 1987SA15).

- | | | |
|--|------------------|----------------|
| 1. (a) ${}^3\text{He}({}^3\text{He}, \gamma){}^6\text{Be}$ | $Q_m = 11.489$ | |
| (b) ${}^3\text{He}({}^3\text{He}, p){}^5\text{Li}$ | $Q_m = 10.89$ | $E_b = 11.489$ |
| (c) ${}^3\text{He}({}^3\text{He}, 2p){}^4\text{He}$ | $Q_m = 12.85966$ | |
| (d) ${}^3\text{He}({}^3\text{He}, {}^3\text{He}){}^3\text{He}$ | | |
| (e) ${}^3\text{He}({}^3\text{He}, pd){}^3\text{He}$ | $Q_m = -5.49354$ | |

The yield of γ -rays to ${}^6\text{Be}^*(1.7)$ (reaction (a)) increases smoothly from 0.4 to 9.3 μb (assuming isotropy) for $0.86 < E({}^3\text{He}) < 11.8$ MeV (90°). No transitions are observed to ${}^6\text{Be}(0)$ [$\sigma < 0.01$ μb at $E({}^3\text{He}) = 1.4$ MeV]. This is understood in terms of a direct capture of ${}^3\text{He}$ by ${}^3\text{He}$ in the singlet spin state and with zero angular momentum: the $0^+ \rightarrow 0^+$ γ -transition is forbidden. Reaction (a) is thus of negligible astrophysical importance compared to reaction (c): see (1979AJ01). The capture cross section from $E({}^3\text{He}) = 12$ MeV to 27 MeV continues to increase smoothly with energy at first and then shows a broad structure centered at $E({}^3\text{He}) = 23 \pm 1$ MeV [$E_x = 23.0 \pm 0.5$ MeV], $\Gamma_{\text{cm}} \approx 5$ MeV. This appears to be a ${}^{33}\text{F}$ cluster resonance which decays by an E1 transition to ${}^6\text{Be}^*(1.7)$. The γ -ray angular distributions are consistent with $J^\pi = 3^-$: see (1979AJ01).

Table 6.6: Energy levels of ${}^6\text{Be}$

E_x (MeV \pm keV)	$J^\pi; T$	Γ_{cm}	Decay	Reactions
g.s.	$0^+; 1$	92 ± 6 keV	p, α	2, 3, 4
1.67 ± 50 ^a	$(2)^+; 1$	1.16 ± 0.06 MeV	p, α	1, 2, 3, 4
23	4^-	broad	γ , ${}^3\text{He}$	1, 3
26	2^-	broad	${}^3\text{He}$	1, 3
27	3^-	broad	${}^3\text{He}$	1

^a See Table 6.8 in (1974AJ01).

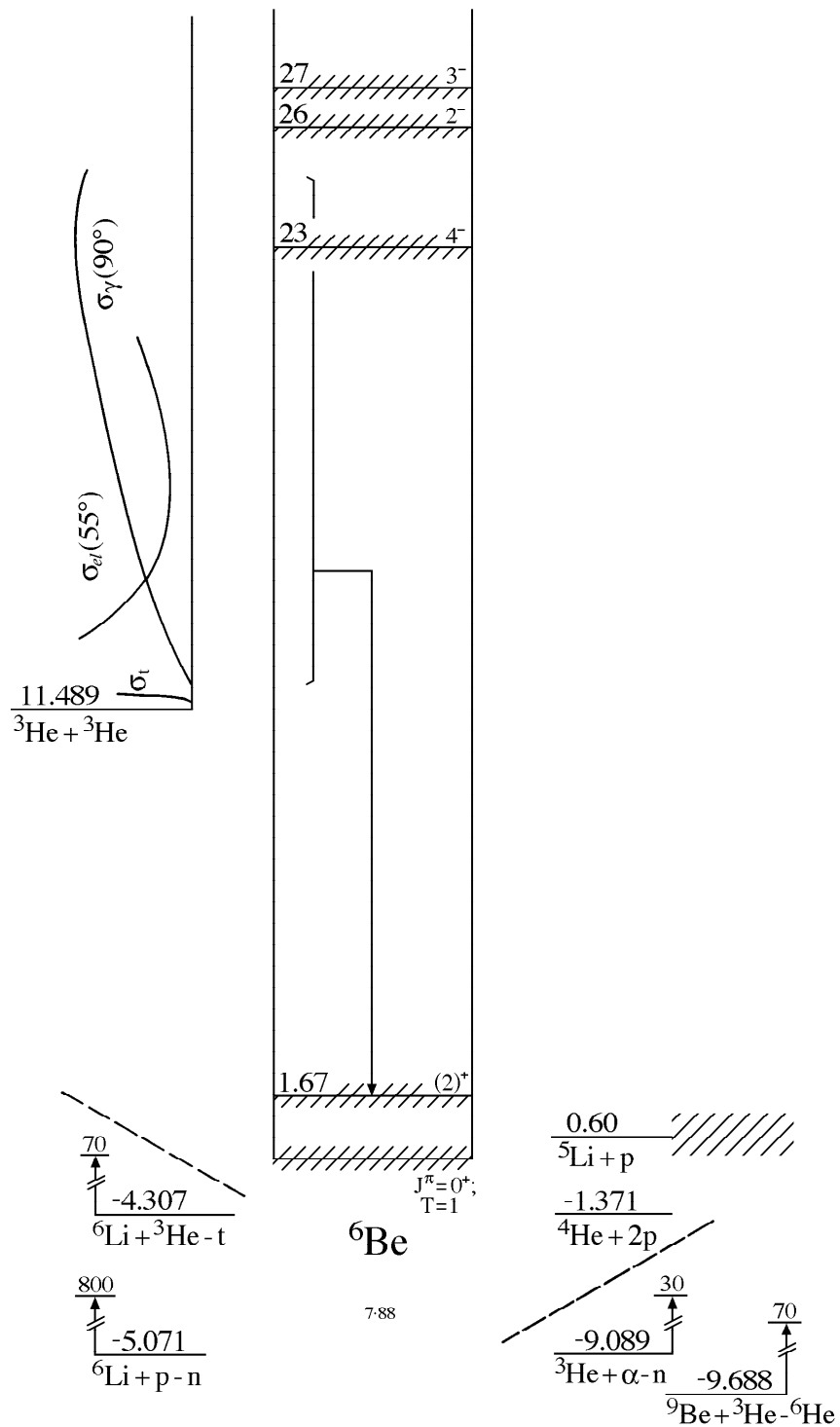

Fig. 3: Energy levels of ${}^6\text{Be}$. For notation see Fig. 1.

A_y has been measured for $E(^3\text{He}) = 14$ to 30 MeV [reaction (b)] by (1983KI10) using a polarized target. See also ^5Li .

Measurements of the total cross section for reaction (c) have been carried out for $E(^3\text{He}) = 60$ keV to 2.2 MeV [see (1979AJ01)] and for 36 to 685 keV (1987KR09). The measurements are consistent with a non-resonant reaction mechanism, at least down to $E_{\text{cm}} = 24.5$ keV. Upper limits for $\omega\gamma$ for a resonance below that energy (and with E_{R} (cm) as low as 16.2 keV) [which might help explain the low observed flux of solar neutrinos], are given in (1987KR09). [It should be noted that a corresponding mirror state in ^6He has not been observed.] The best fit to the data is given by $S(0) = 5.57 \pm 0.31$ MeV \cdot b (1987KR09). See (1979AJ01) for the earlier work. See also (1966LA04, 1974AJ01). For recent work on astrophysical considerations see (1982BA1J, 1982KA1E, 1983FO1A, 1983VO1C, 1984BO1C, 1984DA1H, 1984HA1M, 1985CA41, 1985SC1A, 1986FI15, 1987AS05, 1987RO25, 1988BA86, 1988FO1A). (1985SI12) report α -d correlation measurements at $E(^3\text{He}) = 13.6$ MeV, which suggest the breakup of the diproton (^2He) into $^2\text{H} + e^+ + \nu$.

The elastic scattering (reaction (d)) has been studied for $E(^3\text{He}) = 3$ to 32 MeV and at 120 MeV. The excitation function shows a smooth monotonic behavior except for an anomaly at $E(^3\text{He}) = 25$ MeV in the $L = 3$ partial wave corresponding to a broad state in ^6Be at $E_x \approx 24$ MeV. Polarization measurements have been carried out at $E(^3\text{He}) = 17.9$ to 32.9 MeV. A two level R -matrix analysis of the phase shifts ($L \leq 5$) suggests three broad F-wave states at $E_x \approx 23.4$ (4^-), 26.2 (2^-) and 26.7 MeV (3^-), in disagreement with the capture γ -ray results described above: see (1979AJ01). See also (1984AJ01) and (1986FO04).

A kinematically complete experiment (reaction (e)) has been performed at $E(^3\text{He}) = 120$ MeV: large peaks were observed which appear to correspond to ^3He -d quasi-free scattering followed by p-d FSI: see (1984AJ01).

The total reaction cross sections $\sigma_{\text{R}} = 156.7 \pm 3.8$, 250 ± 14 and 296 ± 12 mb at $E(^3\text{He}) = 17.9$, 21.7 and 24.0 MeV (1987BR02) [see also for partial cross sections for the breakup reactions and for unpublished results for σ_{R} for $E(^3\text{He}) = 3.0$ to 17.9 MeV]. See also (1984AJ01), (1986GOZL, 1986WI1A; applications) and (1983PR09, 1984HA25, 1985HA14, 1986OS1D, 1987AS05, 1988RYZW; theor.).

$$2. \quad ^4\text{He}(^3\text{He}, n)^6\text{Be} \quad Q_{\text{m}} = -9.089$$

Neutron groups to $^6\text{Be}^*(0, 1.7)$ have been observed at $E(^3\text{He}) = 19.4$ to 38.61 MeV: see Table 6.8 in (1974AJ01) for the parameters of the first-excited state. There is no evidence for other states of ^6Be with $E_x \leq 5$ MeV, nor for a state near the ^3He threshold at 11.5 MeV: see (1979AJ01).

$$3. \quad \text{(a) } ^6\text{Li}(p, n)^6\text{Be} \quad Q_{\text{m}} = -5.071$$

$$\quad \quad \quad \text{(b) } ^6\text{Li}(p, pn)^5\text{Li} \quad Q_{\text{m}} = -5.67$$

Neutron groups have been observed to ${}^6\text{Be}^*(0, 1.7)$ as has the ground-state threshold. The width of the ground state is 95 ± 28 keV. The parameters of ${}^6\text{Be}^*(1.7)$ are displayed in Table 6.8 of (1974AJ01). Angular distributions have been reported at $E_p = 8.3$ to 144 MeV [see (1979AJ01, 1984AJ01)] and at 800 MeV (1986KI12). The transverse spin transfer coefficient, $D_{\text{NN}}(0^\circ)$, at $E_p = 160$ MeV for the ground-state transition is -0.37 ± 0.04 in agreement with results in other light nuclei (1984TA07). See also ${}^7\text{Be}$, (1986SA1Q, 1987SA46, 1988HE08), (1984TAZS, 1985GO1F, 1986TA1E, 1987RA32) and (1985SH1C; theor.). In reaction (b) some evidence has been reported at $E_p = 47$ MeV for sequential decay via ${}^6\text{Be}^*(15.5 \pm 2, 24 \pm 2)$: see (1979AJ01). See also (1988MIZX).

4. ${}^6\text{Li}({}^3\text{He}, t){}^6\text{Be}$ $Q_m = -4.307$

Triton groups have been observed to ${}^6\text{Be}^*(0, 1.7)$. The width of the ground state is 89 ± 6 keV. The parameters of the excited state are displayed in Table 6.8 of (1974AJ01). No other excited states have been seen with $E_x < 13$ MeV. There is no evidence for a state near 11.5 MeV: see (1979AJ01). (1987BO39) have studied the decay of ${}^6\text{Be}^*(1.7)$ at $E({}^3\text{He}) = 38.7$ MeV: they report that the branching ratio for decay via the emission of ${}^2\text{He}$ [$T = 1, S = 0$] is 0.60 ± 0.15 : see also reactions 13 in ${}^6\text{He}$ and 32 in ${}^6\text{Li}$ and (1985BO56, 1984BO49, 1988BO1J). See also (1984AJ01), (1987DA31; theor.) and ${}^9\text{B}$.

${}^6\text{B}, {}^6\text{C}$
(Not illustrated)

Not observed: see (1979AJ01, 1984AJ01).

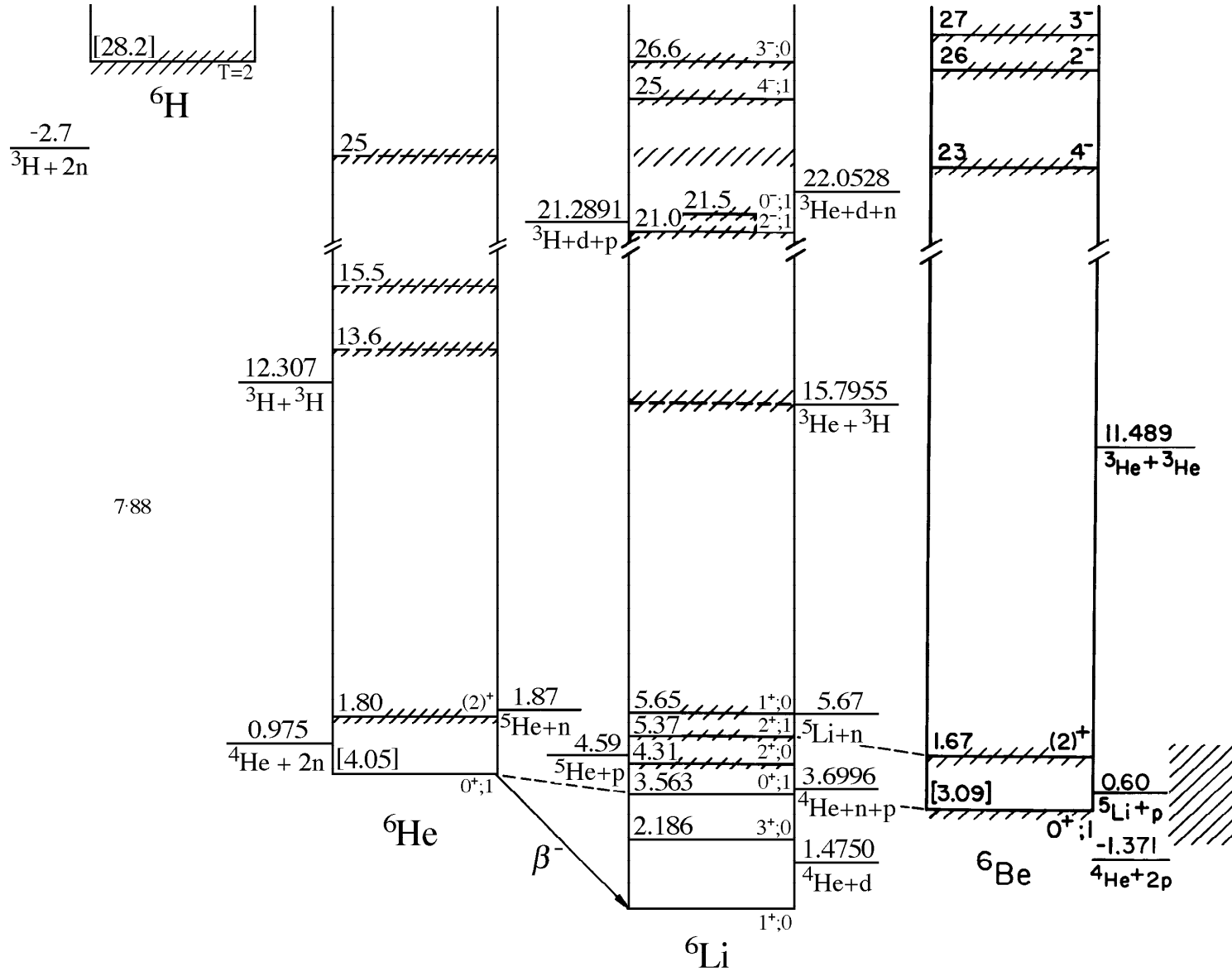

Fig. 4: Isobar diagram, $A = 6$. The diagrams for individual isobars have been shifted vertically to eliminate the neutron-proton mass difference and the Coulomb energy, taken as $E_C = 0.60Z(Z - 1)/A^{1/3}$. Energies in square brackets represent the (approximate) nuclear energy, $E_N = M(Z, A) - ZM(\text{H}) - NM(\text{n}) - E_C$, minus the corresponding quantity for ${}^6\text{Li}$; here M represents the atomic mass excess in MeV. Levels which are presumed to be isospin multiplets are connected by dashed lines.

References

(Closed 1 June 1988)

References are arranged and designated by the year of publication followed by the first two letters of the first-mentioned author's name and then by two additional characters. Most of the references appear in the National Nuclear Data Center files (Nuclear Science References Database) and have NNDC key numbers. Otherwise, TUNL key numbers were assigned with the last two characters of the form 1A, 1B, etc. In response to many requests for more informative citations, we have, when possible, included up to ten authors per paper and added the authors' initials.

- 1966LA04 T. Lauritsen and F. Ajzenberg-Selove, Nucl. Phys. 78 (1966) 1
- 1974AJ01 F. Ajzenberg-Selove and T. Lauritsen, Nucl. Phys. A227 (1974) 1
- 1977AJ02 F. Ajzenberg-Selove, Nucl. Phys. A281 (1977) 1
- 1978GR22 K.A. Gridnev, N.Z. Darvish, A.S. Demyanova, V.M. Semenov, V.B. Subbotin and E.F. Khefter, Izv. Akad. Nauk SSSR Ser. Fiz. 42 (1978) 2361; Bull. Acad. Sci. USSR Phys. Ser. 42 (1978) 124
- 1978LEZA C.M. Lederer, V.S. Shirley, E. Browne, J.M. Dairiki, R.E. Doebler, A.A. Shihab-Eldin, L.J. Jardine, J.K. Tuli and A.B. Buyrn, Table of Isotopes 7th Ed. (1978)
- 1979AJ01 F. Ajzenberg-Selove, Nucl. Phys. A320 (1979) 1
- 1981PL1A G.R. Plattner, Nukleonika 26 (1981)1005
- 1982AL33 D.V. Aleksandrov, Yu.A. Glukhov, A.S. Demyanova, V.I. Dukhanov, I.B. Mazurov, B.G. Novatsky, A.A. Ogloblin, S.B. Sakuta and D.N. Stepanov, Yad. Fiz. 36 (1982) 1351; Sov. J. Nucl. Phys. 36 (1982) 783
- 1982AU1A Audouze and Reeves, Essays in Nucl. Astrophys. (1982) 355
- 1982BA1J Bahcall and Davis, Essays in Nucl. Astrophys. (1982) 243
- 1982BE11 J.C. Bergstrom, S.B. Kowalski and R. Neuhausen, Phys. Rev. C25 (1982) 1156
- 1982BE1D A.M. Bernstein, Proc. Int. School of Intermediate Energy Nucl. Phys., Verona, Italy, July 1981; Eds., R. Bergere, S. Costa and C. Schaerf (1982) 125
- 1982BR25 V.N. Bragin, Yad. Fiz. 36 (1982) 656; Sov. J. Nucl. Phys. 36 (1982) 382
- 1982CA1A Cameron, Essays in Nucl. Astrophys. (1982) 23
- 1982CH28 B. Chen, Chin. J. Nucl. Phys. 4 (1982) 244
- 1982GR1A Greenstein, Essays in Nucl. Astrophys. (1982) 45
- 1982GU21 I.S. Gurbanovich and N.S. Zelenskaya, Yad. Fiz. 36 (1982) 1180; Sov. J. Nucl. Phys. 36 (1982) 688
- 1982KA1D K. Kar and J.C. Parikh, Pramana 19 (1982) 555
- 1982KA1E Kavanagh, Essays in Nucl. Astrophys. (1982) 159
- 1982KI11 J.C. Kim, J. Korean Phys. Soc. 15 (1982) 101

- 1982MO1B Motoba, Proc. Workshop on Hypernucl. Phys., Japan (1982) 36
- 1982RA28 G.M. Radutsky and V.A. Serdyutsky, *Yad. Fiz.* 36 (1982) 857; *Sov. J. Nucl. Phys.* 36 (1982) 501
- 1982WA1A W. Wang, Y. Zhang and R. Wang, *Kexue Tongbao* 27 (1982) 711
- 1982WA1B Wagoner, *Essays in Nucl. Astrophys.* (1982) 495
- 1982WE15 K. Wen, P. Zhang and Z. Sun, *Chin. J. Nucl. Phys.* 4 (1982) 289
- 1983AB1B Abramov et al., *Sov. J. Nucl. Phys.* 38 (1983) 491
- 1983AM1A G. Amsel and J.A. Davies, *Nucl. Instrum. Meth. Phys. Res.* 218 (1983) 177
- 1983AN13 L. Anderson, W. Bruckner, E. Moeller, S. Nagamiya, S. Nissen-Meyer, L. Schroeder, G. Shapiro and H. Steiner, *Phys. Rev. C* 28 (1983) 1224; *Erratum Phys. Rev. C* 28 (1983) 1246
- 1983AN18 M.N. Andronenko, E.N. Volnin, A.A. Vorobev, V.T. Grachev, A.A. Lobodenko, I.I. Straskovsky and L.N. Uvarov, *Pisma Zh. Eksp. Teor. Fiz.* 37 (1983) 446; *JETP Lett. (USSR)* 37 (1983) 530
- 1983ANZQ Y. Ando, M. Uno and M. Yamada, JAERI-M-83-025 (1983)
- 1983AS03 J. Asher and M.T. Swinhoe, *Nucl. Instrum. Meth.* 213 (1983) 503
- 1983AS1B Aslanides et al., in *Florence* (1983) 642
- 1983AV02 G.V. Avakov, E.I. Dolinsky and V.V. Turovtsev, *Yad. Fiz.* 37 (1983) 322; *Sov. J. Nucl. Phys.* 37 (1983) 192
- 1983BA1A Backenstoss et al., in *Florence* (1983) 372
- 1983BA1D H. Bando, *Prog. Theor. Phys.* 69 (1983) 1731
- 1983BA1G Backenstoss et al., *Sin Newsl.* 15 (1983) 31
- 1983BA1L Bando and Nagata, in *Florence* (1983) 688
- 1983BA26 P.D. Barnes, B. Bassalleck, R.A. Eisenstein, G. Franklin, R. Grace, C. Maher, P. Pile, R. Rieder, J. Szymanski, W.R. Wharton et al., *Nucl. Phys. A* 402 (1983) 397
- 1983BA42 J. Bang, J.-J. Benayoun, C. Gignoux and I.L. Thompson, *Nucl. Phys. A* 405 (1983) 126
- 1983BE51 T.L. Belyaeva, N.S. Zelenskaya and I.B. Teplov, *Yad. Fiz.* 38 (1983) 901; *Sov. J. Nucl. Phys.* 38 (1983) 540
- 1983BI13 J.R. Birkelund and J.R. Juizenga, *Ann. Rev. Nucl. Part. Sci.* 33 (1983) 265
- 1983BI1C P.G. Bizzeti, *Riv. Nuovo Cim.* 6 (1983) 1
- 1983BR23 M. Bruno, F. Cannata, M. D'Agostino, B. Jenny, W. Gruebler, V. Konig, P.A. Schmelzbach and P. Doleschall, *Nucl. Phys. A* 407 (1983) 29
- 1983BR31 D.A. Bromley, *Nucl. Phys. A* 400 (1983) 3c

- 1983BR32 F. Brady, G.A. Needham, J.L. Romero, C.M. Castaneda, T.D. Ford, J.L. Ullmann and M.L. Webb, *Phys. Rev. Lett.* 51 (1983) 1320
- 1983BU15 V.V. Burov, O.M. Knyazkov, A.A. Shirokova and K.V. Shitikova, *Z. Phys.* A313 (1983) 319
- 1983BU1A Burkova and Zhusupov, in *Florence* (1983) 345
- 1983CA13 G. Calvi, M. Lattuada, F. Riggi, C. Spitaleri, D. Vinciguerra and D. Miljanic, *Lett. Nuovo Cim.* 37 (1983) 279
- 1983CH23 B. Chambon, D. Drain, C. Pastor, A. Dauchy, A. Giorni and C. Morand, *Z. Phys.* A312 (1983) 125
- 1983CH59 B. Chen, J. Chen, B. Tian and S. Jin, *Chin. J. Nucl. Phys.* 5 (1983) 63
- 1983CO1E H. Conde, T. Andersson, L. Nilsson and C. Nordborg, in *Antwerp 82* (1983) 447
- 1983DA22 J.H. Dave and C.R. Gould, *Phys. Rev.* C28 (1983) 2212
- 1983DE1C R. DeLeo, G. D'Erasmus, S. Micheletti, A. Pantaleo, V. Paticchio, M. Pignanelli and V. Variale, *Rept. INFN/BE-83/9*, 1st. Naz. Fis. Nucl., Bari, Italy (1983)
- 1983DE48 A.S. Demyanova and V.I. Manko, *Yad. Fiz.* 38 (1983) 1189; *Sov. J. Nucl. Phys.* 38 (1983) 716
- 1983DO10 V.N. Dobrikov, O.F. Nemets, A.S. Gass and A.A. Shvedov, *Izv. Akad. Nauk SSSR, Ser. Fiz.* 47 (1983) 943; *Bull. Acad. Sci. USSR Phys. Ser.* 47 (1983) 114
- 1983DZ1A R.I. Dzhibuti, *Fiz. Elem. Chastits At. Yadra* 14 (1983) 741; *Sov. J. Part. Nucl.* 14 (1983) 309
- 1983FE07 V.N. Fetisov, L. Majling, J. Zofka and R.A. Eramzhyan, *Z. Phys.* A314 (1983) 239
- 1983FO03 R. Fonte, *Lett. Nuovo Cim.* 38 (1983) 237
- 1983FO1A Fowler, *AIP Conf. Proc.* 96 (1983) 80
- 1983FU11 Y. Fujiwara and Y.C. Tang, *Phys. Rev.* C28 (1983) 1869
- 1983GA12 F.A. Gareev, S.A. Goncharov, S.N. Ershov, G.S. Kazacha and E. Bang, *Yad. Fiz.* 38 (1983) 73; *Sov. J. Nucl. Phys.* 38 (1983) 41
- 1983GE12 P.M. Gensini, *Lett. Nuovo Cim.* 38 (1983) 469
- 1983GLZZ C.W. Glover, C.C. Foster, P. Schwandt, J.R. Comfort, J. Rapaport, T.N. Taddeucci, D. Wong, J. Seubert and G. Wagner, *Bull. Amer. Phys. Soc.* 28 (1983) 996, EC3
- 1983GM1A M. Gmitro, H.R. Kissener, P. Truol and R.A. Eramzhyan, *Fiz. Elem. Chastits At. Yadra* 14 (1983) 773; *Sov. J. Part. Nucl.* 14 (1983) 323
- 1983GO06 O.K. Gorpinich, E.P. Kadkin, S.N. Kondratev, Yu.N. Lobach, M.V. Pasechnik, L.S. Saltykov and V.V. Tokarevsky, *Izv. Akad. Nauk SSSR Ser. Fiz.* 47 (1983) 185; *Bull. Acad. Sci. USSR Phys. Ser.* 47 (1983) 179
- 1983GO17 V.V. Goryachy and V.V. Peresypkin, *Izv. Akad. Nauk SSSR Ser. Fiz.* 47 (1983) 1013; *Bull. Acad. Sci. USSR Phys. Ser.* 47 (1983) 186

- 1983GO24 V.V. Goryachy and V.V. Peresypkin, *Yad. Fiz.* 38 (1983) 895; *Sov. J. Nucl. Phys.* 38 (1983) 536
- 1983GR26 D.H.E. Gross and M.C. Nemes, *Phys. Lett.* B130 (1983) 131
- 1983GU10 M. Guidetti, P.F. Nali and P. Quarati, *Nuovo Cim.* A75 (1983) 191
- 1983GU1A C. Guet, *Nucl. Phys.* A400 (1983) 191
- 1983GU1B Guinet et al., in *Florence* (1983) 531
- 1983HAYX G.M. Hale, D.C. Dodder and J.C. DeVeaux, in *Antwerp* 82 (1983) 326
- 1983HE17 P. Heusi, H.P. Isaak, H.S. Pruys, R. Engfer, E.A. Hermes, T. Kozlowski, U. Sennhauser and H.K. Walter, *Nucl. Phys.* A407 (1983) 429
- 1983IS10 M. Ishikawa, S. Seki, K. Furuno, Y. Tagishi, M. Sawada, T. Sugiyama, K. Matsuda, T. Murayama, N.X. Dai, J. Sanada et al., *Phys. Rev.* C28 (1983) 1884
- 1983JA13 B. Jakobsson, *Phys. Scr.* T5 (1983) 207
- 1983JE03 B. Jenny, W. Gruebler, V. Konig, P.A. Schmelzbach and C. Schweizer, *Nucl. Phys.* A397 (1983) 61
- 1983JO1A Johnson, Nishioka, Tostevin and Windham, in *Florence* (1983) 505
- 1983JU01 K. Junker, *Nucl. Phys.* A407 (1983) 460
- 1983KA1A S.G. Kadenskii and Yu.L. Ratis, *Yad. Fiz.* 38 (1983) 1325; *Sov. J. Nucl. Phys.* 38 (1983) 805
- 1983KI10 U. Kirchner, R. Beckmann, U. Holm and H.-G. Korber, *Nucl. Phys.* A405 (1983) 159
- 1983KU06 V.I. Kukulín, V.N. Pomerantsev, V.G. Emelyanov and V.I. Klimov, *Yad. Fiz.* 37 (1983) 862; *Sov. J. Nucl. Phys.* 37 (1983) 514
- 1983KU17 N. Kumar, *Nucl. Phys.* A410 (1983) 50
- 1983KU1B A.A. Kuznetsov, *Nucl. Phys.* A400 (1983) 493
- 1983LE14 D.R. Lehman and W.C. Parke, *Phys. Rev.* C28 (1983) 364
- 1983LE26 Y. Le Bornec, F. Hibou, L. Bimbot, T. Hennino, J.C. Jourdain, F. Reide, B. Tatischeff, N. Willis, E. Aslanides, G. Bergdolt et al., *Phys. Lett.* B133 (1983) 149
- 1983LO10 G.J. Lolos, R.R. Johnson, P. Couvert, J. McKenna, R. Myers, I. Spadinger and P. Lorrain, *Phys. Lett.* B126 (1983) 20
- 1983LY04 E.B. Levshin, K.G. Sailer and A.D. Foursat, *Yad. Fiz.* 38 (1983) 633; *Sov. J. Nucl. Phys.* 38 (1983) 377
- 1983MA1F Majling, Zofka, Fetisov and Eramzhyan, in *Orsay* (1983) 19
- 1983MA53 J.F. Mateja, J. Garman and A.D. Frawley, *Phys. Rev.* C28 (1983) 1579
- 1983MI14 S.L. Mintz, *Phys. Rev.* C28 (1983) 1389
- 1983MO1C T. Motoba, H. Bando and K. Ikeda, *Prog. Theor. Phys.* 70 (1983) 189

- 1983MU08 M.J. Murphy and R.G. Stokstad, Phys. Rev. C28 (1983) 428
- 1983NA08 M.N. Namboodiri, R.K. Choudhury, J.B. Natowitz, K. Hagel, L. Adler, P.L. Gonthier, H. Simon, S. Kniffen, R. Patton, E. Tomasi et al., Phys. Rev. C28 (1983) 460
- 1983NO08 E. Norbeck, P.T. Wu, C.R. Chen and R.R. Carlson, Phys. Rev. C28 (1983) 1140
- 1983OL1A D.L. Olson, B.L. Berman, D.E. Greiner, H.H. Heckman, P.J. Lindstrom and H.J. Crawford, Phys. Rev. C28 (1983) 1602
- 1983OS03 A. Osman, Int. J. Theor. Phys. 22 (1983) 341
- 1983OT02 K. Otozai, T. Sekine, R. Arakawa, K. Hata, T. Saito and H. Baba, Z. Phys. A311 (1983) 303
- 1983PO1B Poppe et al., AIP Conf. Proc. 97 (1983) 226
- 1983PO1D Povh, in Florence (1983) 455
- 1983POZX C.H. Poppe, D. Rowley and F.S. Dietrich, Bull. Amer. Phys. Soc. 28 (1983) 969, AD8
- 1983PR09 J. Proriot and B. Jargeaix, Nuovo Cim. A77 (1983) 289
- 1983RE15 M.P. Rekalov, Izv. Akad. Nauk SSSR Ser. Fiz. 47 (1983) 2244; Bull. Acad. Sci. USSR Phys. Ser. 47 (1983) 152
- 1983RO12 R.G.H. Robertson and B.A. Brown, Phys. Rev. C28 (1983) 443
- 1983RU09 K. Rusek, Z. Moroz, R. Caplar, P. Egelhof, K.-H. Mobius, E. Steffens, I. Koenig, A. Weller and D. Fick, Nucl. Phys. A407 (1983) 208
- 1983SA1D G.R. Satchler, Nucl. Phys. A409 (1983) 3
- 1983SA39 Y. Sakuragi, M. Yahiro and M. Kamimura, Prog. Theor. Phys. (Kyoto) 70 (1983) 1047
- 1983SH1E Shi and Zhuang, Phys. Energ. Fortis Phys. Nucl. 7 (1983) 605
- 1983SH1J K. Shibata and S. Shirato, J. Phys. Soc. Jpn. 52 (1983) 3748
- 1983SH24 C.S. Shastri and Y.K. Gambhir, Phys. Rev. C28 (1983) 1109
- 1983SH38 Y.-J. Shi, Phys. Rev. C28 (1983) 2452
- 1983SM04 Yu.F. Smirnov and Yu.M. Tchuvilsky, Czech. J. Phys. B33 (1983) 1215
- 1983ST1A H. Stocker, G. Buchwald, G. Graebner, P. Subramanian, J.A. Maruhn, W. Greiner, B.V. Jacak and G.D. Westfall, Nucl. Phys. A400 (1983) 63
- 1983SU1B Y. Suzuki, Nucl. Phys. A405 (1983) 40
- 1983VA31 A.G.M. van Hees and P.W.M. Glaudemans, Z. Phys. A314 (1983) 323
- 1983VI03 M.F. Vineyard, J. Cook and K.W. Kemper, Nucl. Phys. A405 (1983) 429
- 1983VO1C Vogel, in Dronten (1983) 203
- 1984ABZY B.M. Abramov, I.A. Dukhovskoi, V.V. Kishkurno, L.A. Kondratyuk, A.P. Krutenkova, V.V. Kulikov, M.A. Matsyuk, P.A. Murat, I.A. Radkevich, E.N. Turdakina et al., in Alma Ata (1984) 311

- 1984AJ01 F. Ajzenberg-Selove, Nucl. Phys. A413 (1984) 1
- 1984AK01 A.I. Akhiezer and M.P. Rekalo, Dokl. Akad. Nauk SSSR 274 (1984) 1079; Sov. Phys. Dokl. 24 (1984) 121
- 1984AL08 D.V. Aleksandrov, E.A. Ganza, Yu.A. Glukhov, B.G. Novatsky, A.A. Ogloblin and D.N. Stepanov, Yad. Fiz. 39 (1984) 513; Sov. J. Nucl. Phys. 39 (1984) 323
- 1984AR17 N. Arena, S. Cavallaro, A.S. Figuera, P. D'Agostino, G. Fazio, G. Giardina and F. Mezzanares, Lett. Nuovo Cim. 41 (1984) 59
- 1984AS07 Y.I. Assafiri and I. Morrison, Nucl. Phys. A427 (1984) 460
- 1984BA19 I.Ya. Barit, L.S. Dulkova, E.V. Kuznetsova and N.M. Sobolevsky, Izv. Akad. Nauk SSSR Ser. Fiz. 48 (1984) 380; Bull. Acad. Sci. USSR Phys. Ser. 48 (1984) 159
- 1984BA1H I. Bang and Yu.V. Gaponov, Izv. Akad. Nauk SSSR Ser. Fiz. 48 (1984) 129; Bull. Acad. Sci. USSR Phys. Ser. 51 (1984) 130
- 1984BA1U Bayukov et al., in Panic (1984) I25
- 1984BA53 J. Bang, F.A. Gareev, S.A. Goncharov and G.S. Kazacha, Nucl. Phys. A429 (1984) 330
- 1984BE1E Benenson, Bull. Amer. Phys. Soc. 29 (1984) 1046
- 1984BE37 R. Beck, F. Dickmann and A.T. Kruppa, Phys. Rev. C30 (1984) 1044
- 1984BL21 L.D. Blokhintsev, A.M. Mukjamedzhanov and A.N. Safronov, Fiz. Elem. Chastits At. Yad. 15 (1984) 1296; Sov. J. Part. Nucl 15 (1984) 580
- 1984BO03 A.I. Boothroyd, J. Markey and P. Vogel, Phys. Rev. C29 (1984) 603
- 1984BO1C Boyd, Turner, Rybarczyk and Joseph, Private Communication (1984)
- 1984BO1D A.R. Bodmer, Q.N. Usmani and J. Carlson, Nucl. Phys. A422 (1984) 510
- 1984BO1G A.R. Bodmer, AIP Conf. Proc. 123 (1984) 806
- 1984BO1H L.N. Bogdanova and V.E. Markushin, Fiz. Elem. Chastits At. Yadra 15 (1984) 808; Sov. J. Part. Nucl. 15 (1984) 361
- 1984BO49 O.V. Bochkarev, A.A. Korshennikov, E.A. Kuzmin, I.G. Mukha, A.A. Ogloblin, L.V. Chulkov and G.B. Yankov, Pisma Zh. Eksp. Teor. Fiz. 40 (1984) 204; JETP Lett. (USSR) 40 (1984) 969
- 1984BR03 F.P. Brady, G.A. Needham, J.L. Ullmann, C.M. Castaneda, T.D. Ford, N.S.P. King, J.L. Romero, M.L. Webb, V.R. Brown and C.H. Poppe, J. Phys. G10 (1984) 363
- 1984BR04 J. Brzychczyk, L. Freindl, K. Grotowski, Z. Majka, S. Micek, R. Planeta, M. Albinska, J. Buschmann, H. Klewe-Nebenius, H.J. Gils et al., Nucl. Phys. A417 (1984) 174
- 1984BR08 I.M. Brancus, A. Constantinescu, I. Lazar, I. Mihai, M. Petrascu, A.S. Demianova, A.A. Ogloblin and S.B. Sakuta, Rev. Roum. Phys. 29 (1984) 77

- 1984BR1B Bragin and Tompson, in Alma Ata (1984) 460
- 1984BR22 T. Bressani, E. Chiavassa, S. Costa, G. Dellacasa, N. De Marco, M. Gallio, A. Musso, E. Aslanides, G. Bergdolt, P. Fassnacht et al., Phys. Rev. C30 (1984) 1745
- 1984BR25 B.A. Brown, C.R. Bronk and P.E. Hodgson, J. Phys. G10 (1984) 1683
- 1984BR28 V.N. Bragin, Izv. Akad. Nauk SSSR Ser. Fiz. 48 (1984) 182; Bull. Acad. Sci. USSR Phys. Ser. 48 (1984) 184
- 1984BU01 V.V. Burov, V.M. Dubovik, S.G. Kadmsky, Yu.M. Tchuvisky and L.A. Tosunyan, J. Phys. G10 (1984) L21
- 1984BU1C Burkova, Glozman and Zhusupov, in Alma Ata (1984) 368
- 1984BY1A V.M. Bystritsky, V.P. Dzhelepov, A. Gula, V.A. Stolupin and J. Wozniak, Acta Phys. Pol. B15 (1984) 699
- 1984BY1B V.M. Bystritsky, V.P. Dzhelepov, A. Gula, J. Wozniak and V.G. Zinov, Acta Phys. Pol. B15 (1984) 689
- 1984CH16 E. Chiavassa, S. Costa, G. Dellacasa, N. De Marco, M. Gallio, A. Musso, E. Aslanides, P. Fassnacht, F. Hibou, T. Bressani et al., Nucl. Phys. A422 (1984) 621
- 1984CH1E B. Chen, B. Sa and X. Zhang, Chin. J. Nucl. Phys. 6 (1984) 129
- 1984CH1G H. Chen, F. Zhuang, X. Shi and X. Jin, Chin. J. Nucl. Phys. 6 (1984) 303
- 1984CH20 I.-T. Cheon, S.J. Choi and M.T. Jeong, Phys. Lett. B144 (1984) 312
- 1984CO08 J. Cook, Nucl. Phys. A417 (1984) 477
- 1984DA1H Davis, AIP Conf. Proc. 123 (1984) 1037
- 1984DE52 F.W.N. de Boer, R. van Dantzig, M. Daum, J. Jansen, P.J.S. Watson, L. Felawka, C. Grab, A. van der Schaaf, T. Kozlowski, J. Martino and A.I. Smirnov, Phys. Rev. Lett. 53 (1984) 423
- 1984DE53 P. De Bievre, M. Gallet, N.E. Holden and I.L. Barnes, J. Phys. Chem. Ref. Data 13 (1984) 809
- 1984DO20 T.W. Donnelly and I. Sick, Rev. Mod. Phys. 56 (1984) 461
- 1984DU17 S.B. Dubovichenko and M.A. Zhusupov, Izv. Akad. Nauk SSSR Ser. Fiz. 48 (1984) 935; Bull. Acad. Sci. USSR Phys. Ser. 48 (1984) 95
- 1984DY01 N. Dytlewski, S.A. Siddiqui and H.H. Thies, Nucl. Phys. A430 (1984) 214
- 1984DZ1A R.I. Dzhibuti and Sh.M. Tsiklauri, Yad. Fiz. 39 (1984) 1115; Sov. J. Nucl. Phys. 39 (1984) 704
- 1984EC01 J.S. Eck, K.W. Kemper and T.R. Ophel, Nucl. Phys. A425 (1984) 141
- 1984EF03 V.P. Efrosinin and D.A. Zaikin, Yad. Fiz. 39 (1984) 1135; Sov. J. Nucl. Phys. 39 (1984) 717
- 1984EV1A Evlanov, Polozov and Sokolov, in Alma Ata (1984) 431

- 1984FE1A Ferch et al., INDC (CCP)-221/L (1984) 18
- 1984FI14 G.F. Filippov, V.S. Vasilevsky and S.P. Kruchinin, *Yad. Fiz.* 40 (1984) 357; *Sov. J. Nucl. Phys.* 40 (1984) 229
- 1984FI1F V.V. Filchenkov, L.N. Somov and V.G. Zinov, *Nucl. Instrum. Meth. Phys. Res.* A228 (1984) 174
- 1984FIZW G.F. Filippov, V.S. Vasilevsky and A.V. Nesterov, in *Alma Ata* (1984) 209
- 1984FR13 H. Friedrich, *Phys. Lett.* B146 (1984) 135
- 1984GE05 J.-F. Germond and C. Wilkin, *J. Phys.* G10 (1984) 745
- 1984GE1B Germond, in *Panic* (1984) F26
- 1984GL02 L.Ya. Glozman, V.I. Kukulkin and V.G. Neudatchin, *Phys. Lett.* B136 (1984) 315
- 1984GL06 Yu.A. Glukhov, A.S. Demyanova, A.A. Ogloblin, S.B. Sakuta and V.V. Sukharevsky, *Yad. Fiz.* 40 (1984) 62; *Sov. J. Nucl. Phys.* 40 (1984) 41
- 1984GL09 L.Ya. Glozman, V.I. Kukulkin and V.G. Neudatchin, *Nucl. Phys.* A430 (1984) 589
- 1984GO03 A. Gokmen, H. Breuer, A.C. Mignerey, B.G. Glagola, K. Kwiatkowski and V.E. Viola, Jr., *Phys. Rev.* C29 (1984) 1595
- 1984GR05 G. Grawert and D. Mukhopadhyay, *Nucl. Phys.* A415 (1984) 304
- 1984GR08 R.E.L. Green, R.G. Korteling and K.P. Jackson, *Phys. Rev.* C29 (1984) 1806
- 1984GR20 K. Grotowski, Z. Majka, R. Planeta, M. Szczodrak, Y. Chan, G. Guarino, L.G. Moretto, D.J. Morrissey, L.G. Sobotka, R.G. Stokstad, I. Tserruya et al., *Phys. Rev.* C30 (1984) 1214
- 1984GU06 R. Guigas, P. Blum, H. Koch, M. Meyer, H. Poth, U. Raich, B. Richter, G. Backenstoss, P. Pavlopoulos, L. Tauscher et al., *Phys. Lett.* B137 (1984) 323
- 1984GU09 S.K. Gupta and S. Kailas, *Z. Phys.* A317 (1984) 75
- 1984GU14 P.C. Gugelot, *Phys. Rev.* C30 (1984) 654
- 1984HA1D D. Halderson, *Phys. Rev.* C30 (1984) 941
- 1984HA1M Haxton, *AIP Conf. Proc.* 123 (1984) 1026
- 1984HA25 M. Hanck, Y.C. Tang and D. Baye, *Nucl. Phys.* A419 (1984) 308
- 1984HA53 Q. Haider and F.B. Malik, *At. Data Nucl. Data Tables* 31 (1984) 185
- 1984HI1A A.S. Hirsch, A. Bujak, J.E. Finn, L.J. Gutay, R.W. Minich, N.T. Porile, R.P. Scharenberg and B.C. Stringfellow, *Phys. Rev.* C29 (1984) 508
- 1984IR1A Irgaziev, Yarmukhamedov and Avakov, in *Panic* (1984) A33
- 1984JI03 R.I. Jibuti and R.Ya. Kezerashvili, *Nucl. Phys.* A430 (1984) 573
- 1984JO1A Johnson, *Proc. 4th Int. Conf. Clustering Aspects of Nucl. Struct.*, Chester, England, 1984 (1985) 155

- 1984KA1E H. Kanada, T. Kaneko, M. Nomoto and Y.C. Tang, *Prog.Theor. Phys.* 72 (1984) 369
- 1984KE1C B.O. Kerbikov, *Yad. Fiz.* 39 (1984) 816; *Sov. J. Nucl. Phys.* 39 (1984) 516
- 1984KH05 S.A.F. Khallaf, *Fizika (Zagreb)* 16 (1984) 285
- 1984KI08 B.T. Kim, T. Udagawa and T. Tamura, *Phys. Rev. C*30 (1984) 1087
- 1984KI16 R.R. Kiziah, M.D. Brown, C.J. Harvey, D.S. Oakley, D.P. Saunders, P.A. Seidl, C.F. Moore, W.B. Cottingham, R.W. Garnett, S.J. Greene et al., *Phys. Rev. C*30 (1984) 1643
- 1984KO16 K. Kobayashi and T. Kohmura, *Prog. Theor. Phys. (Kyoto)* 71 (1984) 327
- 1984KO1A Koenig et al., *Bull. Amer. Phys. Soc.* 29 (1984) 672
- 1984KO1E Komarov, Muller and Tesch, in *Panic* (1984) 120
- 1984KO1H D.P. Kostomarov, V.I. Kukulín and P.B. Sazonov, *Moscow Univ. Comput. Math. Cybern. (USA)* 1 (1984) 1; *Vestn. Mosk. Univ.* 15, *Vychisl. Mat. Kibern. (USSR)* 1 (1984) 3
- 1984KO25 I. Koenig, D. Fick, S. Kossionides, P. Egelhof, K.-H. Mobius and E. Steffens, *Z. Phys.* A318 (1984) 135
- 1984KR10 V.M. Krasnopolskii, V.I. Kukulín and V.G. Neudachin, *Izv. Akad. Nauk SSSR Ser. Fiz.* 48 (1984) 84; *Bull. Acad. Sci. USSR Phys. Ser.* 48 (1984) 82
- 1984KR1B A.V. Kravtsov, N.P. Popov and G.E. Solvakin, *Pisma Zh. Eksp. Teor. Fiz.* 40 (1984) 124; *JETP Lett. (USSR)* 40 (1984) 875
- 1984KU03 V.I. Kukulín, V.M. Krasnopolsky, V.T. Voronchev and P.B. Sazonov, *Nucl. Phys.* A417 (1984) 128
- 1984KU06 V.I. Kukulín and V.V. Peresypkin, *Yad. Fiz.* 39 (1984) 412; *Sov. J. Nucl. Phys.* 39 (1984) 259
- 1984KU13 A.E. Kudrjavitsev, V.D. Mur and V.S. Popov, *Phys. Lett.* B143 (1984) 41
- 1984KU15 V.I. Kukulín, M. Kamal, V.T. Voronchev and V.M. Krasnopolsky, *J. Phys.* G10 (1984) L213
- 1984LA19 M. Lattuada, F. Riggi, C. Spitaleri, D. Vinciguerra, G. Vourvopoulos, X. Aslanoglou and D. Miljanic, *Phys. Rev. C*30 (1984) 531
- 1984LA27 M. Langevin, C. Detraz, M. Epherre, D. Guillemaud-Mueller, B. Jonson, C. Thibault and the ISOLDE Collaboration, *Phys. Lett.* B146 (1984) 176
- 1984LA33 M. Lattuada, F. Riggi, C. Spitaleri and D. Vinciguerra, *Nuovo Cim.* A83 (1984) 151
- 1984LO1C Lovas, *Proc. 4th Int. Conf. Clustering Aspects of Nucl. Struct.*, Chester, England, 1984 (1985) 231
- 1984MA1G Majling, Sotona, Zofka and Fetisov, in *Panic* (1984) M20
- 1984MI1A Mikhelamvili, in *Alma Ata* (1984) 216

- 1984MI1E D.J. Millener, AIP Conf. Proc. 123 (1984) 850
- 1984MI1F Mihailovic, Proc. 4th Int. Conf. Clustering Aspects of Nucl. Struct., Chester, England, 1984 (1985) 85
- 1984MIZM I.A. Mitropolsky and E.F. Hefter, in Alma Ata (1984) 241
- 1984MO09 T. Motoba, H. Bando and K. Ikeda, Prog. Theor. Phys. 71 (1984) 222
- 1984MO1H T. Motoba, H. Bando and K. Ikeda, Proc. Int. Summer School, Changchun, China, 1983 (1984) 702
- 1984MO29 D.J. Morrissey, W. Benenson, E. Kashy, B. Sherrill, A.D. Panagiotou, R.A. Blue, R.M. Ronningen, J. van der Plicht and H. Utsunomiya, Phys. Lett. B148 (1984) 423
- 1984MU01 B.A. Mughrabi, Z. El Itaoui, P.J. Ellis and Y.C. Tang, Phys. Rev. C29 (1984) 29
- 1984MU1D D. Mukhopadhyay and G. Grawert, J. Phys. (Paris) 45 (1984) C6-435
- 1984NA17 V.S. Nadezhdin, N.I. Petrov, V.I. Satarov and A.M. Rozanova, Yad. Fiz. 40 (1984) 27; Sov. J. Nucl. Phys. 40 (1984) 17
- 1984NA19 S. Nakaichi-Maeda and E.W. Schmid, Z. Phys. A318 (1984) 171
- 1984NA1D S. Nagamiya, J. Randrup and T.J.M. Symons, Ann. Rev. Nucl. Part. Sci. 34 (1984) 155
- 1984NE1A Nemets, Rudchik and Chuvilski, in Alma Ata (1984) 334
- 1984NI01 H. Nishioka, J.A. Tostevin, R.C. Johnson and K.-I. Kubo, Nucl. Phys. A415 (1984) 230
- 1984OH01 H. Ohnishi, M. Tanifuji, M. Kamimura, Y. Sakuragi and M. Yahiro, Nucl. Phys. A415 (1984) 271
- 1984PA08 W.C. Parke and D.R. Lehman, Phys. Rev. C29 (1984) 2319; Erratum Phys. Rev. C34 (1986) 1496
- 1984PA1B Pasechnik et al., in Alma Ata 84 (1984) 288
- 1984PL1A G.-R. Plattner, Nucl. Phys. A416 (1984) 565
- 1984PU1A Pugach et al., in Alma Ata (1984) 386
- 1984RA1E N.C. Rana, Nuovo Cim. B84 (1984) 53
- 1984RE14 S.M. Read and V.E. Viola, Jr., At. Data Nucl. Data Tables 31 (1984) 359
- 1984RE1C M.P. Rekalov, Dopov. Akad. Nauk UKRSR Ser. A7 (1984) 62
- 1984REZZ D.S. Resler, H.D. Knox, R.O. Lane and S.M. Grimes, Bull. Amer. Phys. Soc. 29 (1984) 629, AG3
- 1984RO04 R.G.H. Robertson, P. Dyer, R.C. Melin, T.J. Bowles, A.B. McDonald, G.C. Ball, W.G. Davies and E.D. Earle, Phys. Rev. C29 (1984) 755
- 1984RO1B Romanov and Grechukhin, in Alma Ata (1984) 280, 281

- 1984SA1B Saupe, Shirokova and Shitikova, in Alma Ata (1984) 474
- 1984SA39 L. Satta, J. Duflo, F. Plouin, P. Picozza, L. Goldzahl, J. Banaigs, R. Frascaria, F.L. Fabbri, A. Codino, J. Berge et al., Phys. Lett. B139 (1984) 263
- 1984SC1A E.W. Schmid, Nucl. Phys. A416 (1984) 347
- 1984SHZJ A.A. Shvedov, V.N. Dobrikov and O.F. Nemets, in Alma-Ata (1984) 332
- 1984SM04 G.R. Smith, J.R. Shepard, R.L. Boudrie, R.J. Peterson, G.S. Adams, T.S. Bauer, G.J. Igo, G. Pauletta, C.A. Whitten, Jr., A. Wriekat et al., Phys. Rev. C30 (1984) 593
- 1984ST1B R.G. Stokstad, Comments on Nucl. Part. Phys. 13 (1984) 231
- 1984SU09 D. Sundholm, P. Pyykko, L. Laaksonen and A. Sadlej, Chem. Phys. Lett. 112 (1984) 1
- 1984TA07 T.N. Taddeucci, T.A. Carey, C. Gaarde, J. Larsen, C.D. Goodman, D.J. Horen, T. Masterson, J. Rapaport, T.P. Welch and E. Sugarbaker, Phys. Rev. Lett. 52 (1984) 1960
- 1984TAZS T.N. Taddeucci, Bull. Amer. Phys. Soc. 29 (1984) 1032, BA4
- 1984TR1B V.A. Tryasuchev, Yad. Fiz. 39 (1984) 602; Sov. J. Nucl. Phys. 39 (1984) 380
- 1984TR1C J.W. Truran, Ann. Rev. Nucl. Part. Sci. 34 (1984) 53
- 1984TS03 M.B. Tsang, D.R. Klesch, C.B. Chitwood, D.J. Fields, C.K. Gelbke, W.G. Lynch, H. Utsunomiya, K. Kwiatkowski, V.E. Viola, Jr. and M. Fatyga, Phys. Lett. B134 (1984) 169
- 1984TU02 M. Turk and B. Antolkovic, Nucl. Phys. A431 (1984) 381
- 1984UD1A M.A. Uddin and M.S. Ali, Bangladesh Acad. Sci. 8 (1984) 19
- 1984UM04 K. Umeda, T. Yamaya, T. Suehiro, K. Takimoto, R. Wada, E. Takada, S. Shimoura, A. Sakaguchi, S. Murakami, M. Fukada et al., Nucl. Phys. A429 (1984) 88
- 1984VA06 A.G.M. van Hees and P.W.M. Glaudemans, Z. Phys. A315 (1984) 223
- 1984VA1B Vasilevsky, Chopovski and Phillipov, in Alma Ata (1984) 197
- 1984VI01 M.F. Vineyard, K.W. Kemper and J. Cook, Phys. Lett. B142 (1984) 249
- 1984VI02 M.F. Vineyard, J. Cook, K.W. Kemper and M.N. Stephens, Phys. Rev. C30 (1984) 916
- 1984WA02 H. Walliser and Y.C. Tang, Phys. Lett. B135 (1984) 344
- 1984WA09 R.E. Warner, R.S. Wakeland, J.-Q. Yang, D.L. Friesel, P. Schwandt, G. Caskey, A. Galonsky, B. Remington and A. Nadasen, Nucl. Phys. A422 (1984) 205
- 1984WA18 M.W. Wade, M.K. Brussel, L.J. Koester, Jr. and J.H. Smith, Phys. Rev. Lett. 53 (1984) 2540
- 1984WA1H L.-H. Wang, F.-A. Zeng and X. Zhao, Phys. Energ. Fortis Phys. Nucl. 8 (1984) 328
- 1984WA1J J.D. Walecka, AIP Conf. Proc. 123 (1984) 1

- 1984WE03 G.D. Westfall, Z.M. Koenig, B.V. Jacak, L.H. Harwood, G.M. Crawley, M.W. Curtin, C.K. Gelbke, B. Hasselquist, W.G. Lynch, A.D. Panagiotou et al., Phys. Rev. C29 (1984) 861
- 1984WI08 G. Windham, H. Nishioka, J.A. Tostevin and R.C. Johnson, Phys. Lett. B138 (1984) 253
- 1984YP01 K. Ypsilantis and M.E. Grypeos, Nuovo Cim. A82 (1984) 93
- 1984ZA1A M. Zamani, K. Zioutas and S. Charalambous, Nucl. Tracks Radiat. Meas. 8 (1984) 555
- 1984ZH1A Zhusupov, Shaksibekova and Ibraeva, in Alma Ata (1984) 411
- 1984ZH1B F. Zhuang, H.-Z. Chen and X.-N. Jin, Phys. Energ. Fortis Phys. Nucl. 8 (1984) 215
- 1984ZW1A Zwartz, Unpublished Ph.D. Thesis, Utrecht (1984)
- 1985AJ01 F. Ajzenberg-Selove, Nucl. Phys. A433 (1985) 1; Erratum Nucl. Phys. A449 (1986) 155
- 1985AK1B I. Akhiezer and M.P. Rekalov, Dokl. Akad. Nauk SSSR 280 (1985) 83; Sov. Phys. Dokl. (USA) 30 (1985) 45
- 1985AL12 Y. Alhassid, G. Maddison, K. Langanke, K. Chow and S.E. Koonin, Z. Phys. A321 (1985) 677
- 1985AL16 G.D. Alkharov, S.L. Belostotsky, A.A. Vorobyov, O.A. Domchenkov, Yu.V. Dotsenko, N.P. Kuropatkin and V.N. Nikulin, Yad. Fiz. 42 (1985) 8; Sov. J. Nucl. Phys. 42 (1985) 4
- 1985AL1G Aleksandrov et al., in Questions in At. Phys. and in Tech., USSR (1985) 3
- 1985AN28 M.S. Antony, J. Britz, J.B. Bueb and A. Pape, At. Data Nucl. Data Tables 33 (1985) 447
- 1985BA1C B.F. Bayman, S. Fricke and Y.C. Tang, Phys. Rev. C31 (1985) 679
- 1985BA1E H. Bando, Prog. Theor. Phys. Suppl. 81 (1985) 1
- 1985BA68 F.C. Barker and C.L. Woods, Aust. J. Phys. 38 (1985) 563
- 1985BAYZ I.Ya. Barit, Yu.G. Balashko, L.S. Dulkova and S.V. Zuev, in Leningrad (1985) 307
- 1985BE1C Berdnikov et al., in Leningrad (1985) 302
- 1985BE30 S.L. Belostotsky, S.S. Volkov, A.A. Vorobyev, Yu.V. Dotsenko, L.G. Kudin, N.P. Kuropatkin, O.V. Miklukho, V.N. Nikulin and O.E. Prokofyev, Yad. Fiz. 41 (1985) 1425; Sov. J. Nucl. Phys. 41 (1985) 903
- 1985BE60 R. Beck, F. Dickmann and R.G. Lovas, Nucl. Phys. A446 (1985) 703
- 1985BL18 J. Blocki, K. Grotowski, R. Planeta and W.J. Swiatecki, Nucl. Phys. A445 (1985) 367
- 1985BO05 M. Bouten, M.C. Bouten and T. Cornelissens, J. Phys. G11 (1985) 231

- 1985BO11 O.V. Bochkarev, A.A. Korshennikov, E.A. Kuzmin, I.G. Mukha, L.V. Chulkov and G.B. Yankov, *Yad. Fiz.* 41 (1985) 31; *Sov. J. Nucl. Phys.* 41 (1985) 19
- 1985BO1E R.N. Boyd, R.E. Turner, B. Sur, L. Rybarchyk and C. Joseph, *AIP Conf. Proc.* 126 (1985) 145
- 1985BO1J A.S. Botvina, A.S. Il'inov and I.N. Mishustin, *Yad. Fiz.* 42 (1985) 1127; *Sov. J. Nucl. Phys.* 42 (1985) 712
- 1985BO1K Boesgaard and Steigman, *Ann. Rev. Astron. Astrophys.* 23 (1985) 319
- 1985BO55 O.V. Bochkarev, A.A. Korshennikov, E.A. Kuzmin, I.G. Mukha, A.A. Ogloblin, L.V. Chulkov and G.B. Yankov, *Pisma Zh. Eksp. Teor. Fiz.* 42 (1985) 303; *JETP Lett. (USSR)* 42 (1985) 374
- 1985BO56 O.V. Bochkarev, A.A. Korshennikov, E.A. Kuzmin, I.G. Mukha, A.A. Ogloblin, L.V. Chulkov and G.B. Yankov, *Pisma Zh. Eksp. Teor. Fiz.* 42 (1985) 305; *JETP Lett. (USSR)* 42 (1985) 377
- 1985BR14 V.N. Bragin and I.J. Thompson, *Yad. Fiz.* 41 (1985) 314; *Sov. J. Nucl. Phys.* 41 (1985) 199
- 1985BU1B M. Bubak, V.M. Bystritsky and A. Gula, *Acta Phys. Pol.* B16 (1985) 575
- 1985CA1B J.M. Cameron, *Nucl. Phys.* A434 (1985) 261
- 1985CA41 G.R. Caughlan, W. A. Fowler, M.J. Harris and B.A. Zimmerman, *At. Data Nucl. Data Tables* 32 (1985) 197
- 1985CH01 C.T. Christou, C.J. Seftor, W.J. Briscoe, W.C. Parke and D.R. Lehman, *Phys. Rev.* C31 (1985) 250
- 1985CH37 S. Chiba, M. Baba, H. Nakashima, M. Ono, N. Yabuta, S. Yukinori and N. Hirakawa, *J. Nucl. Sci. Tech. (Tokyo)* 22 (1985) 771
- 1985CL1A F.E. Close, *Nucl. Phys.* A446 (1985) 273
- 1985CO09 J. Cook and K.W. Kemper, *Phys. Rev.* C31 (1985) 1745
- 1985CO21 J. Cook, *Nucl. Phys.* A445 (1985) 350
- 1985CU04 A. Cunsolo, A. Foti, G. Imme, G. Pappalardo, G. Raciti, F. Rizzo and N. Saunier, *Nuovo Cim.* A85 (1985) 343
- 1985DA29 V. D'Amico, G. Fazio, S. Femino, G. Giardina, A. Italiano and F. Mezzanares, *Can. J. Phys.* 63 (1985) 1438
- 1985DE05 G. D'Erasmus, V. Variale and A. Pantaleo, *Phys. Rev.* C31 (1985) 656
- 1985DE17 E. Descroix, M. Bedjidian, J.Y. Grossiord, A. Guichard, M. Gusakow, M. Jacquin, J.R. Pizzi and G. Bagieu, *Nucl. Phys.* A438 (1985) 112
- 1985DO03 P. Doleschall, Gy. Bencze, M. Bruno, F. Cannata and M. D'Agostino, *Phys. Lett.* B152 (1985) 1

- 1985DO16 Yu.V. Dotsenko and V.E. Starodubsky, *Yad. Fiz.* 42 (1985) 107; *Sov. J. Nucl. Phys.* 42 (1985) 66
- 1985DO19 M. Dorr, W. Fetscher, D. Gotta, J. Reich, H. Ullrich, G. Backenstoss, W. Kowald and H.-J. Weyer, *Nucl. Phys.* A445 (1985) 557; *Erratum Nucl. Phys.* A457 (1986) 742
- 1985DU05 O. Dumbrajs, *Phys. Scr.* 31 (1985) 485
- 1985EM01 V.G. Emelyanov, V.I. Klimov and V.N. Pomerantsev, *Phys. Lett.* B157 (1985) 105
- 1985ER06 R.A. Eramzhyan, T.D. Kaipov and S.S. Kamalov, *Z. Phys.* A322 (1985) 321
- 1985FA02 H. Faissner, B.R. Kim and H. Reithler, *Phys. Rev. Lett.* 54 (1985) 1902
- 1985FI01 G.F. Filippov, V.S. Vasilevskii and A.V. Nesterov, *Izv. Akad. Nauk SSSR Ser. Fiz.* 49 (1985) 173; *Bull. Acad. Sci. USSR Phys. Ser.* 49 (1985) 182
- 1985FI1E G.F. Filippov, V.S. Vasilevskii and L.L. Chopovskii, *Fiz. Elem. Chastits At. Yadra* 16 (1985) 349; *Sov. J. Part. Nucl.* 16 (1985) 153
- 1985FR01 R. Franke, K. Kochskamper, B. Steinheuer, K. Wingender, W. Von Witsch and H. Machner, *Nucl. Phys.* A433 (1985) 351
- 1985FR1F V. Franco and Y. Yin, *Phys. Rev. Lett.* 55 (1985) 1059
- 1985GL06 Yu.A. Glukhov, A.S. Demyanova, A.A. Ogloblin, S.B. Sakuta, I. Berceanu and I. Mihai, *Yad. Fiz.* 42 (1985) 561; *Sov. J. Nucl. Phys.* 42 (1985) 355
- 1985GO07 P. Goldhammer, *Phys. Rev.* C31 (1985) 1533
- 1985GO1F Goodman, *AIP Conf. Proc.* 124 (1985) 375
- 1985GO1G Gorionov et al., in *Leningrad* (1985) 310
- 1985GO20 J. Gomez-Camacho, M. Lozano and M.A. Nagarajan, *Phys. Lett.* B161 (1985) 39
- 1985GO23 J. Gomez-Camacho and M.A. Nagarajan, *J. Phys.* G11 (1985) L239
- 1985GR1A L. Grenacs, *Ann. Rev. Nucl. Part. Sci.* 35 (1985) 455
- 1985GU11 S.K. Gupta, S. Kailas, N. Lingappa and A. Shridhar, *Phys. Rev.* C31 (1985) 1965
- 1985GU1G A. Gula, *Acta Phys. Pol.* B16 (1985) 589
- 1985GU1J K.K. Gudima and V.D. Toneev, *Yad. Fiz.* 42 (1985) 645; *Sov. J. Nucl. Phys.* 42 (1985) 409
- 1985HA04 K. Hahn, E.W. Schmid and P. Doleschall, *Phys. Rev.* C31 (1985) 325
- 1985HA14 M. Hanck, *Nucl. Phys.* A439 (1985) 1
- 1985HA18 S.S. Hanna and J.W. Hugg, *Hyperfine Interactions* 21 (1985) 59
- 1985HO1A L.M. Hobbs, *Astrophys. J.* 290 (1985) 284
- 1985HO1E Hofmann, NEANDC-222 U; Specialists' Meeting on the Use of the Optical Model for the Calculation of Neutron Cross Sections Below 20 MeV, Paris, 1985 (OECD/OCDE 1986) 75

- 1985IK1A K. Ikeda, H. Bando and T. Motoba, *Prog. Theor. Phys. Suppl.* 81 (1985) 147
- 1985JA16 N. Jarmie and R.E. Brown, *Nucl. Instrum. Meth. Phys. Res.* B10-11 (1985) 405
- 1985JA18 B.V. Jacak, D. Fox and G.D. Westfall, *Phys. Rev.* C31 (1985) 704
- 1985JE04 B. Jenny, W. Gruebler, V. Konig and P.A. Schmelzbach, *Nucl. Phys.* A444 (1985) 93
- 1985KA1D Kadkin, in *Leningrad* (1985) 297
- 1985KA1M M. Kaschiev, A.V. Matveenکو and J. Revai, *Phys. Lett.* B162 (1985) 18
- 1985KA20 H. Kanada, T. Kaneko, S. Saito and Y.C. Tang, *Nucl. Phys.* A444 (1985) 209
- 1985KH07 A.E. Khalil, *Phys. Rev.* C32 (1985) 1631
- 1985KO22 E.A. Kotikov and E.D. Makhnovsky, *Yad. Fiz.* 41 (1985) 289; *Sov. J. Nucl. Phys.* 41 (1985) 183
- 1985KO29 Yu.E. Kozyr, V.I. Medvedev, Yu.N. Pavlenko and V.M. Pugach, *Izv. Akad. Nauk SSSR, Ser. Fiz.* 49 (1985) 1026; *Bull. Acad. Sci. USSR Phys. Ser.* 49 (1985) 179
- 1985KR13 J.J. Kraushaar, P.D. Kunz, J.H. Mitchell, J.M. Cameron, D.A. Hutcheon, R.P. Liljestrاند, W.J. McDonald, C.A. Miller, W.C. Olsen, J.R. Tinsley et al., *Phys. Rev.* C32 (1985) 1083
- 1985KW02 E. Kwasniewicz and L. Jarczyk, *Nucl. Phys.* A441 (1985) 77
- 1985KW03 E. Kwasniewicz, J. Kisiel and L. Jarczyk, *Acta Phys. Pol.* B16 (1985) 947
- 1985LA20 I.A. Lantsev, V.I. Ostroumov, Yu.R. Gismatulin, V.N. Zbarag and A.A. Melentev, *Izv. Akad. Nauk SSSR Ser. Fiz.* 49 (1985) 143; *Bull. Acad. Sci. USSR Phys. Ser.* 49 (1985) 149
- 1985LE08 D.R. Lehman and W.C. Parke, *Phys. Rev.* C31 (1985) 1920; *Erratum Phys. Rev.* C37 (1988) 2266
- 1985LE1B Lemaire, *Int. Symp. Medium Energy Nucleon and Anti-Nucleon Scattering* (1985)
- 1985LI1C Y.-G. Ling, X. Zhao and F.-A. Zeng, *Phys. Energ. Fortis Phys. Nucl.* 9 (1985) 236
- 1985LI1F Y.-G. Ling and X. Zhao, *Chin. Phys.* 5 (1985) 77
- 1985LO02 M.A.K. Lodhi and K.E. Wald, *J. Phys. (London)* G11 (1985) 365
- 1985LO1A M.A. Lodhi and R.B. Hamilton, *Phys. Rev. Lett.* 54 (1985) 646
- 1985LU08 R.C. Luhn, S. Sen, N.O. Gaiser, S.E. Darden and Y. Koike, *Phys. Rev.* C32 (1985) 11
- 1985MA02 H. Machner, D. Protic, G. Riepe, H.G. Bohlen and H. Fuchs, *Phys. Rev.* C31 (1985) 443
- 1985MA13 M.T. Magda, A. Pop and A. Sandulescu, *J. Phys.* G11 (1985) L75
- 1985MA1G J.L. Matthews, *AIP Conf. Proc.* 133 (1985) 296
- 1985MAZG B.S. Mazitov and E.N. Rasulov, in *Leningrad* (1985) 298

- 1985MC05 B.J. McParland, E.G. Auld, P. Couvert, G.L. Giles, G. Jones, W. Ziegler, X. Aslanoglou, G.M. Huber, G.J. Lolos, S.I.H. Naqvi et al., Phys. Lett. B156 (1985) 47
- 1985ME02 A.C. Merchant and N. Rowley, Phys. Lett. B150 (1985) 35
- 1985MI05 S. Micek, Z. Majka, H. Rebel, H.J. Gils and H. Klewe-Nebenius, Nucl. Phys. A435 (1985) 621
- 1985MI10 R.E. Mischke, Nucl. Phys. A434 (1985) 505c
- 1985MI1E G. Michaud, AIP Conf. Proc. 126 (1985) 75
- 1985MI1F K. Miyagawa, Y. Koike, T. Ueda, T. Sawada and S. Takagi, Prog. Theor. Phys. 74 (1985) 1264
- 1985MO17 D.J. Morrissey, W. Benenson, E. Kashy, C. Bloch, M. Lowe, R.A. Blue, R.M. Ronningen, B. Sherrill, H. Utsunomiya and I. Kelson, Phys. Rev. C32 (1985) 877
- 1985MO1F T. Motoba, H. Bando, K. Ikeda and T. Yamada, Suppl. Prog. Theor. Phys. 81 (1985) 42
- 1985MO24 D.J. Morrissey, W. Benenson, E. Kashy, C. Bloch, M. Lowe, B. Sherrill, R.A. Blue, R.M. Ronningen and H. Utsunomiya, Nucl. Phys. A447 (1986) 603c
- 1985MOZZ A. Mondragon and E. Hernandez, Bull. Amer. Phys. Soc. 30 (1985) 700, AE4
- 1985NI01 K. Nisimura, H. Shimizu, K. Imai, T. Ichihara, N. Matsuoka, K. Hatanaka, H. Sakai, T. Saito, K. Hosono, M. Kondo et al., Nucl. Phys. A432 (1985) 378
- 1985NO1A Norbeck and Lin, Bull. Amer. Phys. Soc. 30 (1985) 1248
- 1985OS02 H. Oswald, M. Buballa, J. Helten, M. Karus, B. Laumann, R. Melzer, P. Niessen, G. Rauprich, J. Schulte-Uebbing, H. Paetz gen. Schieck and Y. Koike, Nucl. Phys. A435 (1985) 77
- 1985OS03 A. Osman and M.Y.H. Farag, Acta Phys. Pol. B16 (1985) 59
- 1985PA03 M.V. Pasechnik, L.S. Saltykov, E.P. Kadkin, I.I. Loshchakov and A.I. Vdovin, Izv. Akad. Nauk SSSR Ser. Fiz. 49 (1985) 53; Bull. Acad. Sci. USSR Phys. Ser. 49 (1985) 55
- 1985PA04 M.V. Pasechnik, L.S. Saltykov, E.P. Kadkin, I.I. Loshchakov and A.I. Vdovin, Izv. Akad. Nauk SSSR, Ser. Fiz. 49 (1985) 58; Bull. Acad. Sci. USSR Phys. Ser. 49 (1985) 61
- 1985PA1B Pasechnik, in Leningrad (1985) 265
- 1985PAZL M.V. Pasechnik, L.S. Saltykov, E.P. Kadkin, I.I. Loshchakov and A.I. Vdovin, in Leningrad (1985) 296
- 1985PO09 J. Pochodzalla, W.A. Friedman, C.K. Gelbke, W.G. Lynch, M. Maier, D. Ardouin, H. Delagrangé, H. Doubre, C. Gregoire, A. Kyanowski et al., Phys. Rev. Lett. 55 (1985) 177

- 1985PO10 N.A.F.M. Poppelier, L.D. Wood and P.W.M. Glaudemans, Phys. Lett. B157 (1985) 120
- 1985PU1B Pugach et al., in Leningrad (1985) 354
- 1985RE1A Repenko et al., in Leningrad (1985) 342
- 1985RE1B M.P. Rekalov, Sov. Phys. J. 28 (1985) 588
- 1985RO17 F. Roig and J. Navarro, Nucl. Phys. A440 (1985) 659
- 1985SA13 Y. Sakuragi, M. Kamimura, M. Yahiro and M. Tanifuji, Phys. Lett. B153 (1985) 372
- 1985SA1B Safronov, in Leningrad (1985) 407
- 1985SA1D Y. Sakuragi, M. Kamimura, M. Yahiro and Y. Fukushima, J. Phys. Soc. Jpn. 54 (1985) 88
- 1985SA32 H. Sato and Y. Okuhara, Phys. Lett. B162 (1985) 217
- 1985SA36 Y. Sakuragi, M. Kamimura, S. Micek, H. Rebel and H.J. Gils, Z. Phys. A322 (1985) 627
- 1985SC1A E. Schatzman, AIP Conf. Proc. 126 (1985) 69
- 1985SC1C Schramm, Nature 317 (1985) 386
- 1985SE17 M.R. Sene, I. Anthony, D. Branford, A.G. Flowers, A.C. Shotton and C.H. Zimmerman, Nucl. Phys. A442 (1985) 215
- 1985SH1A K.V. Shitikova, Fiz. Elem. Chastits At. Yadra 16 (1985) 824; Sov. J. Part. Nucl. 16 (1985) 364
- 1985SH1C J.R. Shepard, AIP Conf. Proc. 124 (1985) 107
- 1985SI12 B.K. Sinha, A.M. Nachabe, P. Bricault, J. Pouliot, L. Potvin, R. Roy and R.J. Slobodrian, Z. Phys. A321 (1985) 381
- 1985ST1A Stibunov, in Leningrad (1985) 341
- 1985ST1B R.G. Stokstad, Treatise on Heavy-Ion Sci. 3 (1985) 83
- 1985TA13 I. Tanihata, H. Hamagaki, O. Hashimoto, S. Nagamiya, Y. Shida, N. Yoshikawa, O. Yamakawa, K. Sugimoto, T. Kobayashi, D.E. Greiner et al., Phys. Lett. B160 (1985) 380
- 1985TA18 I. Tanihata, H. Hamagaki, O. Hashimoto, Y. Shida, N. Yoshikawa, K. Sugimoto, O. Yamakawa, T. Kobayashi and N. Takahashi, Phys. Rev. Lett. 55 (1985) 2676
- 1985TA1D I. Tanihata, Hyperfine Interactions 21 (1985) 251
- 1985VA1B C.D. Van Sice, J. Phys. G11 (1985) 267
- 1985VA1C Varlamov et al., in Leningrad (1985) 339
- 1985VI03 M.F. Vineyard, J. Cook and K.W. Kemper, Phys. Rev. C31 (1985) 879
- 1985WA1K T.P. Walker, G.J. Mathews and V.E. Viola, Astrophys. J. 299 (1985) 745

- 1985WA25 R.E. Warner, J.-Q. Yang, D.L. Friesel, P. Schwandt, G. Caskey, A. Galonsky, B. Remington, A. Nadasen, N.S. Chant, F. Khazaie et al., Nucl. Phys. A443 (1985) 64
- 1985WI1A Wieman et al., Bull. Amer. Phys. Soc. 30 (1985) 767
- 1985WO11 L.W. Woo, K. Kwiatkowski, S.H. Zhou and V.E. Viola, Phys. Rev. C32 (1985) 706
- 1985ZH1A X. Zhao, R.-C. Hou and F.-A. Zeng, Phys. Energ. Fortis Phys. Nucl. 9 (1985) 742
- 1985ZI05 W. Zickendraht, Ann. Phys. 42 (1985) 113
- 1985ZI1C V.G. Zinov, L.N. Somov and V.V. Fil'chenkov, Sov. At. Energy 58 (1985) 226
- 1986AH03 M.H. Ahsan and H.H. Thies, Nucl. Instrum. Meth. Phys. Res. A243 (1986) 523
- 1986AJ04 F. Ajzenberg-Selove, Nucl. Phys. A460 (1986) 1
- 1986AK1A A.I. Akhiezer and M.P. Rekalov, Dokl. Akad. Nauk SSSR 286 (1986) 613; Sov. Phys. Dokl. 31 (1986) 59
- 1986AK1B Akhiezer and Rekalov, Dopov. Akad. Nauk Ukr RSR A-FIZ. 12 (1986) 25
- 1986AK1C A.I. Akhiezer and M.P. Rekalov, Dokl. Akad. Nauk SSSR 287 (1986) 1365; Sov. Phys. Dokl. 31 (1986) 332
- 1986ALZJ W.P. Alford, AIP Conf. Proc. 150 (1986) 710
- 1986AN04 L.E. Antonuk, D. Bovet, E. Bovet, Y. De Coulon, J.-P. Egger, F. Goetz, P. Gretillat, C. Lunke, E. Schwarz, G.S. Adams et al., Nucl. Phys. A451 (1986) 741
- 1986AN26 B. Antolkovic, G. Paic and K. Kadija, Few-Body Syst. 1 (1986) 159
- 1986AS1A D. Ashery and J.P. Schiffer, Ann. Rev. Nucl. Part. Sci. 36 (1986) 207
- 1986AU1A V.E. Aushev, N.I. Zaika, Yu.V. Kibkalo, A.V. Mokhnach, G.G. Zaikin, A.A. Kluchnikov, A.A. Kozur, A.L. Taradanov, Yu.A. Chvanov and V.N. Scherbin, J. Phys. Soc. Jpn. Suppl. 55 (1986) 1074
- 1986AU1D N. Auerbach, AIP Conf. Proc. 150 (1986) 520
- 1986AV01 G.V. Avakov, L.D. Blokhintsev, A.M. Mukhamedzhanov and R. Yarmukhamedov, Yad. Fiz. 43 (1986) 824; Sov. J. Nucl. Phys. 43 (1986) 524
- 1986AV06 G.V. Avakov, B.F. Irgaziev and R. Yarmukhamedov, Yad. Fiz. 44 (1986) 942; Sov. J. Nucl. Phys. 44 (1986) 607
- 1986AV08 G.V. Avakov, L.D. Blokhintsev, T.D. Blokhintseva, V.P. Kurochkin and Zh.P. Pustynnik, Yad. Fiz. 44 (1986) 1471; Sov. J. Nucl. Phys. 44 (1986) 958
- 1986AV1B Avdeichikov, in Dubna (1986) 122
- 1986AZ01 I.G. Aznauryan and I.A. Troshenkova, Yad. Fiz. 43 (1986) 342; Sov. J. Nucl. Phys. 43 (1986) 219
- 1986BA1R G. Baur, C.A. Bertulani and H. Rebel, in Heidelberg (1986) 980
- 1986BA1W H. Bando, Nucl. Phys. A450 (1986) 217c

- 1986BA2G Barlamov, Ishkanov, Chernyaev and Eramzhian, in Kharkov (1986) 345
- 1986BA73 A.G. Baryshnikov, L.D. Blokhintsev, R. Kapote and D.A. Savin, *Izv. Akad. Nauk SSSR Ser. Fiz.* 50 (1986) 1962; *Bull. Acad. Sci. USSR Phys. Ser.* 50 (1986) 90
- 1986BA85 D.S. Bagdasaryan, E.M. Boyakhchyan, G.B. Kazaryan, M.D. Karibyan, E.R. Markaryan, G.G. Mkrtchyan and I.A. Troshenkova, *Izv. Akad. Nauk Arm. SSR Fiz.* 21 (1986) 284; *Sov. J. Contemp. Phys.* 21 (1986) 58
- 1986BE1L Bekbaev, Kim, Mazitov and Eramzhian, in Kharkov (1986) 436
- 1986BE35 A.V. Belozyorov, C. Borcea, Z. Dlouhy, A.M. Kalinin, R. Kalpakchieva, Nguyen Hoai Chau, Yu.Ts. Oganessian and Yu.E. Penionzhkevich, *Nucl. Phys.* A460 (1986) 352
- 1986BE44 A.V. Belozorov, K. Borchia, Z. Dlouhy, A.M. Kalinin, Nguen Khoai Tyau and Yu.E. Penionzhkevich, *Izv. Akad. Nauk SSSR Ser. Fiz.* 50 (1986) 1936; *Bull. Acad. Sci. USSR Phys. Ser.* 50 (1986) 64
- 1986BE45 Yu.A. Berezhnoi, A.V. Kuznichenko, G.M. Onishchenko and V.V. Pilipenko, *Izv. Akad. Nauk SSSR Ser. Fiz.* 50 (1986) 2050; *Bull. Acad. Sci. USSR Phys. Ser.* 50 (1986) 177
- 1986BO01 D.H. Boal and J.C. Shillcock, *Phys. Rev.* C33 (1986) 549
- 1986BO1E A.R. Bodmer and Q.N. Usmani, *Nucl. Phys.* A450 (1986) 257c
- 1986BR1N M. Bruno, F. Cannata, M.D. D'Agostino, M. Frisoni, H. Herman, B. Vuaridel, V. Konig, W. Gruebler, K. Elsener, P.A. Schemlzbach et al., *Few-Body Syst. Suppl.* 1 (1986) 211
- 1986BR20 R.E. Brown and N. Jarmie, *Radiat. Eff.* 92 (1986) 45
- 1986BR31 V.N. Bragin, N.T. Burtebaev, A.D. Dujsebaev, G.N. Ivanov, S.B. Sakuta, V.I. Chuev and L.V. Chulkov, *Yad. Fiz.* 44 (1986) 312; *Sov. J. Nucl. Phys.* 44 (1986) 198
- 1986BU07 V.V. Burov, V.M. Dubovik, S.G. Kadmsky, Yu.M. Tchuvilsky and L.A. Tosunyan, *J. Phys.* G12 (1986) 509
- 1986BY1A V.M. Bystritsky and J. Wozniak, *Acta Phys. Pol.* B17 (1986) 309
- 1986CE04 C. Cernigoi, N. Grion, G. Pauli, R. Rui and R. Cherubini, *Nucl. Phys.* A456 (1986) 599
- 1986CH10 C.B. Chitwood, C.K. Gelbke, J. Pochodzalla, Z. Chen, D.J. Fields, W.G. Lynch, R. Morse, M.B. Tsang, D.H. Boal and J.C. Shillcock, *Phys. Lett.* B172 (1986) 27
- 1986CH1I R.E. Chrien, *AIP Conf. Proc.* 150 (1986) 325
- 1986CH1J N.S. Chant, *AIP Conf. Proc.* 142 (1986) 246
- 1986CH1Q P. Chaumette, J. Deregél, G. Durand, J. Fabre, J. Movchet, L. van Rossum, J. Ball, V. Bouffard, G. Fournier and Y. Roinel, *Helv. Phys. Acta* 59 (1986) 767
- 1986CHZX C.T. Christou, D.R. Lehman and W.C. Parke, *Bull. Amer. Phys. Soc.* 31 (1986) 816, EI9

- 1986CL1B N.M. Clarke, P.J. Simmons, K.I. Pearce, S. Roman, A. Farooq and G. Rai, *J. Phys. Soc. Jpn. Suppl.* 55 (1986) 756
- 1986CL1C Clegg, *J. Phys. Soc. Jpn. Suppl.* 55 (1986) 535
- 1986CS1A L.P. Csernai and J.I. Kapusta, *Phys. Rept.* 131 (1986) 223
- 1986DA1B D.H. Davis and J. Pniewski, *Contemp. Phys.* 27 (1986) 91
- 1986DO11 T.W. Donnelly and A.S. Raskin, *Ann. Phys.* 169 (1986) 247
- 1986DO1K P. Doleschall, C. Chandler, M. Bruno, F. Cannata, M. D'Agostino and M.L. Fiantri, *Few-Body Syst. Suppl.* 1 (1986) 206
- 1986DU10 O. Dumbrajs, H. Heiselberg, A.S. Jensen, A. Miranda, G.C. Oades and J.M. Richard, *Nucl. Phys.* A457 (1986) 491
- 1986EL1A P.J. Ellis and Y.C. Tang, *Phys. Rev. Lett.* 56 (1986) 1309
- 1986EM02 V.G. Emelyanov, V.I. Klimov and V.N. Pomerantsev, *Izv. Akad. Nauk SSSR Ser. Fiz.* 50 (1986) 902; *Bull. Acad. Sci. USSR Phys. Ser.* 50 (1986) 70
- 1986EN05 R. Ent, H.P. Blok, J.F.A. van Hienen, G. van der Steenhoven, J.F.J. van den Brand, J.W.A. den Herder, E. Jans, P.H.M. Keizer, L. Lapikas, E.N.M. Quint et al., *Phys. Rev. Lett.* 57 (1986) 2367
- 1986EN1A Engelmann and Bardy, *Rept. CEA-R-5340* (1986)
- 1986EN1B Engelage et al., *Bull. Amer. Phys. Soc.* 31 (1986) 889
- 1986ER1A R.A. Eramzhyan, B.S. Ishkhanov, I.M. Kapitonov and V.G. Neudatchin, *Phys. Rept.* 136 (1986) 229
- 1986ESZY A. Eskandarian, D.R. Lehman and W.C. Parke, *Bull. Amer. Phys. Soc.* 31 (1986) 816, E18
- 1986EV1A Evseev, Buki, Likhachev and Shevchenko, in *Kharkov* (1986) 350
- 1986FI07 G.F. Filippov, V.S. Vasilevsky, S.P. Kruchinin and L.L. Chopovsky, *Yad. Fiz.* 43 (1986) 843; *Sov. J. Nucl. Phys.* 43 (1986) 536
- 1986FI15 B.W. Filippone, *Ann. Rev. Nucl. Part. Sci.* 36 (1986) 717
- 1986FI1A V.A. Filimonov, *Czech. J. Phys.* 36 (1986) 431
- 1986FI1D D. Fick, *J. Phys. Soc. Jpn. Suppl.* 55 (1986) 423
- 1986FL1A Flerov, in *Harrogate* (1986) *Suppl.* 1
- 1986FO04 D. Fox, D.A. Cebra, Z.M. Koenig, P. Ugorowski and G.D. Westfall, *Phys. Rev.* C33 (1986) 1540
- 1986FR12 V. Franco and Y. Yin, *Phys. Rev.* C34 (1986) 608
- 1986GA1F M. Gazdzicki, K. Iovchev, E. Kladnitskaya, E. Okonov and E.Z. Skrzypczak, *Z. Phys.* C31 (1986) 549
- 1986GE05 J.-F. Germond, *J. Phys. (London)* G12 (1986) 609

- 1986GL07 I.V. Glavanakov, V.N. Eponeshnikov, Yu.F. Krechetov, G.M. Radutsky and V.A. Tryasuchev, Phys. Lett. B178 (1986) 155
- 1986GL1A Glaudemans, AIP Conf. Proc. 142 (1986) 316
- 1986GLZU Yu.A. Glukhov, E.I. Koshchy, N.S. Lutsay, Yu.G. Mashkarov, E.Yu. Nikolsky, A.T. Rudchik, S.B. Sakuta and K.F. Ustimenkov, in Kharkov (1986) 371
- 1986GO1M B.I. Goryachev, Sov. J. Nucl. Phys. 44 (1986) 252
- 1986GO23 S.A. Goncharov, Yu.I. Denisov, A.M. Mukhamedzhanov, E.A. Romanovsky, G.E. Valiev, I.R. Gulamov, T. Iskhakov, G. Ni, N.K. Timofeyuk, R. Yarmukhamedov et al., Yad. Fiz. 44 (1986) 303; Sov. J. Nucl. Phys. 44 (1986) 191
- 1986GOZL J. Golden, Bull. Amer. Phys. Soc. 31 (1986) 890, KJ9
- 1986GR1A C. Gregoire and B. Tamain, Ann. Phys. (France) 11 (1986) 323
- 1986GR1D W. Gruebler, V. Konig, P.A. Schmelzbach, R.E. White, B. Vuaridel, C. Forstner, D. Singy, M. Bittcher and J. Ulbricht, J. Phys. Soc. Jpn. Suppl. 55 (1986) 884
- 1986GR1G Gridnev, Subbotin and Fadeev, in Dubna (1986) 114
- 1986HA1B B.G. Harvey, J. Phys. Colloq. (Paris) 47 (1986) C4-29
- 1986HA1L H. Hasan and B.K. Jain, Phys. Rev. C33 (1986) 1020
- 1986HA27 H.J. Hauser, M. Walz, F. Weng, G. Staudt and P.K. Rath, Nucl. Phys. A456 (1986) 253
- 1986HAZR L.F. Hansen, J. Rapaport, X. Wang and F.A. Barrios, Bull. Amer. Phys. Soc. 31 (1986) 1237, ED3
- 1986HU1B E.V. Hungerford, Nucl. Phys. A450 (1986) 157c
- 1986HU1D C.A. Hughes, S.D. Bloom and G.J. Mathews, Astrophys. J. 311 (1986) 485
- 1986IM01 O. Imambekov, Yu.N. Uzikov and L.V. Shevchenko, Yad. Fiz. 44 (1986) 1459; Sov. J. Nucl. Phys. 44 (1986) 950
- 1986IM1A Imambekov and Uzikov, in Kharkov (1986) 410
- 1986IO01 A.A. Ioannides and R.S. Mackintosh, Phys. Lett. B169 (1986) 113
- 1986JA02 L. Jarczyk, B. Kamys, Z. Rudy, A. Strzalkowski, B. Styczen, G.P.A. Berg, A. Magiera, J. Meissburger, W. Oelert, P. Von Rossen et al., Nucl. Phys. A448 (1986) 1
- 1986JA14 L. Jarczyk, B. Kamys, Z. Rudy, A. Strzalkowski, B. Styczen, G.P.A. Berg, A. Magiera, J. Meissburger, W. Oelert, P. von Rossen et al., Nucl. Phys. A459 (1986) 52
- 1986JA1E Jarime, Preprint LA-UR-86-3705 (1986)
- 1986JO1A R.C. Johnson, J. Phys. Soc. Jpn. Suppl. 55 (1986) 7

- 1986KA1B M. Kamimura, M. Yahiro, Y. Iseri, Y. Sakuragi, H. Kameyama and M. Kawai, Prog. Theor. Phys. Suppl. 89 (1986) 1
- 1986KA1C M. Kamimura, Y. Sakuragi, M. Yahiro and M. Tanifuji, J. Phys. Soc. Jpn. Suppl. 55 (1986) 205
- 1986KA1R Kailas and Gupta, in Santa Fe (1986) 1163
- 1986KA22 S. Kailas and S.K. Gupta, Phys. Rev. C34 (1986) 357
- 1986KA26 K. Kadija and G. Paic, Phys. Rev. C34 (1986) 380
- 1986KE1F Kerimov, Buras and El Gavkhari, in Kharkov (1986) 472
- 1986KI12 N.S.P. King, P.W. Lisowski, G.L. Morgan, P.N. Craig, R.G. Jeppesen, D.A. Lind, J.R. Shepard, J.L. Ullmann, C.D. Zafiratos, C.D. Goodman et al., Phys. Lett. B175 (1986) 279
- 1986KO1E H. Koch, AIP Conf. Proc. 150 (1986) 490
- 1986KO1J Y. Koike, J. Phys. Soc. Jpn. Suppl. 55 (1986) 272
- 1986KO1K H.-G. Korber, R. Beckmann, U. Holm and A. Lindner, J. Phys. Soc. Jpn. Suppl. 55 (1986) 632
- 1986KO1M V. Konig, P.A. Schmelzbach, W. Gruebler, Ch. Forstner, M. Bittcher, J. Ulbricht, B. Vuaridel and D. Singy, J. Phys. Soc. Jpn. Suppl. 55 (1986) 886
- 1986KO1N Korcheninnikov and Chulkov, in Kharkov (1986) 319
- 1986KO1U Kostin and Trubnikov, in Kharkov (1986) 422, 423
- 1986KR12 A.T. Kruppa, R.G. Lovas, R. Beck and F. Dickmann, Phys. Lett. B179 (1986) 317
- 1986KR1E A.T. Kruppa, in Heidelberg (1986) 57
- 1986KU08 V.I. Kukulín, V.M. Krasnopolsky, V.T. Voronchev and P.B. Sazonov, Nucl. Phys. A453 (1986) 365
- 1986KU1F Kukulín and Eramzhian, in Kharkov (1986) 146
- 1986LA22 K. Langanke, Nucl. Phys. A457 (1986) 351
- 1986LA27 K. Langanke and C. Rolfs, Z. Phys. A325 (1986) 193
- 1986LE21 D.R. Lehman and W.C. Parke, Few-Body Syst. 1 (1986) 193
- 1986LI1F Likhachev et al., in Kharkov (1986) 349
- 1986LIZP P.J. Lindstrom, M.E. Baumgartner, E. Beale, F. Bieser, M. Bronson, D.E. Greiner, C.P. McParland, D.L. Olson, H.J. Crawford, J. Engelage et al., Bull. Amer. Phys. Soc. 31 (1986) 888, KI5
- 1986MA19 J.F. Mateja, A.D. Frawley, L.C. Dennis and K. Sartor, Phys. Rev. C33 (1986) 1649
- 1986MA1C L. Majling, J. Zofka, V.N. Fetisov and R.A. Eramzhyan, Nucl. Phys. A450 (1986) 189c

- 1986MA1S G.S. Masson, T. Wise, P.A. Quin and W. Haeberli, Nucl. Instrum. Meth. Phys. Res. A242 (1986) 196
- 1986MA1V Magda, Pop and Sandulescu, in Harrogate (1986) C208
- 1986MA1X Mackintosh and Ioannides, in Harrogate (1986) A4, A5
- 1986MC11 B.J. McParland, E.G. Auld, P. Couvert, G.L. Giles, G. Jones, W. Ziegler, X. Aslanoglou, G.M. Huber, G.J. Lolos, S.I.H. Naqvi et al., Nucl. Phys. A456 (1986) 629
- 1986MCZZ M. McMaster, A. Judd, S. Villanueva, A. Nadasen, F.D. Becchetti, J. Janecke, P. Schwandt, J. Winfield, J. van der Plicht and R.E. Warner, Bull. Amer. Phys. Soc. 31 (1986) 839, GJ2
- 1986ME06 M.C. Mermaz, T. Suomijarvi, R. Lucas, B. Berthier, J. Matuszek, J.P. Coffin, G. Guillaume, B. Heusch, F. Jundt and F. Rami, Nucl. Phys. A456 (1986) 186
- 1986ME13 T. Mertelmeier and H.M. Hofmann, Nucl. Phys. A459 (1986) 387
- 1986MI1D K. Miyagawa, T. Ueda, T. Sawada and S. Takagi, J. Phys. Soc. Jpn. Suppl. 55 (1986) 686
- 1986MI1E K. Miyagawa, Y. Koike, T. Ueda, T. Sawada and S. Takagi, J. Phys. Soc. Jpn. Suppl. 55 (1986) 890
- 1986MI24 K. Mikulas, K.A. Gridnev, E.F. Hefter, V.M. Semjonov and V.B. Subbotin, Nuovo Cim. A93 (1986) 135
- 1986MO1E Z. Moroz, J. Phys. Soc. Jpn. Suppl. 55 (1986) 221
- 1986MOZQ A. Mondragon and E. Hernandez, in Harrogate (1986) B10, 36
- 1986OS07 A. Osman, Radiat. Eff. 95 (1986) 145
- 1986OS08 V.I. Ostroumov, I.I. Loshchakov and A.I. Vdovin, Izv. Akad. Nauk SSSR Ser. Fiz. 50, (1986) 916; Bull. Acad. Sci. USSR Phys. Ser. 50 (1986) 83
- 1986OS1D A. Osman, J. Phys. Soc. Jpn. Suppl. 55 (1986) 744
- 1986PE05 J.P. Perroud, A. Perrenoud, J.C. Alder, B. Gabioud, C. Joseph, J.F. Loude, N. Morel, M.T. Tran, E. Winkelmann, H. Von Fellenberg et al., Nucl. Phys. A453 (1986) 542
- 1986PF1A H.G. Pfutzner, A.L. Li, K. Murphy, C.R. Howell, M.L. Roberts, I. Slaus, R.L. Walter, M. Herman and H.M. Hofmann, J. Phys. Soc. Jpn. Suppl. 55 (1986) 556
- 1986PL01 R. Planeta, H. Klewe-Nebenius, J. Buschmann, H.J. Gils, H. Rebel, S. Zagromski, T. Kozik, L. Freindl and K. Grotowski, Nucl. Phys. A448 (1986) 110
- 1986PO1G O. Portilho, P.S.C. Alencar and S.A. Coon, Nucl. Phys. A450 (1986) 237c
- 1986PO1H B. Povh, Nucl. Phys. A450 (1986) 573c
- 1986POZX D. Pocanic, K. Wang, C.J. Martoff, S.S. Hanna, R.C. Byrd, C.C. Foster, D.L. Friesel, J. Rapaport and D. Wang, Bull. Amer. Phys. Soc. 31 (1986) 1216, BC15

- 1986RA02 J. Rama Rao, J. Ernst and H. Machner, Nucl. Phys. A448 (1986) 365
- 1986RA1C C. Rai, C. Blyth and A. Farooq, J. Phys. Soc. Jpn. Suppl. 55 (1986) 1010
- 1986RA1J G.M. Radutskii, Izv. Vyssh. Uch. Zav. Fiz. SSSR 29 (1986) 45; Sov. Phys. J. (USA) 29 (1986) 903
- 1986RE1C R. Rebolo, L. Crivellari, F. Castelli, B. Foing and J.E. Beckman, Astron. Astrophys. 166 (1986) 195
- 1986RE1D M.P. Rekaló, Ukr. Fiz. Zh. 31 (1986) 491
- 1986RI01 R. Rieder, P.D. Barnes, B. Bassalleck, R.A. Eisenstein, G. Franklin, R. Grace, C. Maher, P. Pile, J. Szymanski, W.R. Wharton et al., Phys. Rev. C33 (1986) 614
- 1986RO03 R. Rockmore and B. Saghai, Phys. Rev. C33 (1986) 576
- 1986RO27 M.S. Rowland and J.C. Robertson, Radiat. Eff. 96 (1986) 21
- 1986ROZK A. Roy, R.K. Bhowmik, C.V.K. Baba, M.G. Betigeri, R. Mythili and A.K. Jain, in Harrogate (1986) C225, 412
- 1986SA15 Y. Sakuragi, M. Kamimura, M. Yahiro and M. Tanifuji, Phys. Lett. B175 (1986) 105
- 1986SA1D Y. Sakuragi, M. Yahiro and M. Kamimura, Prog. Theor. Phys. Suppl. 89 (1986) 136
- 1986SA1K Y. Sakuragi, M. Kamimura, M. Yahiro and M. Tanifuji, J. Phys. Soc. Jpn. Suppl. 55 (1986) 770
- 1986SA1M J.A. Sawicki, J. Nucl. Mater. A141-143 (1986) 327
- 1986SA1N Y. Sakuragi, Rept. Joint Seminar on Heavy-Ion Nucl. Phys. Nucl. Chem. in the Energy Region of Tandem Accelerators (II), Apr. 1986, Tokai, Ibaraki, Japan (1986) 70
- 1986SA1Q H. Sakai, N. Matsuoka, T. Saito and A. Shimizu, J. Phys. Soc. Jpn. Suppl. 55 (1986) 1112
- 1986SA30 H. Sato and Y. Okuhara, Phys. Rev. C34 (1986) 2171
- 1986SAZJ Y. Sakuragi, in Harrogate (1986) 275
- 1986SAZK Y. Sakuragi, in Harrogate (1986) 274
- 1986SAZL Y. Sakuragi, in Harrogate (1986) 273
- 1986SAZS D.P. Sanderson and K.W. Kemper, Bull. Amer. Phys. Soc. 31 (1986) 1204, AB2
- 1986SC28 C.J.S. Scholz, L. Ricken and E. Kuhlmann, Z. Phys. A325 (1986) 203
- 1986SH14 K. Shoda, M. Torikoshi, O. Sasaki, S. Toyama, T. Kobayashi, A. Kagaya and H. Tsubota, Phys. Rev. C33 (1986) 2179
- 1986SHZP T. Shimoda, N. Ikeda, A. Nakamura, S. Shimoura, K. Katori, T. Fukuda and H. Ogata, in Harrogate (1986) C159, 346
- 1986SIZS P.J. Simmonds, N.M. Clarke, K.I. Pearce, R.J. Griffiths, C.A. Ogilvie and M. Mannon, in Harrogate (1986) C128, 315

- 1986SR02 D.K. Srivastava and H. Rebel, J. Phys. (London) G12 (1986) 717
- 1986ST1E E. Steffens, J. Phys. Soc. Jpn. Suppl. 55 (1986) 459
- 1986SU1K C.-S. Su, Nucl. Tracks Radiat. Meas. 12 (1986) 325
- 1986SY1A T.J.M. Symons, Nucl. Phys. A447 (1986) 157c
- 1986SZ1A J.J. Szymanski, AIP Conf. Proc. 150 (1986) 934
- 1986TA06 H. Taneichi, H. Ueno, K. Shoda, Y. Kawazoe and T. Tsukamoto, Nucl. Phys. A448 (1986) 315
- 1986TA1E T.N. Taddeucci, J. Phys. Soc. Jpn. Suppl. 55 (1986) 156
- 1986TA1G M. Tanifuji, M. Kamimura and Y. Sakuragi, J. Phys. Soc. Jpn. Suppl. 55 (1986) 198
- 1986TA1M B. Tamain, Proc. Int. Nucl. Phys. Conf., Harrogate, U.K., No. 68, Vol. 2 (1986) 247
- 1986VA13 V.S. Vasilevsky, G.F. Fillipov, L.L. Chopovsky and S.P. Kruchinin, Izv. Akad. Nauk SSSR Ser. Fiz. 50 (1986) 151; Bull. Acad. Sci. USSR Phys. Ser. 50 (1986) 148
- 1986VL1A Vladimirov and Gaponov, in Kharkov (1986) 196
- 1986VO09 V.T. Voronchev, V.I. Kukulín, V.M. Krasnopol'sky and P.B. Sazonov, Yad. Fiz. 43 (1986) 1149; Sov. J. Nucl. Phys. 43 (1986) 735
- 1986VU1B B. Vuaridel, V. König, W. Gruebler, K. Elsener, P.A. Schmelzbach, J. Ulbricht, C. Forstner, M. Bittcher, D. Singy, M. Bruno et al., J. Phys. Soc. Jpn. Suppl. 55 (1986) 874
- 1986VUZZ B. Vuaridel, W. Gruebler, V. König, P.A. Schmelzbach, K. Elsener, J. Ulbricht, D. Singy, Ch. Forstner, M. Bittcher, M. Bruno et al., in Harrogate (1986) 258, C71
- 1986WA11 R.E. Warner, B.A. Vaughan, D.L. Friesel, P. Schwandt, J.-Q. Yang, G. Caskey, A. Galonsky, B. Remington and A. Nadasen, Nucl. Phys. A453 (1986) 605
- 1986WA1J X.-C. Wang, H. Takaki and H. Bando, Prog. Theor. Phys. 76 (1986) 865
- 1986WE1C G.D. Westfall, Nucl. Phys. A447 (1986) 591c
- 1986WH01 W.R. Wharton, P.D. Barnes, B. Bassalleck, R.A. Eisenstein, G. Franklin, R. Grace, C. Maher, P. Pile, R. Rieder, J. Szymanski et al., Phys. Rev. C33 (1986) 1435
- 1986WI04 D.H. Wilkinson, Nucl. Phys. A452 (1986) 296
- 1986WI1A Wilmerding, Maglich, Nering and Powell, Bull. Amer. Phys. Soc. 31 (1986) 890
- 1986XU1B H.M. Xu and W.G. Lynch, Int. Conf. on Nucl. Radiochem, 1-5 Sept. 1986, Beijing, China (1986) 54
- 1986YA12 T. Yamaya, J.I. Hirota, K. Takimoto, S. Shimoura, A. Sakaguchi, S. Kubono, M. Sugitani, S. Kato, T. Suehiro and M. Fukada, Phys. Rev. C34 (1986) 2369
- 1986YA1L Yamagata et al., in Harrogate (1986) B63
- 1986YO06 H. Yokota, K. Nakayama, K. Ichimaru, T. Katsumi, T. Mori, S. Igarashi, K. Hama, R. Chiba, K. Nakai, J. Chiba et al., Phys. Rev. Lett. 57 (1986) 807

- 1986ZA1C Zaritskii et al., in Kharkov (1986) 401
- 1986ZE01 N.S. Zelenskaya and A.K. Morzabaev, *Yad. Fiz.* 43 (1986) 879; *Sov. J. Nucl. Phys.* 43 (1986) 559
- 1986ZH03 M.A. Zhusupov, O. Imambekov and Yu.N. Uzikov, *Izv. Akad. Nauk SSSR Ser. Fiz.* 50 (1986) 178; *Bull. Acad. Sci. USSR Phys. Ser.* 50 (1986) 172
- 1986ZH1B F. Zhuang and H.Z. Chen, *Chin. J. Nucl. Phys.* 8 (1986) 325
- 1986ZO1A J. Zofka, *Nucl. Phys.* A450 (1986) 165c
- 1987AB09 S.N. Abramovich, L.A. Morkin, V.I. Serov and Yu.V. Strelnikov, *Izv. Akad. Nauk SSSR Ser. Fiz.* 51 (1987) 930; *Bull. Acad. Sci. USSR Phys. Ser.* 51 (1987) 92
- 1987AJ02 F. Ajzenberg-Selove, *Nucl. Phys.* A475 (1987) 1
- 1987AJ1A F. Ajzenberg-Selove, in Dubna (1987) 341
- 1987AL1C C. Alcock, G.M. Fuller and G.J. Mathews, *Astrophys. J.* 320 (1987) 439
- 1987AL23 D.V. Aleksandrov, Yu.A. Glukhov, B.G. Novatsky, E.Yu. Nikolsky, S.B. Sakuta and D.N. Stepanov, *Yad. Fiz.* 46 (1987) 385; *Sov. J. Nucl. Phys.* 46 (1987) 197
- 1987AR13 A.E. Aravantinos and A.C. Xenoulis, *Phys. Rev.* C35 (1987) 1746
- 1987AR19 S.E. Arnell, S. Mattsson, H.A. Roth, M. Rydehell, O. Skeppstedt, A. Johnson, J. Nyberg, A. Kerek and A. Nilsson, *Phys. Scr.* 36 (1987) 214
- 1987AR1C Arnould, *Phil. Trans. Roy. Soc. (London)* 323 (1987) 251
- 1987AR1J K. Arai, M. Hasimoto and T. Fukui, *Astron. Astrophys.* 179 (1987) 17
- 1987AS05 H.J. Assenbaum, K. Langanke and C. Rolfs, *Z. Phys.* A327 (1987) 461
- 1987AS06 E. Aslanides, D.M. Drake, J.C. Peng, D. Garreta, P. Birien, G. Bruge, H. Catz, A. Chaumeaux, S. Janouin, D. LeGrand et al., *Nucl. Phys.* A470 (1987) 445
- 1987AU1A J. Audouze, *J. Astrophys. Astron.* 8 (1987) 147
- 1987AU1C Auchev et al., in Yurmala (1987) 395
- 1987BA13 J. Banaigs, J. Berger, P. Berthet, G. Bizard, M. Boivin, M. De Sanctis, J. Duflo, F.L. Fabbri, R. Frascaria, L. Goldzahl et al., *Phys. Rev.* C35 (1987) 1416
- 1987BA1I B.F. Bayman and Y.C. Tang, *Phys. Rept.* 147 (1987) 155
- 1987BA2C Barlanov, Surgutanov and Chernyaev, in Yurmala (1987) 371
- 1987BA38 G.J. Balster, P.C.N. Crouzen, P.B. Goldhoorn, R.H. Siemssen and H.W. Wilschut, *Nucl. Phys.* A468 (1987) 93
- 1987BA39 G.J. Balster, H.W. Wilschut, R.H. Siemssen, P.C.N. Crouzen, P.B. Goldhoorn and Z. Sujkowski, *Nucl. Phys.* A468 (1987) 131
- 1987BE2A A.S. Belousov, Ya.A. Vazdik, E.I. Malinovskii, S.V. Rusakov, P.A. Smirnov, Yu.V. Solov'ev, A.P. Usik, A.R. Terkulov and A.M. Fomenko, *Sov. Phys. Lebedev Inst. Rept.* 2 (1987) 13

- 1987BE45 J.J. Bevelacqua, *Indian J. Phys.* A61 (1987) 111
- 1987BEYI A.V. Belozyorov, C. Borcea, Z. Dlouhy, A.M. Kalinin, Nguyen Hoai Chau and Yu.E. Penionzhkevich, *JINR-E15-87-733* (1987)
- 1987BL13 C. Bloch, W. Bensenon, A.I. Galonsky, E. Kashy, J. Heltsley, L. Heilbronn, M. Lowe, B. Remington, D.J. Morrissey and J. Kasagi, *Phys. Rev.* C36 (1987) 203
- 1987BL18 R. Blumel and K. Dietrich, *Nucl. Phys.* A471 (1987) 453
- 1987BL1K L.D. Blokhintsev, Kh.D. Razikov, M.K. Ubaidullaeva and R. Yarmukhamedov, *Izv. Akad. Nauk. SSSR Ser. Fiz.* 51 (1987) 189; *Bull. Acad. Sci. USSR Phys. Ser.* 51 (1987) 173
- 1987BO1L A.R. Bodmer and Q.N. Usmani, *Nucl. Phys.* A463 (1987) 221c
- 1987BO1O A.R. Bodmer and Q.N. Usmani, *Nucl. Phys.* A468 (1987) 653
- 1987BO1P E.T. Boschitz, W. Gyles, K. Junker, W. List, C.R. Ottermann and R. Tacik, *SIN Newsl. (Switzerland)* 19 (1987) 42
- 1987BO39 O.V. Bochkarev, A.A. Korshennikov, E.A. Kuzmin, I.G. Mukha, A.A. Ogloblin, L.V. Chulkov and G.B. Yankov, *Yad. Fiz.* 46 (1987) 12; *Sov. J. Nucl. Phys.* 46 (1987) 7
- 1987BO40 C. Borcea, A.V. Belozyorov, Z. Dlouhy, A.M. Kalinin, Nguyen Hoai Chau and Yu.E. Penionzhkevich, *Rev. Roum. Phys.* 32 (1987) 497
- 1987BR02 R.E. Brown, F.D. Correll, P.M. Hegland, J.A. Koepke and C.H. Poppe, *Phys. Rev.* C35 (1987) 383
- 1987BR07 M. Bruno, F. Cannata, M. D'Agostino, M.L. Fiandri, M. Frisoni, H. Oswald, P. Niessen, J. Schulte-Uebbing, H. Paetz gen. Schieck, P. Doleschall et al., *Phys. Rev.* C35 (1987) 1563
- 1987BR1V W.H. Breunlich, M. Cagnelli, P. Kammel, J. Marton, N. Naegele, J. Werner, J. Zmeskal, C. Petitjean, J. Bistirlich, K. Crowe et al., *Muon Catal. Fusion (Switzerland)* 1 (1987) 121
- 1987BR32 F.P. Brady, *Can. J. Phys.* 65 (1987) 578
- 1987BU04 N.A. Burkova and M.A. Zhusupov, *Izv. Akad. Nauk SSSR Ser. Fiz.* 51 (1987) 182; *Bull. Acad. Sci. USSR Phys. Ser.* 51 (1987) 167
- 1987BU20 N.A. Burgov, A.E. Buklei, M.K. Vlasov, L.S. Vorobev, S.A. Gerzon, Yu.T. Kiselev, G.A. Leksin, A.N. Martemyanov, V.L. Novikov, N.A. Pivnyuk et al., *Yad. Fiz.* 45 (1987) 743; *Sov. J. Nucl. Phys.* 45 (1987) 463
- 1987BU27 N.T. Burtebaev, A.D. Duisebaev, V.S. Sadkovskii and G.A. Feofilov, *Izv. Akad. Nauk SSSR Ser. Fiz.* 51 (1987) 615; *Bull. Acad. Sci. USSR Phys. Ser.* 51 (1987) 191
- 1987CH08 Z. Chen, C.K. Gelbke, J. Pochodzalla, C.B. Chitwood, D.J. Fields, W.G. Lynch and M.B. Tsang, *Phys. Lett.* B186 (1987) 280

- 1987CH10 R.E. Chrien, E.V. Hungerford and T. Kishimoto, Phys. Rev. C35 (1987) 1589
- 1987CH26 Z. Chen, C.K. Gelbke, J. Pochodzalla, C.B. Chitwood, D.J. Fields, W.G. Gong, W.G. Lynch and M.B. Tsang, Nucl. Phys. A473 (1987) 564
- 1987CH32 Z. Chen, C.K. Gelbke, W.G. Gong, Y.D. Kim, W.G. Lynch, M.R. Maier, J. Pochodzalla, M.B. Tsang, F. Saint-Laurent, D. Ardouin et al., Phys. Lett. B199 (1987) 171
- 1987CH33 Z. Chen, C.K. Gelbke, W.G. Gong, Y.D. Kim, W.G. Lynch, M.R. Maier, J. Pochodzalla, M.B. Tsang, F. Saint-Laurent, D. Ardouin et al., Phys. Rev. C36 (1987) 2297
- 1987CO1S Coon, Bull. Amer. Phys. Soc. 32 (1987) 1549
- 1987DA1G Danilin et al., in Yurmala (1987) 200
- 1987DA1H Danilin et al., in Yurmala (1987) 467
- 1987DA31 B.V. Danilin, M.V. Zhukov, A.A. Korshennikov, L.V. Chulkov and V.D. Efros, Yad. Fiz. 46 (1987) 427; Sov. J. Nucl. Phys. 46 (1987) 225
- 1987DE02 A.C. Demijanov, V.N. Bragin, A.A. Ogloblin, A.L. Lebedev, J.M. Bang, S.A. Goncharov, S.N. Ershov, F.A. Gareev and P.P. Korovin, Phys. Lett. B184 (1987) 129
- 1987DE37 F. Deak, A. Kiss, Z. Seres, G. Caskey, A. Galonsky and B. Remington, Nucl. Instrum. Meth. Phys. Res. A258 (1987) 67
- 1987DE43 H. De Vries, C.W. De Jager and C. De Vries, At. Data Nucl. Data Tables 36 (1987) 495
- 1987DO07 G. Domogala, H. Freiesleben and B. Hippert, Nucl. Instrum. Meth. Phys. Res. A257 (1987) 7
- 1987DO13 K.G.R. Doss, H.-A. Gustafsson, H. Gutbrod, J.W. Harris, B.V. Jacak, K.-H. Kampert, B. Kolb, A.M. Poskanzer, H.-G. Ritter, H.R. Schmidt et al., Phys. Rev. Lett. 59 (1987) 2720
- 1987DU07 J. Duffo, Phys. Rev. C36 (1987) 1425
- 1987DU09 E.I. Dubovoi and G.I. Chitanava, Yad. Fiz. 45 (1987) 677; Sov. J. Nucl. Phys. 45 (1987) 423
- 1987DZ1B R.I. Dzhibuti, T.Ya. Mikhelashvili and K.V. Shitikova, Yad. Fiz. 45 (1986) 670; Sov. J. Nucl. Phys. 45 (1987) 419
- 1987EY01 W. Eyrich, A. Hofmann, A. Lehmann, B. Muhlendorfer, H. Schlosser, H. Wirth, H.J. Gils, H. Rebel and S. Zagromski, Phys. Rev. C36 (1987) 416
- 1987FA01 M. Fatyga, H.J. Karwowski, K. Kwiatkowski, L. Nowicki, V.E. Viola and K. Hicks, Phys. Rev. C35 (1987) 568
- 1987FA02 A. Fahli, J.P. Coffin, G. Guillaume, B. Heusch, F. Jundt, F. Rami, P. Wagner, P. Fintz, A.J. Cole, S. Kox et al., Z. Phys. A326 (1987) 169
- 1987FA1H G. Faldt, C. Lazard and R.J. Lombard, Phys. Rev. C36 (1987) 1037

- 1987FE1A E.-P. Feng, Q. Wang, Y.-T. Zhu, X. Yin, H.-B. Miao, S.-M. Sun, S.-L. Li, Z.-L. Wu, G.-Y. Fan, Y.-X. Xie et al., *Chin. Phys.* 7 (1987) 121
- 1987FI1D D. Fick, *Phys. Bl. (West Germany)* 43 (1987) 446
- 1987FO08 D. Fox, D.A. Cebra, J. Karn, C. Parks, G.D. Westfall and W.K. Wilson, *Phys. Rev. C* 36 (1987) 640
- 1987FR1G W.A. Friedman, *Nucl. Phys.* A471 (1987) 327c
- 1987GA20 A.K. Ganguly, B. Chaudhuri and B.B. Baliga, *Nuovo Cim.* A97 (1987) 639
- 1987GA22 V.B. Ganenko, V.A. Gushchin, Yu.V. Zhebrowsky, L.Ya. Kolesnikov, A.L. Rubashkin and P.V. Sorokin, *Pisma Zh. Eksp. Teor. Fiz.* 46 (1987) 216; *JETP Lett. (USSR)* 46 (1987) 272
- 1987GAZM S.A. Gaidaenko, E.P. Kadkin, M.V. Pasechnik, L.S. Saltykov and A.D. Fursa, in *Yurmala* (1987) 299
- 1987GAZZ N.O. Gaiser, S.E. Darden, R.C. Luhn, H. Paetz gen. Schieck and S. Sen, *Bull. Amer. Phys. Soc.* 32 (1987) 1059, EE14
- 1987GE1B C.-K. Gelbke and D.H. Boal, *Prog. Part. Nucl. Phys.* 19 (1987) 33
- 1987GL01 I.V. Glavanakov, A.L. Deynezhenko, V.N. Eponeshnikov, Yu.F. Krechetov, G.A. Pleshkov, G.M. Radutsky, G.A. Saruev, A.A. Sidorov, V.A. Tryasuchev and E.N. Shuvalov, *Yad. Fiz.* 45 (1987) 3; *Sov. J. Nucl. Phys.* 45 (1987) 1; Erratum *Sov. J. Nucl. Phys.* 46 (1987) 384
- 1987GL05 Yu.A. Glukhov, A.S. Demyanova, A.A. Ogloblin and S.B. Sakuta, *Yad. Fiz.* 45 (1987) 1236; *Sov. J. Nucl. Phys.* 45 (1987) 767
- 1987GLZW Yu.A. Glukhov, S.B. Sakuta and D.N. Stepanov, in *Yurmala* (1987) 383
- 1987GM02 M. Gmitro, S.S. Kamalov and R. Mach, *Phys. Rev. C* 36 (1987) 1105
- 1987GM04 M. Gmitro, S. Kamalov and R. Mach, *Prog. Theor. Phys. (Kyoto) Suppl.* 91 (1987) 60
- 1987GO1S Goryunov et al., in *Yurmala* (1987) 474
- 1987GO27 S.A. Goncharov, A.M. Mukhamedzhanov, E.A. Romanovsky, G.E. Valiev, I.R. Gulamov, T. Iskhakov, G. Nie, N.K. Tomopheyyuk, R. Yarmukhamedov, V. Kroha et al., *Czech. J. Phys.* B37 (1987) 168
- 1987GOZN M.G. Gornov, P.V. Morokhov, V.A. Pechkurov, F.M. Sergeev, A.A. Khomutov and R.R. Shafigullin, in *Yurmala* (1987) 269
- 1987GR08 W. Gruebler, *Nucl. Phys.* A463 (1987) 193c
- 1987GR11 R.E.L. Green, R.G. Korteling, J.M. D'Auria, K.P. Jackson and R.L. Helmer, *Phys. Rev. C* 35 (1987) 1341
- 1987GR1I A.M. Green and J.A. Niskanen, *Prog. Part. Nucl. Phys.* 18 (1987) 93
- 1987GR1N Gridnev, Subbotin and Fadeev, in *Yurmala* (1987) 426

- 1987GU1L Gusev and Seliverstov, in Dubna (1987) 217
- 1987GUZZ I.R. Gulamov, T. Iskhakov, A.M. Mukhamedzhanov, Sh. Kayumov, A.A. Karakhodzhaev, G.K. Ni, E.A. Romanovsky and G.S. Valiev, in Yurmala (1987) 344
- 1987HA01 Y. Haneishi and T. Fujita, Phys. Rev. C35 (1987) 70
- 1987HA30 P.G. Hansen and B. Jonson, Europhys. Lett. 4 (1987) 409
- 1987HA34 K. Hahn, Phys. Rev. C36 (1987) 1692
- 1987HA40 R. Hausmann, P.B. Siegel, W. Weise and M. Kohno, Phys. Lett. B199 (1987) 17
- 1987HA45 D. Hahn and H. Stocker, Phys. Rev. C35 (1987) 1311
- 1987HE22 R. Helmer, Can. J. Phys. 65 (1987) 588
- 1987HO1M L.M. Hobbs and D.K. Duncan, Astrophys. J. 317 (1987) 796
- 1987HU02 J.R. Hurd, J.S. Boswell, R.C. Minehart, L.B. Rees, Y. Tzeng, H.J. Ziock and K.O.H. Ziock, Nucl. Phys. A462 (1987) 605
- 1987HU13 J.R. Hurd, J.S. Boswell, R.C. Minehart, Y. Tzeng, H.J. Ziock, K.O.H. Ziock, L.C. Liu and E.R. Siciliano, Nucl. Phys. A475 (1987) 743
- 1987IM04 O. Imambekov and Yu.N. Uzikov, Izv. Akad. Nauk SSSR Ser. Fiz. 51 (1987) 947; Bull. Acad. Sci. USSR Phys. Ser. 51 (1987) 107
- 1987IM1F Imambekov, Uzikov and Zhusupov, in Panic (1987) 276
- 1987JA06 B.V. Jacak, G.D. Westfall, G.M. Crawley, D. Fox, C.K. Gelbke, L.H. Harwood, B.E. Hasselquist, W.G. Lynch, D.K. Scott, H. Stocker et al., Phys. Rev. C35 (1987) 1751
- 1987JA1C B.K. Jain and S.K. Gupta, Z. Phys. A326 (1987) 191
- 1987JE03 H. Jelitto, H.J. Gils, H. Rebel and S. Zagromski, Rev. Roum. Phys. 32 (1987) 629
- 1987JI1A G.-Y. Jiang and X.-N. Jin, Phys. Energ. Fortis Phys. Nucl. 11 (1987) 226
- 1987KA1I M. Kamimura, Y. Sakuragi, Y. Iseri, M. Yahiro, H. Kameyama, M. Kawai and M. Tanifuji, INS-REP.-606 (1987)
- 1987KA1L Kadmenskii et al., in Yurmala (1987) 473
- 1987KA1M Karmanov et al., in Yurmala (1987) 509
- 1987KI1C H.R. Kissener, I. Rotter and N.G. Goncharova, Fortschr. Phys. 35 (1987) 277
- 1987KO15 T. Kozik, J. Buschmann, K. Grotowski, H.J. Gils, N. Heide, J. Kiener, H. Klewe-Nebenius, H. Rebel, S. Zagromski, A.J. Cole et al., Z. Phys. A326 (1987) 421
- 1987KO1L Kozmyr and Sokolov, in Yurmala (1987) 331
- 1987KO1Z Kobayashi et al., in Panic (1987) 478
- 1987KO39 A.A. Korshennikov and L.V. Chulkov, Izv. Akad. Nauk SSSR Ser. Fiz. 51 (1987) 124; Bull. Acad. Sci. USSR Phys. Ser. 51 (1987) 116
- 1987KR07 A.T. Kruppa, R. Beck and F. Dickmann, Phys. Rev. C36 (1987) 327

- 1987KR09 A. Krauss, H.W. Becker, H.P. Trautvetter and C. Rolfs, Nucl. Phys. A467 (1987) 273
- 1987KU1G Kuznetzova, Krasnopolskii and Kukulín, in Yurmala (1987) 500
- 1987KU23 Y. Kuno, K. Nagamine and T. Yamazaki, Nucl. Phys. A475 (1987) 615
- 1987KUZl V.l. Kukulín, in Yurmala (1987) 151
- 1987KW01 E. Kwasniewicz and J. Kisiel, J. Phys. G13 (1987) 121
- 1987KW03 E. Kwasniewicz and J. Kisiel, Rev. Roum. Phys. 32 (1987) 607
- 1987LA1J A. Lamberty, E. Michels and P. De Bievre, Int. J. Mass Spectrom. Ion Proc. 79 (1987) 311
- 1987LA25 M. Lattuada, F. Riggi, D. Vinciguerra, C. Spitaleri and D. Miljanic, Z. Phys. A328 (1987) 497
- 1987LE1B F. Lenz, Prog. Theor. Phys. Suppl. 91 (1987) 27
- 1987LE1C Lehman, Bull. Amer. Phys. Soc. 32 (1987) 1025
- 1987LE1E Leisi et al., Helv. Phys. Acta. 60 (1987) 316
- 1987LE33 F.S. Levin, Nucl. Phys. A463 (1987) 487c
- 1987LI32 V.P. Likhachev, I.G. Evseev, A.Yu. Buki, Yu.V. Vladimirov, S.A. Pashchuk, G.A. Savitsky, V.M. Khvastunov, V.A. Fartushny, V.B. Shostak and V.A. Stepanenko, Ukr. Fiz. Zh. 32 (1987) 1293
- 1987LO16 R.G. Lovas, A.T. Kruppa, R. Beck and F. Dickmann, Nucl. Phys. A474 (1987) 451
- 1987LU1B Lubovoi and Chitanava, in Yurmala (1987) 512
- 1987LY04 W.G. Lynch, Nucl. Phys. A471 (1987) 309c
- 1987LY1D W.G. Lynch, Ann. Rev. Nucl. Part. Sci. 37 (1987) 493
- 1987MA1I Matthews et al., in Panic (1987) 360
- 1987MA2C Malaney and Fowler, OAP-680, To be published in Origin and Distribution of the Elements (1987)
- 1987MI06 K. Miyagawa, T. Ueda, T. Sawada and S. Takagi, Nucl. Phys. A463 (1987) 411c
- 1987MO1I A. Mondragon and E. Hernandez, 6th Int. Symp. on Capture Gamma-ray Spectroscopy, 31 Aug.-4 Sept. 1987, Leuven, Belgium (1988) 794
- 1987NA01 M.N. Namboodiri, R.K. Choudhury, L. Adler, J.D. Bronson, D. Fabris, U. Garg, P.L. Gonthier, K. Hagel, D.R. Haenni, Y.W. Lui et al., Phys. Rev. C35 (1987) 149
- 1987NA04 J. Navarro and F. Roig, Nucl. Phys. A465 (1987) 628
- 1987NA1I Naumenko et al., in Yurmala (1987) 370
- 1987NI04 W. Nitsche, G.J. Wagner, K.T. Knopfle, P. Grabmayr and Y. Kawazoe, Z. Phys. A326 (1987) 435
- 1987PA12 S.J. Padalino, K. Sartor, L.C. Dennis and K.W. Kemper, Phys. Rev. C35 (1987) 1692

- 1987PA1F R. Pallavicini, M. Cerruti-Sola and D.K. Duncan, *Astron. Astrophys.* 174 (1987) 116
- 1987PE1C Penionshkevich, in *Dubna* (1987) 364
- 1987PI06 I.M. Piskarev, *Yad. Fiz.* 45 (1987) 1222; *Sov. J. Nucl. Phys.* 45 (1987) 758
- 1987PO03 J. Pochodzalla, C.K. Gelbke, W.G. Lynch, M. Maier, D. Ardouin, H. Delagrangé, H. Doubre, C. Gregoire, A. Kyanowski, W. Mittig et al., *Phys. Rev. C* 35 (1987) 1695
- 1987PO05 H. Poth, H. Barth, G. Buche, A.D. Hancock, H. Koch, Th. Kohler, A. Kreissl, U. Raich, D. Rohmann, A. Wolf et al., *Nucl. Phys. A* 466 (1987) 667
- 1987PO18 D. Pocanic, K. Wang, C.J. Martoff, S.S. Hanna, R.C. Byrd, C.C. Foster, D.L. Friesel and J. Rapaport, *Can. J. Phys.* 65 (1987) 687
- 1987PO1H B. Povh, *Prog. Part. Nucl. Phys.* 18 (1987) 183
- 1987PO1M L.I. Ponomarev and G. Fiorentini, *Muon Catalyzed Fusion* 1 (1987) 3
- 1987PO23 J. Pochodzalla, *Nucl. Phys. A* 471 (1987) 289c
- 1987PR08 S. Pratt and M.B. Tsang, *Phys. Rev. C* 36 (1987) 2390
- 1987RA1I Ransome et al., *Bull. Amer. Phys. Soc.* 32 (1987) 1560
- 1987RA32 J. Rapaport, *Can. J. Phys.* 65 (1987) 574
- 1987RO10 G. Royer, Y. Raffray, A. Oubahadou and B. Remaud, *Nucl. Phys. A* 466 (1987) 139
- 1987RO25 C. Rolfs, H.P. Trautvetter and W.S. Rodney, *Rep. Prog. Phys.* 50 (1987) 233
- 1987SA15 H. Sagawa and H. Toki, *J. Phys. G* 13 (1987) 453
- 1987SA1C Sakuragi, Yahiro and Kamimura, *INS-REP.-600* (1986)
- 1987SA21 Y. Sakuragi, *Phys. Rev. C* 35 (1987) 2161
- 1987SA46 H. Sakai, N. Matsuoka, T. Noro, T. Saito, A. Shimizu, M. Tosaki, M. Ieiri, K. Imai, A. Sakaguchi, Y. Takeuchi et al., *Nucl. Instrum. Meth. Phys. Res. A* 257 (1987) 279
- 1987SC08 D. Schmidt, D. Seeliger, G.N. Lovchikova and A.M. Trufanov, *Nucl. Sci. Eng.* 96 (1987) 159
- 1987SE1C Seth, Parker and Soundranayagam, in *Panic* (1987) 528
- 1987SU06 T. Suzuki, D.F. Measday and J.P. Roalsvig, *Phys. Rev. C* 35 (1987) 2212
- 1987SU1K D.P. Sural, *Indian J. Phys.* B61 (1987) 201
- 1987SV1A V.A. Sviciulis and R.K. Kalinauskas, *Sov. Phys.-Collect.* 27 (1987) 10
- 1987TA06 Y.C. Tang, *Nucl. Phys. A* 463 (1987) 377c
- 1987TA07 Y. Tagishi, Y. Aoki, M. Kurokawa, T. Murayama, T. Sakai, M. Takei, M. Tomizawa and K. Yagi, *Phys. Rev. C* 35 (1987) 1153
- 1987TA21 M. Tanaka, T. Yamagata, S. Nakayama, M. Inoue, Y. Sakuragi, M. Kamimura, K. Goto, K. Katori, M. Yanagi and H. Ogata, *Phys. Rev. C* 36 (1987) 2146

- 1987TAZU I. Tanihata, H. Hamagaki, O. Hashimoto, Y. Shida, O. Yamakawa, T. Kobayashi, K. Sugimoto and N. Takahashi, in *Panic* (1987) 474; LBL-22820 (1987) 82
- 1987TO06 M. Tosaki, M. Fujiwara, K. Hosono, T. Noro, H. Ito, T. Yamazaki and H. Ikegami, *Nucl. Phys. A*463 (1987) 429c
- 1987TR05 W. Trautmann, K.D. Hildenbrand, U. Lynen, W.F.J. Muller, H.J. Rabe, H. Sann, H. Stelzer, R. Trockel, R. Wada, N. Brummund et al., *Nucl. Phys. A*471 (1987) 191c
- 1987VA08 G. van der Steenhoven, A.M. van den Berg, H.P. Blok, S. Boffi, J.F.J. van den Brand, R. Ent, T. de Forest, Jr., C. Giusti, J.W.A. den Herder, E. Jans et al., *Phys. Rev. Lett.* 58 (1987) 1727
- 1987VA1N Van Der Steenhoven et al., in *Panic* (1987) 618
- 1987VA31 S.P. Van Verst, D.P. Sanderson, K.W. Kemper, D. Shapira, R.L. Varner and B. Shivakumar, *Phys. Rev. C*36 (1987) 1865
- 1987VAZY S.P. van Verst, D.P. Sanderson, K.W. Kemper, D.E. Trcka, G.A. Hall, V. Hnizdo, K.R. Chapman and B.G. Schmidt, *Bull. Amer. Phys. Soc.* 32 (1987) 1547, AE10
- 1987VD01 A.I. Vdovin and I.N. Loshchakov, *Yad. Fiz.* 45 (1987) 67; *Sov. J. Nucl. Phys.* 45 (1987) 42
- 1987VE1D Vetoshkin et al., in *Yurmala* (1987) 387
- 1987VU1A B. Vuaridel, W. Gruebler, V. König, P.A. Schmelzbach, K. Elsener, J. Ulbricht, D. Singy, Ch. Forstner, M. Bittcher, M. Bruno et al., *Helv. Phys. Acta.* 60 (1987) 326
- 1987WA09 R. Wada, K.D. Hildenbrand, U. Lynen, W.F.J. Muller, H.J. Rabe, H. Sann, H. Stelzer, W. Trautmann, R. Trockel, N. Brummund et al., *Phys. Rev. Lett.* 58 (1987) 1829
- 1987WA36 X.-C. Wang, H. Bando and H. Takaki, *Z. Phys. A* 327 (1987) 59
- 1987WE1A H.J. Weyer, *Helv. Phys. Acta* (Switzerland) 60 (1987) 667
- 1987WI09 J.S. Winfield, N. Anantaraman, S.M. Austin, Ziping Chen, A. Galonsky, J. van der Plicht, H.-L. Wu, C.C. Chang and G. Ciangaru, *Phys. Rev. C*35 (1987) 1734
- 1987WY1A D.R. Wyman, R.E. Stone and A.A. Harms, *Nucl. Sci and Eng.* 96 (1987) 46
- 1987YA16 Yu.P. Yakovlev, *Yad. Fiz.* 46 (1987) 459; *Sov. J. Nucl. Phys.* 46 (1987) 244
- 1987YA1M Y. Yamamoto, *Phys. Rev. C*36 (1987) 2166
- 1987YO01 H. Yokota, T. Mori, T. Katsumi, S. Igarashi, K. Hama, R. Chiba, K. Nakai, J. Chiba, H. Enyo, S. Sasaki et al., *Phys. Rev. Lett.* 58 (1987) 191
- 1987ZA07 M. Zadro, D. Miljanic, M. Lattuada, F. Riggi and C. Spitaleri, *Nucl. Phys. A*474 (1987) 373
- 1987ZH1D Zhusupov, Imambekov and Uzikov, in *Yurmala* (1987) 455
- 1987ZH1E Zhao et al., in *Panic* (1987) 710
- 1988AL1G Aleksandrov et al., in *Baku* (1988) 377

- 1988BA1F P.D. Barnes, Nucl. Phys. A478 (1988) 127c
- 1988BA1G P.D. Barnes, Nucl. Phys. A479 (1988) 89c
- 1988BA86 J.N. Bahcall and R.K. Ulrich, Rev. Mod. Phys. 60 (1988) 297
- 1988BE09 C.A. Bertulani and G. Baur, Nucl. Phys. A480 (1988) 615
- 1988BE1I Bekbaev et al., in Baku (1988) 442
- 1988BEYJ A.V. Belozerov, K. Borcha, I. Vintsour, Z. Dlougy, Nguen Khoai Tyau and Yu.Eh. Penionzhkevich, in Baku (1988) 380
- 1988BL09 C. Bloch, W. Benenson, A.I. Galonsky, E. Kashy, J. Heltsley, L. Heilbronn, M. Lowe, R.J. Radtke, B. Remington, J. Kassagi et al., Phys. Rev. C37 (1988) 2469
- 1988BO1J Bochkarev et al., in Baku (1988) 347
- 1988BR1E Brovkin et al., in Baku (1988) 430
- 1988BU1D Burkova et al., in Baku (1988) 315
- 1988BU1G Burkova et al., in Baku (1988) 426
- 1988BU1Q Buranov et al., in Baku (1988) 363
- 1988BUZH V.V. Buranov, N.I. Venikov, Yu.A. Glukhov, A.M. Dobyichin, A.A. Ogloblin, S.B. Sakuta and V.N. Unezhev, in Baku (1988) 362
- 1988CA06 G. Caskey, L. Heilbronn, B. Remington, A. Galonsky, F. Deak, A. Kiss and Z. Seres, Phys. Rev. C37 (1988) 696
- 1988CA11 P.J. Carlos, Ph. Bourgeois, J. Fagot, J.L. Fallou, P. Garganne, J.M. Laget, A. Lepretre, A. de Miniac, A. Veyssiere, J. Jury et al., Phys. Lett. B203 (1988) 33
- 1988CEZZ D.A. Cebra, W. Benenson, Y. Chen, E. Kashy, D.J. Morrissey, A. Pradhan, A. Vandermoden, G.D. Westfall, W.K. Wilson, R.S. Tickle et al., Bull. Amer. Phys. Soc. 33 (1988) 963, DI12
- 1988CH05 C.T. Christou, D.R. Lehman and W.C. Parke, Phys. Rev. C37 (1988) 445
- 1988CH06 C.T. Christou, D.R. Lehman and W.C. Parke, Phys. Rev. C37 (1988) 458
- 1988CH1D C.T. Christou, D.R. Lehman and W.C. Parke, Phys. Rev. C37 (1988) 477
- 1988CO1B Cook, Bull. Amer. Phys. Soc. 33 (1988) 1022
- 1988DA1D Danilin et al., in Baku (1988) 163
- 1988DA1E Danilin et al., in Baku (1988) 398
- 1988DA1F Danilin et al., in Baku (1988) 399
- 1988DAZW B.V. Danilin, M.V. Zhukov, A.A. Korshennikov, L.V. Chulkov and V.D. Efros, in Baku, (1988) 142
- 1988DE1F Demyanova et al., in Baku (1988) 332

- 1988DEZU A.S. Demyanova, A.A. Ogloblin, F.A. Gareev, S.N. Ershov and S.A. Goncharov, in Baku (1988) 330
- 1988DI02 S.S. Dietrich and B.L. Berman, *At. Data Nucl. Data Tables* 38 (1988) 199
- 1988EL01 K. Elsener, W. Gruebler, F. Sperisen, K. Ghazi-Wakili, V. Konig, P.A. Schmelzbach, B. Vuaridel, M. Bittcher, D. Singy and J. Ulbricht, *Nucl. Phys. A*481 (1988) 227
- 1988FO1A W.A. Fowler, *Interact. and Struct. in Nuclei*, Proc. Conf. to Honor D. Wilkinson FRS, 7-9 Sept. 1987, Brighton, UK (1988) 119
- 1988FR1B W.A. Friedman, *Phys. Rev. C*37 (1988) 976
- 1988FR1E L. Frankfurt and M. Strikman, *Phys. Rept.* 160 (1988) 235
- 1988FR1F W.A. Friedman, *Phys. Rev. Lett.* 60 (1988) 2125
- 1988GA1A A. Gal, *Nucl. Phys. A*479 (1988) 97c
- 1988GI1B B.F. Gibson, *Nucl. Phys. A*479 (1988) 115c
- 1988GIZT Yu.R. Gismatullin, A.A. Melentev, V.I. Ostroumov, A.M. Petukhov and M.A. Stalevich, in Baku (1988) 294
- 1988GIZU Yu.R. Gismatullin, A.A. Melentev, V.I. Ostroumov, A.M. Petukhov and M.A. Stalevich, in Baku (1988) 293
- 1988GO1H Goryonov et al., in Baku (1988) 367
- 1988GUZW I.R. Gulamov, A.M. Mukhamedzhanov and G.K. Ni, in Baku (1988) 300
- 1988HA12 S.S. Hanna, *J. Phys. (London)* G14 (1988) S283
- 1988HA1K O. Hausser, *AIP Conf. Proc.* 164 (1988) 604
- 1988HA44 R. Hausmann, *Nucl. Phys. A*479 (1988) 247c
- 1988HE08 R. Henneck, C. Gysin, P. Haffter, M. Hammans, W. Lorenzon, M.A. Pickar, I. Sick and S. Burzynski, *Phys. Rev. C*37 (1988) 2224
- 1988JA01 K.P. Jackson, A. Celler, W.P. Alford, K. Raywood, R. Abegg, R.E. Azuma, C.K. Campbell, S. El-Kateb, D. Frekers, P.W. Green et al., *Phys. Lett. B*201 (1988) 25
- 1988JI1A G.-Y. Jiang and X.-N. Jin, *Commun. Theor. Phys.* 9 (1988) 33
- 1988JO1C B. Jonson, S. Mattsson, G. Nyman, O. Tengblad, M.J.G. Borge, P.G. Hansen and K. Riisager, *AIP Conf. Proc.* 164 (1988) 223
- 1988KA09 K. Katori, T. Shimoda, T. Fukuda, S. Shimoura, A. Sakaguchi, M. Tanaka, T. Yamagata, N. Takahashi, H. Ogata, M. Kamimura et al., *Nucl. Phys. A*480 (1988) 323
- 1988KA1J Kaganov et al., in Baku (1988) 161
- 1988KI05 J.M. Kidd, P.J. Lindstrom, H.J. Crawford and G. Woods, *Phys. Rev. C*37 (1988) 2613
- 1988KO1C Kozchy, Mashkarov and Rudchik, in Baku (1988) 350
- 1988KU1C Kukulin et al., in Baku (1988) 160

- 1988LA1C A. Lamberty and P. de Bievre, *Int. J. Mass Spectrom. Ion Proc.* 83 (1988) 135
- 1988LE06 M. LeMere and Y.C. Tang, *Phys. Rev. C37* (1988) 1369
- 1988LI1A Liu et al., *Bull. Amer. Phys. Soc.* 33 (1988) 903
- 1988MCZY M. McMaster, A. Nadasen, M. Fingal, F.D. Becchetti, J. Janecke, J. Winfield, R.M. Ronningen, P. Schwandt and R.E. Warner, *Bull. Amer. Phys. Soc.* 33 (1988) 1102, KJ14
- 1988MIZX J. Mildenberger, O. Hausser, R. Abegg, W.P. Alford, A. Celler, D. Frekers, R. Helmer, R. Henderson, K. Hicks, K.P. Jackson, R. Jeppesen et al., *Bull. Amer. Phys. Soc.* 33 (1988) 1180, AG5
- 1988NA02 A. Nadasen, M. McMaster, G. Gunderson, A. Judd, S. Villanueva, P. Schwandt, J.S. Winfield, J. van der Plicht, R.E. Warner, F.D. Becchetti et al., *Phys. Rev. C37* (1988) 132
- 1988NAZX A. Nadasen, A. McMaster, J. Tavormina, F.D. Becchetti, J.W. Janecke, P. Schwandt, J. Winfield and R.E. Warner, *Bull. Amer. Phys. Soc.* 33 (1988) 1101, KJ13
- 1988PO1H B. Povh, *Prog. Part. Nucl. Phys.* 20 (1988) 353
- 1988POZS N.A.F.M. Poppelier, J.H. de Vries, A.A. Wolters and P.W.M. Glaudemans, *AIP Conf. Proc.* 164 (1988) 334
- 1988PUZZ V. Punjabi, C.F. Perdrisat, C. Lyndon, P. Ulmer, J. Yonnet, R. Beurtey, M. Boivin, A. Boudard, F. Plouin, J.P. Didelez et al., *Bull. Amer. Phys. Soc.* 33 (1988) 962, DI7
- 1988RE1B R. Rebolo, P. Molaro, C. Abia and J.E. Beckman, *Astron. Astrophys.* 193 (1988) 193
- 1988ROZZ D. Rothenberger, B.G. Ritchie, J.R. Comfort, R.A. Giannelli, J. Tinsley, N.S. Chant, D. Mack, P.G. Roos, J.D. Silk, G.S. Kyle et al., *Bull. Amer. Phys. Soc.* 33 (1988) 903, AI12
- 1988RU01 V.A. Rubchenya and S.G. Yavshits, *Z. Phys.* A329 (1988) 217
- 1988RYZW I.Yu. Rybkin, V.S. Vasilevsky and O. Velaskes, in *Baku* (1988) 428
- 1988SA15 Y. Sakuragi, M. Kamimura and K. Katori, *Phys. Lett.* B205 (1988) 204
- 1988SA19 H. Sato, *Phys. Rev. C37* (1988) 2902
- 1988SA2J Samsonenko, Adamu and Samgin, in *Baku* (1988) 263
- 1988SEZJ K.K. Seth, *AIP Conf. Proc.* 164 (1988) 324
- 1988SH1E Shvedov, Nemets and Rudchik, in *Baku* (1988) 351
- 1988ST06 J. Stevenson, B.A. Brown, Y. Chen, J. Clayton, E. Kashy, D. Mikolas, J. Nolen, M. Samuel, B. Sherrill, J.S. Winfield et al., *Phys. Rev. C37* (1988) 2220
- 1988TA1A I. Tanihata, *Nucl. Phys.* A478 (1988) 795c
- 1988TA29 H. Tamura, W. Bruckner, H. Dobbeling, R.S. Hayano, T. Ishikawa, M. Iwasaki, T. Motoki, H. Outa, S. Paul, B. Povh et al., *Nucl. Phys.* A479 (1988) 161c

- 1988TRZY D.E. Trcka, S.P. Van Verst, A.D. Frawley, K.W. Kemper, J.D. Fox, V. Hnizdo and E.G. Myers, Bull. Amer. Phys. Soc. 33 (1988) 1101, KJ12
- 1988TS03 M.B. Tsang, W.G. Lynch, R.M. Ronningen, Z. Chen, C.K. Gelbke, T. Nayak, J. Pochodzalla, F. Zhu, M. Tohyama, W. Trautmann et al., Phys. Rev. Lett. 60 (1988) 1479
- 1988US1A Usmanov, Zhusupov and Ivkina, in Baku (1988) 168
- 1988VA03 A.G.M. van Hees, A.A. Wolters and P.W.M. Glaudemans, Nucl. Phys. A476 (1988) 61
- 1988VA18 K. Varga and R.G. Lovas, Phys. Rev. C37 (1988) 2906
- 1988VA1E Vagner et al., in Baku (1988) 383
- 1988VAZY S.P. Van Verst, K.W. Kemper, D.E. Trcka, G.A. Hall, V. Hnizdo, K.R. Chapman and B.G. Schmidt, Bull. Amer. Phys. Soc. 33 (1988) 1101, KJ11
- 1988VD1A Vdovin, Golikov, Zhukov and Lozchakov, in Baku (1988) 274
- 1988WA18 A.H. Wapstra, G. Audi and R. Hoekstra, At. Data Nucl. Data Tables 39 (1988) 281
- 1988WO04 A.A. Wolters, A.G.M. van Hees and P.W.M. Glaudemans, Europhys. Lett. 5 (1988) 7
- 1988WO10 C.L. Woods, F.C. Barker, W.N. Catford, L.K. Fifield and N.A. Orr, Aust. J. Phys. 41 (1988) 525
- 1990AJ01 F. Ajzenberg-Selove, Nucl. Phys. A506 (1990) 1

