

Energy Levels of Light Nuclei $A = 9$

F. Ajzenberg-Selove

University of Pennsylvania, Philadelphia, Pennsylvania 19104-6396

Abstract: An evaluation of $A = 5-10$ was published in *Nuclear Physics A490* (1988), p. 1. This version of $A = 9$ differs from the published version in that we have corrected some errors discovered after the article went to press. The introduction and introductory tables have been omitted from this manuscript. [Reference](#) key numbers have been changed to the NNDC/TUNL format.

(References closed June 1, 1988)

The original work of Fay Ajzenberg-Selove was supported by the US Department of Energy [DE-FG02-86ER40279]. Later modification by the TUNL Data Evaluation group was supported by the US Department of Energy, Office of High Energy and Nuclear Physics, under: Contract No. DEFG05-88-ER40441 (North Carolina State University); Contract No. DEFG05-91-ER40619 (Duke University).

Table of Contents for $A = 9$

Below is a list of links for items found within the PDF document. The introductory [Table 2](#) is available on this website via the link.

A. Nuclides: [\${}^9\text{n}\$](#) , [\${}^9\text{He}\$](#) , [\${}^9\text{Li}\$](#) , [\${}^9\text{Be}\$](#) , [\${}^9\text{B}\$](#) , [\${}^9\text{C}\$](#) , [\${}^9\text{N}\$](#)

B. Tables of Recommended Level Energies:

[Table 9.1](#): Energy levels of ${}^9\text{Li}$

[Table 9.2](#): Energy levels of ${}^9\text{Be}$

[Table 9.9](#): Energy levels of ${}^9\text{B}$

[Table 9.11](#): Energy levels of ${}^9\text{C}$

C. [References](#)

D. Figures: [\${}^9\text{Li}\$](#) , [\${}^9\text{Be}\$](#) , [\${}^9\text{B}\$](#) , [Isobar diagram](#)

E. Erratum to the Publication: [PS](#) or [PDF](#)

⁹n
(Not illustrated)

Not observed: see (1979AJ01) and (1983BE55; theor.).

⁹He
(Fig. 4)

⁹He has been observed in the ⁹Be(¹⁴C, ¹⁴O) reaction at $E(^{14}\text{C}) = 158$ MeV (1987BEYI) and in the ⁹Be(π^- , π^+) reaction at $E_{\pi^-} = 180$ and 194 MeV (1987SE05): the atomic mass excesses are 41.5 ± 1.0 MeV and 40.80 ± 0.10 MeV, respectively. We adopt the latter value. ⁹He is then unstable with respect to decay into ⁸He + n by 1.13 MeV. (1987SE05) also report the population of excited states of ⁹He at 1.2, 3.8 and 7.0 MeV, while (1987BEYI) suggest an excited state at ≈ 1.8 MeV with $\Gamma \approx 3$ MeV. Excited states are calculated at 1.64, 3.86 and 6.53 MeV, with $J^\pi = \frac{1}{2}^+$, $\frac{5}{2}^+$ and $\frac{3}{2}^-$ [(0+1) $\hbar\omega$ model space]. In the (0+2) $\hbar\omega$ model space the normal-parity excited states are at 6.44, 29.09 and 29.42 MeV with $J^\pi = \frac{3}{2}^-$, $\frac{7}{2}^-$, $\frac{3}{2}^-$. In both cases the ground state is $J^\pi = \frac{1}{2}^-$, as would be expected (1985PO10). See also (1984BE1C, 1988BEYJ), (1985AL1G, 1985SE1B, 1986FL1A, 1986FL1B, 1987HA1R, 1987PE1C, 1988SEZJ) and (1983ANZQ, 1984VA06, 1986AN07, 1987GI1C, 1987IK1B; theor.).

⁹Li
(Figs. 1 and 4)

GENERAL: See also (1984AJ01).

Model calculations: (1983KU17, 1984CH24, 1984VA06).

Special states: (1983KU17, 1984VA06).

Electromagnetic interactions: (1983KU17).

Astrophysical questions: (1987MA2C).

Complex reactions involving ⁹Li: (1983OL1A, 1983WI1A, 1984GR08, 1985JA18, 1985MA02, 1985MO17, 1986CS1A, 1986HA1B, 1986SA30, 1986WE1C, 1987BA38, 1987CH26, 1987JA06, 1987KO1Z, 1987SH1K, 1987TAZU, 1987WA09, 1987YA16, 1988CA06, 1988RU01, 1988ST06, 1988TA1A).

Reactions involving pions and other mesons (See also reactions 3 and 4.): (1985PN01).

Hypernuclei: (1982KA1D, 1983FE07, 1984AS1D, 1985PN01, 1986DA1B, 1986KO1A, 1986ME1F, 1987MI38, 1987PO1H, 1987WA36, 1988TA29).

Other topics: (1985AN28, 1985PO10, 1986AN07, 1987BA1I).

Ground-state properties of ${}^9\text{Li}$: (1983ANZQ, 1984CH24, 1985AN28, 1985SA32, 1987HA30, 1988JO1C, 1988POZS, 1988VA03)

$$\mu = 3.4391 \pm 0.0006 \text{ nm (1983CO11)}. \text{ See also (1987AR22).}$$

$$Q = (0.88 \pm 0.18) Q \text{ of } {}^7\text{Li (1983CO11)}.$$

[A preliminary report by (1988ARZU) gives $Q = (0.69 \pm 0.03) \times Q({}^7\text{Li})$.]

The interaction nuclear radius of ${}^9\text{Li}$ is $2.41 \pm 0.02 \text{ fm (1985TA18)}$. [See also for derived nuclear matter, charge and neutron matter r.m.s. radii.]

$$1. {}^9\text{Li}(\beta^-){}^9\text{Be} \quad Q_m = 13.606$$

The half-life of ${}^9\text{Li}$ is $178.3 \pm 0.4 \text{ msec}$: see (1979AJ01). See also (1986CU01, 1988SA04). ${}^9\text{Li}$ decays to a number of states in ${}^9\text{Be}$: see reaction 12 in ${}^9\text{Be}$ and Table 9.7. The nature of the decay to ${}^9\text{Be}^*(0, 2.43)$ with $J^\pi = \frac{3}{2}^-, \frac{5}{2}^-$ is evidence for $J^\pi = \frac{3}{2}^-$ for ${}^9\text{Li}_{\text{g.s.}}$. The probability for delayed neutron decay, P_n , is $(49.5 \pm 5)\%$: see (1984AJ01). See also (1986RO27), (1985HA1K) and (1983KU17; theor.).

$$2. {}^7\text{Li}(t, p){}^9\text{Li} \quad Q_m = -2.386$$

Protons are observed to excited states at $E_x = 2.691 \pm 0.005, 4.31 \pm 0.02, 5.38 \pm 0.06$ and $6.430 \pm 0.015 \text{ MeV}$. The widths of the three highest states, which are unbound, are $100 \pm 30, 600 \pm 100$ and $40 \pm 20 \text{ keV}$, respectively. Angular distributions have been studied at $E_t = 11.3, 15$ and 23 MeV . At the highest energy they are consistent with $J^\pi = \frac{3}{2}^-, (\frac{1}{2}^-)$ and $\geq \frac{9}{2}$ for ${}^9\text{Li}^*(0, 2.69, 6.43)$: see (1979AJ01). See also (1984AJ01) and ${}^{10}\text{Be}$.

Fig. 1: Energy levels of ${}^9\text{Li}$. In these diagrams, energy values are plotted vertically in MeV, based on the ground state as zero. Uncertain levels or transitions are indicated by dashed lines; levels which are known to be particularly broad are cross-hatched. Values of total angular momentum J , parity, and isobaric spin T which appear to be reasonably well established are indicated on the levels; less certain assignments are enclosed in parentheses. For reactions in which ${}^9\text{Li}$ is the compound nucleus, some typical thin-target excitation functions are shown schematically, with the yield plotted horizontally and the bombarding energy vertically. Bombarding energies are indicated in laboratory coordinates and plotted to scale in cm coordinates. Excited states of the residual nuclei involved in these reactions have generally not been shown; where transitions to such excited states are known to occur, a brace is sometimes used to suggest reference to another diagram. For reactions in which the present nucleus occurs as a residual product, excitation functions have not been shown; a vertical arrow with a number indicating some bombarding energy, usually the highest, at which the reaction has been studied, is used instead. Further information on the levels illustrated, including a listing of the reactions in which each has been observed, is contained in the master table, entitled “Energy levels of ${}^9\text{Li}$ ”.

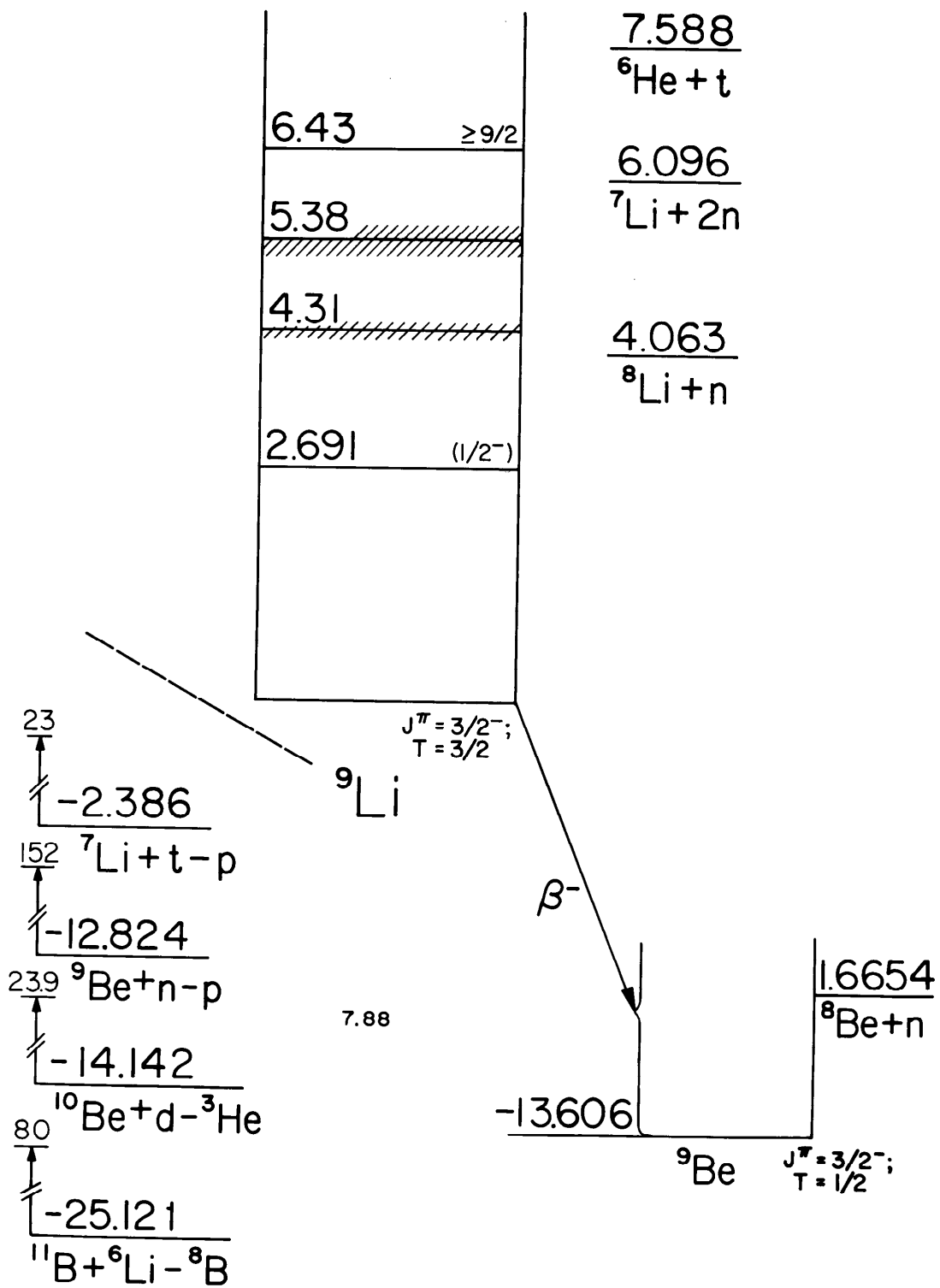

Table 9.1: Energy Levels of ${}^9\text{Li}$

| E_x (MeV \pm keV) | $J^\pi; T$ | $\tau_{1/2}$ or $\Gamma_{\text{c.m.}}$ (keV) | Decay | Reactions |
|-----------------------|------------------------------|--|------------|------------------|
| g.s. | $\frac{3^-}{2}; \frac{3}{2}$ | $\tau_{1/2} = 178.3 \pm 0.4$ msec | β^- | 1, 2, 3, 4, 5, 6 |
| 2.691 ± 5 | $(\frac{1^-}{2})$ | | (γ) | 2, 4, 6 |
| 4.31 ± 20 | | $\Gamma = 100 \pm 30$ | | 2, 6 |
| 5.38 ± 60 | | 600 ± 100 | | 2 |
| 6.43 ± 15 | $\geq \frac{9}{2}$ | 40 ± 20 | | 2, 6 |

3. ${}^9\text{Be}(\gamma, \pi^+){}^9\text{Li}$ $Q_m = -153.175$

The angular distribution of the π^+ to ${}^9\text{Li}_{\text{g.s.}}$ has been measured at $E_e = 200$ MeV (1983SH19). For the earlier work see (1984AJ01).

4. ${}^9\text{Be}(\pi^-, \gamma){}^9\text{Li}$ $Q_m = 125.962$

Capture branching ratios to ${}^9\text{Li}^*(0, 2.69)$ are reported by (1986PE05).

5. ${}^9\text{Be}({}^7\text{Li}, {}^7\text{Be}){}^9\text{Li}$ $Q_m = -14.468$

See (1984GL06: $E({}^7\text{Li}) = 78$ MeV).

6. ${}^{11}\text{B}({}^6\text{Li}, {}^8\text{B}){}^9\text{Li}$ $Q_m = -25.121$

At $E({}^6\text{Li}) = 80$ MeV the angular distribution to ${}^9\text{Li}_{\text{g.s.}}$ has been measured. States at $E_x = 2.59 \pm 0.10, 4.36 \pm 0.10$ and 6.38 ± 0.12 MeV are also populated: see (1979AJ01).

⁹Be
(Figs. 2 and 4)

GENERAL: See also (1984AJ01).

Shell model: 1983VA31, 1984VA06, 1984ZW1A, 1985AN16, 1987KI1C, 1988OR1C, 1988WO04).

Cluster and α -particle models: (1981PL1A, 1982DZ1A, 1983JA09, 1983MI1E, 1983SH38, 1985HA1P, 1985KW02, 1986CR1B, 1987VOZU).

Special states: (1981PL1A, 1983AU1B, 1983GO28, 1983MI08, 1983VA31, 1984BA49, 1984KO40, 1984VA06, 1984WO09, 1984ZW1A, 1985GO1A, 1985HA1J, 1985PO19, 1985SH24, 1986AN07, 1986WI04, 1987KI1C, 1987VOZU, 1988KW02).

Electromagnetic transitions and giant resonances: (1983GM1A, 1983MI08, 1984BA49, 1984MO1D, 1984VA06, 1985GO1A, 1986ER1A, 1986SC1F, 1987HO1L, 1987KI1C).

Astrophysical questions: (1982AU1A, 1982CA1A, 1983SI1B, 1984TR1C, 1985MI1E, 1985WA1K, 1985WE1A, 1986BO1H, 1987AR1C, 1987AU1A, 1987DW1A, 1987MA2C, 1987RO25, 1988RE1B, 1988SA2H).

Complex reactions involving ⁹Be: (1983CH23, 1983EF1A, 1983EN04, 1983GU1A, 1983HA1C, 1983MA53, 1983NA08, 1983OL1A, 1983SO08, 1983ST1A, 1983VA23, 1983WA1F, 1983WI1A, 1984AI1A, 1984GR08, 1984HI1A, 1984IS02, 1984RE14, 1984SI15, 1984XI1B, 1985AG1A, 1985BA1V, 1985BH02, 1985FA02, 1985MA13, 1985MC03, 1985MO08, 1985MO17, 1985MO24, 1985PO11, 1985PO19, 1985RO10, 1985SH1G, 1985TR1B, 1985WA1F, 1985WA22, 1986AV1B, 1986BA2D, 1986BA2H, 1986BA1Q, 1986HA1B, 1986MA19, 1986MA1O, 1986ME06, 1986PO06, 1986RE13, 1986SA30, 1986SH1F, 1986SIZS, 1986SO10, 1986WA1H, 1986WE1C, 1987AK1A, 1987AR19, 1987AU1C, 1987BA38, 1987BO23, 1987DE37, 1987FA09, 1987FE1A, 1987GO17, 1987GR11, 1987HE1H, 1987JA06, 1987KIZY, 1987KO15, 1987KW02, 1987LY04, 1987MU03, 1987MU1D, 1987NA01, 1987PO03, 1987SH23, 1987SI1C, 1987SO13, 1987SO15, 1987ST01, 1987TAZU, 1987TR05, 1987VI14, 1987WA09, 1987YA16, 1987YI1A, 1988BL09, 1988CA06, 1988CH04, 1988GO1F, 1988KA1L, 1988KI05, 1988KR11, 1988POZZ, 1988PO1F, 1988RU01, 1988SA2H, 1988SA19, 1988SH1E, 1988TS03).

Applications: (1983KU1C, 1984CA1D, 1984IM1A, 1987IN1A, 1987KU1L).

Muon and neutrino capture and reactions: (1983GM1A, 1983GU10, 1984RO1B, 1987KU23, 1987SU06).

Reactions involving pions (See also reactions 2 and 17.): (1983BU1D, 1983GE12, 1983GM1A, 1983HA45, 1983SH19, 1983SU08, 1983ZA1B, 1984BO1H, 1984HA1K, 1984LE11, 1985AR15, 1985BA1V, 1985LA20, 1985IM1A, 1985MA1G, 1985MO1F, 1985PN01, 1986CE04, 1986PE05, 1986RO03, 1986YA1D, 1986ZO1A, 1987AN14, 1987GOZN, 1987GO25, 1987GR1G, 1987MA1I, 1987PI1B, 1988BA82, 1988GIZU, 1988KA1N).

Reactions involving kaons and other mesons: (1983BA71, 1983BR1E, 1983FE07, 1983GE13, 1983GE1C, 1983PO1D, 1983ZA1B, 1984BO1H, 1984MO09, 1985MO1F, 1985YA05, 1986AB07, 1986BA1W, 1986CH1P, 1986DO1B, 1986FI1A, 1986GA1H, 1986YA1D, 1986YA02, 1986ZO1A, 1987PI1B, 1987PO1H, 1987YA1I, 1988BA82, 1988MO1B, 1988KH03, 1988WA1B).

Antinucleon reactions: (1987LE32, 1988KA1N).

Hypernuclei: (1982DZ1A, 1982MO1B, 1983AU1A, 1983BA1M, 1983BA1D, 1983BR1E, 1983FE07, 1983KO1C, 1983MA64, 1983MI1E, 1983MO1C, 1983OR1A, 1983PO1D, 1983SH1E, 1983ZH1B, 1984BA1N, 1984BO1A, 1984BO1H, 1984CH1G, 1984CH1H, 1984DA1D, 1984JI05, 1984KO1B, 1984MI1C, 1984MI1E, 1984MO09, 1984MO1H, 1984SC1A, 1984ZH1B, 1985HA1P, 1985IK1A, 1985MO1F, 1985YA05, 1985YU1A, 1986BA1W, 1986BO1E, 1986CH1P, 1986DO1B, 1986ER1A, 1986GA1H, 1986MA1C, 1986MA1W, 1986ME1F, 1986PO1G, 1986SH1V, 1986WA1J, 1986YA1D, 1986YA1F, 1986YA02, 1986YU1A, 1987BA2K, 1987BO1L, 1987BO1O, 1987IK1B, 1987JI1A, 1987PI1C, 1987PO1H, 1987WA36, 1987YA1I, 1987YA1C, 1987YA1M, 1988BA82, 1988CH48, 1988HA44, 1988JI1A, 1988MA1G, 1988MO1B, 1988KH03, 1988TA29, 1988WA1B).

Other topics: (1984CL11, 1984DA11, 1984PO11, 1985AN28, 1985AR1B, 1985EL1A, 1985KA01, 1985SH24, 1986BI01, 1986KU11, 1986IS04, 1986SA02, 1986SC1F, 1987KU1I, 1988KW02, 1988OR1C).

Ground-state properties of ${}^9\text{Be}$: (1983ANZQ, 1983AU1B, 1983KU06, 1983VA31, 1984AN1B, 1984BR25, 1984FR13, 1984MIZM, 1985AN16, 1985AN28, 1985BE59, 1985CL1A, 1985GO1A, 1985HA1P, 1985SA32, 1986CR1B, 1986JI01, 1986GL1A, 1986RO03, 1986SY1A, 1986WI04, 1987HA30, 1987KI1C, 1987LE33, 1987SA15, 1988JO1C, 1988VA03, 1988WO04).

$$\mu = -1.1778 \pm 0.0009: \text{ see (1978LEZA).}$$

$$Q = +(53 \pm 3) \text{ mb: see (1978LEZA).}$$

The interaction nuclear radius of ${}^9\text{Be}$ is 2.45 ± 0.01 fm [(1985TA18); $E = 790$ MeV/ A : see also for derived nuclear matter, charge and neutron matter r.m.s. radii].

The decay ${}^9\text{Li}_\Lambda \rightarrow \pi^- + {}^9\text{Be}^* \rightarrow \pi^- + p + {}^8\text{Li}$ appears to take place via a $T = \frac{3}{2}$ state of ${}^9\text{Be}$ at $E_x = 18.6 \pm 0.1$ MeV ($\Gamma \leq 300$ keV) (1985PN01).

| | | |
|---|-----------------|-----------------|
| 1. (a) ${}^6\text{Li}(t, n){}^8\text{Be}$ | $Q_m = 16.0225$ | $E_b = 17.6879$ |
| (b) ${}^6\text{Li}(t, p){}^8\text{Li}$ | $Q_m = 0.801$ | |
| (c) ${}^6\text{Li}(t, n)2 {}^4\text{He}$ | $Q_m = 16.1144$ | |

The 0° differential cross section for reaction (a) increases monotonically between $E_t = 0.10$ and 2.4 MeV. A resonance has been reported at $E_t = 1.875$ MeV (${}^9\text{Be}^*(18.94)$). The excitation function for ${}^8\text{Li}$ (reaction (b)) increases monotonically for $E_t = 0.275$ to 1.000 MeV. See (1974AJ01) for references. In the range $E_t = 2$ to 10 MeV the total cross section for reaction (b)

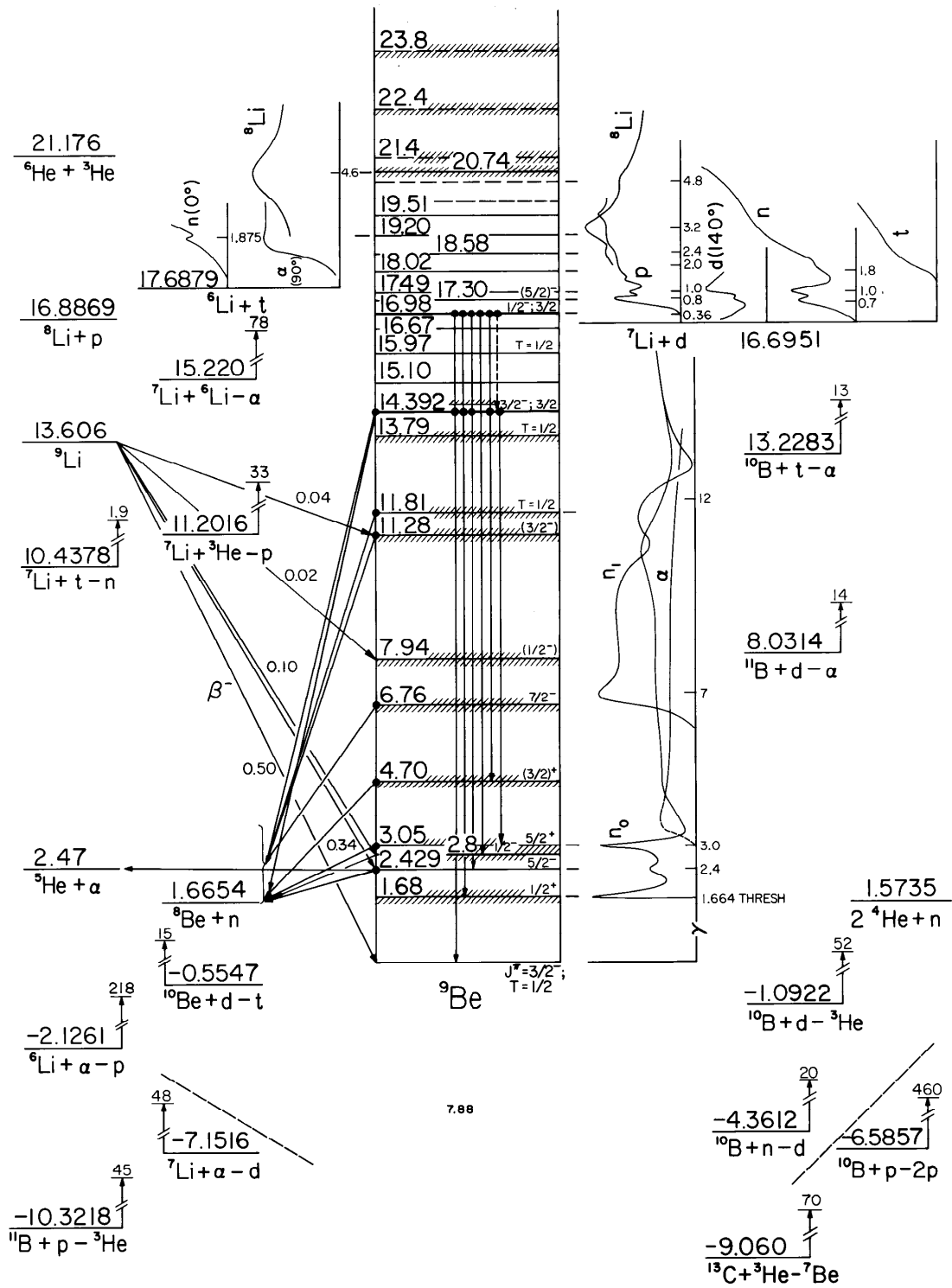

Fig. 2: Energy levels of ${}^9\text{Be}$. For notation see Fig. 1.

shows a broad structure [$\Gamma_{\text{c.m.}} = 1.5 \text{ MeV}$] at $E_t = 4.2 \text{ MeV}$ (${}^9\text{Be}^* = 20.5 \text{ MeV}$) (1986AB04; prelim.). Yields and angular distributions for reaction (c) have been measured at $E_t = 2$ to 4.5 MeV (1984LIZY; prelim.). See also (1984AJ01) for other channels and (1984KR1B; theor.).

2. ${}^6\text{Li}({}^3\text{He}, \pi^+){}^9\text{Be}$

$$Q_m = -121.899$$

The energy dependence of the π^+ to ${}^9\text{Be}_{\text{g.s.}}$ has been measured at $E({}^3\text{He}) = 235$ to 283 MeV (1984WI06).

Table 9.2: Energy Levels of ${}^9\text{Be}$

| E_x^a (MeV \pm keV) | $J^\pi; T$ | $\Gamma_{\text{c.m.}}$ (keV) | Decay | Reactions |
|----------------------------|------------------------------|------------------------------|---------------------|--|
| g.s. | $\frac{3}{2}^-; \frac{1}{2}$ | | stable | 2, 3, 4, 9, 10, 11, 12, 13, 14, 15, 16, 17, 18, 19, 20, 21, 22, 23, 24, 25, 26, 27, 28, 29, 30, 31, 32, 33, 34, 35, 36, 37, 38, 40, 41, 42, 43, 44, 45, 46, 48 |
| 1.684 ± 7 | $\frac{1}{2}^+$ | 217 ± 10 | γ, n | 4, 9, 10, 13, 16, 18, 19, 21, 23, 24, 32, 36, 38, 40 |
| 2.4294 ± 1.3 | $\frac{5}{2}^-$ | 0.77 ± 0.15 | γ, n, α | 4, 9, 10, 11, 12, 16, 17, 18, 19, 21, 22, 23, 24, 25, 26, 32, 33, 35, 36, 37, 38, 40, 44 |
| 2.78 ± 120 | $\frac{1}{2}^-$ | 1080 ± 110 | n | 4, 9, 12, 38, 44 |
| 3.049 ± 9 | $\frac{5}{2}^+$ | 282 ± 11 | γ, n | 4, 9, 16, 18, 19, 21, 23, 24, 32, 36, 38, 40 |
| 4.704 ± 25 | $(\frac{3}{2})^+$ | 743 ± 55 | γ, n | 4, 9, 16, 21, 23, 24, 38, 44 |
| 6.76 ± 60 | $\frac{7}{2}^-$ | 1540 ± 200 | γ, n | 9, 11, 16, 17, 18, 19, 21, 23, 24, 25, 35, 40 |
| 7.94 ± 80 | $(\frac{1}{2}^-)$ | ≈ 1000 | | 12, 19 |
| 11.283 ± 24 | | 575 ± 50 | n | 9, 12, 19, 24, 35, 36 |
| 11.81 ± 20 | $T = \frac{1}{2}$ | 400 ± 30 | γ, n | 9, 12, 13, 37, 44 |
| 13.79 ± 30 | $T = \frac{1}{2}$ | 590 ± 60 | γ, n | 9, 16, 37 |

Table 9.2: Energy Levels of ${}^9\text{Be}$ (continued)

| E_x^a (MeV \pm keV) | $J^\pi; T$ | $\Gamma_{\text{c.m.}}$ (keV) | Decay | Reactions |
|--------------------------------|------------------------------|------------------------------|---------------------------|-----------------------|
| 14.3922 \pm 1.8 ^c | $\frac{3}{2}^-; \frac{3}{2}$ | 0.381 \pm 0.033 | γ, n, α | 9, 16, 19, 23, 36, 37 |
| 14.4 \pm 300 | | \approx 800 | | 36 |
| 15.10 \pm 50 | | | γ | 16, 37 |
| 15.97 \pm 30 | $T = \frac{1}{2}$ | \approx 300 | γ | 16, 37 |
| 16.671 \pm 8 | $(\frac{5}{2}^+)$ | 41 \pm 4 | γ | 9, 16, 19, 36 |
| 16.9752 \pm 0.8 ^d | $\frac{1}{2}^-; \frac{3}{2}$ | 0.49 \pm 0.05 | γ, n, p, d | 4, 5, 6, 15, 16 |
| 17.298 \pm 7 | $(\frac{5}{2})^-$ | 200 | γ, n, p, d, α | 5, 6, 7, 13, 16, 19 |
| 17.493 \pm 7 | $(\frac{7}{2})^+$ | 47 | γ, n, p, d, α | 5, 6, 7, 16, 19 |
| 18.02 \pm 50 | | | γ | 16 |
| 18.58 \pm 40 | | | γ, n, p, d, α | 6, 16 |
| (18.6 \pm 100) ^e | $(T = \frac{3}{2})$ | \leq 300 | p | |
| 19.20 \pm 50 | | 310 \pm 80 | n, p, d, t | 6 |
| 19.51 \pm 50 | | | γ | 13, 16 |
| (19.9 \pm 200) | | | γ, n | 13 |
| (20.47 \pm 40) | | | γ, p, d | 13 |
| 20.74 \pm 30 | | \approx 1000 | γ, n, p, t | 13, 16 |
| (21.4 \pm 200) | | | γ, n | 13 |
| (22.4 \pm 200) | | broad | γ, n | 13, 19 |
| (23.8 \pm 200) | | | γ, n | 13 |
| (27.0 \pm 500) | | broad | γ, n | 13 |
| b | | | | |

^a See also reactions 14 and 16.

^b See footnote ^j in Table 9.8 of (1984AJ01).

^c See Table 9.3.

^d See Table 9.4.

^e See the “General” section here.

3. ${}^6\text{Li}(\alpha, p){}^9\text{Be}$

$$Q_m = -2.1261$$

Table 9.3: Parameters of the first $T = \frac{3}{2}$ states in ${}^9\text{Be}$ and ${}^9\text{B}$, $J^\pi = \frac{3}{2}^-$ ^a

| | ${}^9\text{Be}$ | | ${}^9\text{B}$ |
|---|-------------------|---------------------------------|-------------------|
| E_x (keV) | 14392.2 ± 1.8 | | 14655.0 ± 2.5 |
| Γ_{γ_0} (eV) | 6.9 ± 0.5 | | $(6.9 \pm 0.5)^b$ |
| Γ (eV) | 381 ± 33 | | 395 ± 42 |
| Γ_{γ_0} (to $\frac{3}{2}^-$)/ Γ (%) | 1.81 ± 0.09 | | 1.85 ± 0.15 |
| Γ_{γ_1} (to $\frac{1}{2}^+$)/ Γ (%) | 0.03 ± 0.04 | | 0.00 ± 0.08 |
| Γ_{γ_2} (to $\frac{5}{2}^-$)/ Γ (%) | 2.05 ± 0.11 | | 1.93 ± 0.22 |
| Γ_{γ_3} (to $\frac{1}{2}^-$)/ Γ (%) | < 0.2 | | } 0.31 ± 0.18 |
| Γ_{γ_4} (to $\frac{5}{2}^+$)/ Γ (%) | 0.33 ± 0.07 | | |
| Γ_{γ_5} (to $\frac{3}{2}^+$)/ Γ (%) | 0.23 ± 0.05 | | |
| $\Gamma_{\gamma_2}/\Gamma_{\gamma_0}$ | 1.13 ± 0.05 | | 1.03 ± 0.11 |
| Γ_{n_0}/Γ | 0.028 ± 0.021 | Γ_{p_0}/Γ | 0.11 ± 0.04 |
| Γ_{n_1}/Γ | 0.50 ± 0.11 | Γ_{p_1}/Γ | 0.33 ± 0.09 |
| Γ_{n_0} (eV) | 9 ± 8 | Γ_{p_0} (eV) | 30 ± 17 |
| Γ_{n_1} (eV) | 147 ± 28 | Γ_{p_1} (eV) | 95 ± 15 |
| $\Gamma_{n_1}/\Gamma_{n_0}$ | 18 ± 14 | $\Gamma_{p_1}/\Gamma_{p_0}$ | 3.2 ± 1.9 |
| $\gamma_{n_1}^2/\gamma_{n_0}^2$ | 22 ± 17 | $\gamma_{p_1}^2/\gamma_{p_0}^2$ | 3.7 ± 2.2 |
| $\Gamma_{\alpha_0}/\Gamma_{\gamma_0}$ | 31.2 ± 9.8 | | |

^a See Tables 9.6 in (1979AJ01, 1984AJ01) for references.

^b Assumed identical to ${}^9\text{Be}$.

Angular distributions of p_0 have been measured at $E_\alpha = 10.2$ to 14.7 MeV and at 30 MeV: see (1974AJ01). See also (1987BI1C) and (1983BE51; theor.).

4. ${}^7\text{Li}(d, \gamma){}^9\text{Be}$

$$Q_m = 16.6951$$

For $E_d = 0.1$ to 1.1 MeV, a resonance in the yield of capture γ -rays is observed at $E_d = 360.8 \pm 0.3$ keV (1987ZI01), 360.7 ± 1.8 keV (1986BE33), corresponding to the excitation of ${}^9\text{Be}^*(16.97)$, the second $T = \frac{3}{2}$ state [$J^\pi = \frac{1}{2}^-$]: see Table 9.4 (1987ZI01). The reduced width for the isospin “forbidden” deuteron breakup is 5.4×10^{-4} relative to the Wigner limit (1987ZI01). See also (1984AJ01).

5. (a) ${}^7\text{Li}(d, n){}^8\text{Be}$ $Q_m = 15.0297$ $E_b = 16.6951$
 (b) ${}^7\text{Li}(d, \alpha){}^5\text{He}$ $Q_m = 14.23$
 (c) ${}^7\text{Li}(d, n)2\text{ }{}^4\text{He}$ $Q_m = 15.1216$

The yield of neutrons has been measured for $E_d = 0.2$ to 23 MeV [see (1979AJ01)] and at $E_d = 0.19$ to 0.55 MeV (1987DA25). See also (1983SZZY). Polarization measurements have been carried out at $E_d = 0.64$ MeV and 2.5 to 3.7 MeV [see (1974AJ01)] and at 0.40 and 0.46 MeV (1984GA07; n_0). Resonances are reported at 0.36 , 0.68 and 0.98 MeV: see Table 9.3 in (1974AJ01). See also (1985CA41; astrophys.).

The yields of α -particles have been measured for $E_d = 0.25$ to 3.0 MeV: see (1974AJ01, 1979AJ01). Resonances are reported at $E_d = 0.75$, 1.00 and 2.5 MeV; the latter is broad: see Table 9.3 in (1979AJ01). See also (1983SZZY), (1986DIZT, 1987LE1F; applied) and (1984KR1B; theor.).

6. ${}^7\text{Li}(d, p){}^8\text{Li}$ $Q_m = -0.192$ $E_b = 16.6951$

Excitation functions and cross sections have been measured for $E_d = 0.29$ to 7 MeV [see (1974AJ01, 1979AJ01, 1984AJ01)] and 0.60 to 0.95 MeV (1983FI13). See also (1983SZZY, 1986AB04). Resonances are reported at $E_d = 0.360(3)$ [< 0.5], $0.776(7)$ [250], $1.027(7)$ [60], 2.0 [broad], $2.375(50)$, $3.220(50)$ [400 ± 100] and ≈ 4.8 MeV [Γ_{lab} in keV] corresponding to ${}^9\text{Be}^*(16.975)$ [see also Table 9.4], 17.298 , 17.493 , (18.5) , 18.54 , 19.20 , 20.4): for references see Tables 9.3 in (1979AJ01, 1984AJ01). The total cross section at the $E_d = 0.78$ MeV resonance is important because it serves as normalization for the ${}^7\text{Be}(p, \gamma){}^8\text{B}$ reaction: the “best” value suggested by (1983FI13) is 157 ± 10 mb. See also (1986BA38) and (1974AJ01, 1984AJ01) for the earlier values. At $E({}^7\text{Li}) = 12.2 \pm 1.3$ MeV [corresponding to $E_d = 3.5$ MeV] the cross section is reported to be 155 ± 20 mb (1985HA40).

7. ${}^7\text{Li}(d, d){}^7\text{Li}$ $E_b = 16.6951$

The elastic scattering [$E_d = 0.4$ to 1.8 MeV] shows a marked increase in cross section for $E_d = 0.8$ to 1.0 MeV (perhaps related to ${}^9\text{Be}^*(17.30)$) and a conspicuous anomaly at $E_d = 1.0$ MeV, due to p-wave deuterons [${}^9\text{Be}^*(17.50)$]. The elastic scattering has also been studied for $E_d = 1.0$ to 2.6 MeV and 10.0 to 12.0 MeV: see (1979AJ01).

8. ${}^7\text{Li}(d, t){}^6\text{Li}$ $Q_m = -0.993$ $E_b = 16.6951$

Table 9.4: Parameters of the second $T = \frac{3}{2}$ state in ${}^9\text{Be}$, $J^\pi = \frac{1}{2}^-$ ^a

| | |
|---------------------------------------|-----------------------------|
| E_x (keV) | 16975.2 ± 0.8 |
| $\Gamma_{\text{c.m.}}$ (eV) | 490 ± 50 |
| Γ_γ (eV) ^b | 23.4 ± 1.7 |
| Γ_{γ_0} (eV) | 16.6 ± 1.2 ^c |
| Γ_{γ_1} (eV) ^b | 2.0 ± 0.2 |
| Γ_{γ_2} (eV) ^b | 0.55 ± 0.12 |
| Γ_{γ_3} (eV) ^b | 2.2 ± 0.7 |
| Γ_{γ_4} (eV) ^b | < 0.8 |
| Γ_{γ_5} (eV) ^b | 2.2 ± 0.3 |
| Γ_n (eV) ^b | < 380 ^d |
| Γ_{n_0} (eV) ^b | ≈ 35 |
| Γ_p (eV) ^b | ≈ 12 |
| Γ_d (eV) | 86 ± 18 |
| Γ_α (eV) ^b | < 350 ^d |

^a (1987ZI01) and C. van der Leun, private communication. See also (1986BE33).

^b Deduced from present results and older work: see Table 3 in (1987ZI01).

^c See also Table 9.8.

^d $\Gamma_\alpha + \Gamma_n = 380 \pm 50$ eV.

The cross section rises steeply from threshold to 95 mb at $E_d = 2.4$ MeV and then more slowly to ≈ 165 mb at $E_d = 4.1$ MeV. The t_0 yield curve ($\theta_{\text{lab}} = 155^\circ$) decreases monotonically for $E_d = 10.0$ to 12.0 MeV: see (1974AJ01).

9. ${}^7\text{Li}({}^3\text{He}, \text{p}){}^9\text{Be}$

$$Q_m = 11.2016$$

Observed proton groups are displayed in Table 9.5. The parameters for the particle and γ -decay of observed states are displayed in Tables 9.6 and 9.3. Angular distributions have been reported in the range $E({}^3\text{He}) = 0.9$ to 14 MeV [see (1974AJ01, 1979AJ01)] and at $E({}^3\vec{\text{He}}) = 14$ and 33 MeV (1983LE17, 1983RO22; p_0). See also ${}^{10}\text{B}$, (1984ME11) and (1986SC35; applications).

10. ${}^7\text{Li}(\alpha, \text{d}){}^9\text{Be}$

$$Q_m = -7.1516$$

Table 9.5: Excited states of ${}^9\text{Be}$ from ${}^7\text{Li}({}^3\text{He}, \text{p}){}^9\text{Be}$ ^a

| E_x (MeV \pm keV) | $\Gamma_{\text{c.m.}}$ (keV) |
|-----------------------------|------------------------------|
| 1.64 | |
| 2.4292 ± 1.7 | < 8 |
| 2.9 ± 250 | 1000 ± 250 |
| 3.076 ± 15 | 289 ± 22 |
| 4.704 ± 25 | 743 ± 55 |
| 6.7 ± 100 | 2000 ± 200 |
| 11.29 ± 30 | 620 ± 70 |
| 11.81 ± 20 | 400 ± 30 |
| 13.78 ± 30 | 590 ± 60 |
| 14.396 ± 5 ^b | 0.38 ± 0.03 |
| 16.671 ± 8 | 41 ± 4 |

^a See also Tables 9.4 in (1974AJ01, 1979AJ01) for references.

^b See also Table 9.3.

Angular distributions of d_0 , d_1 and d_2 have been reported at $E_\alpha = 30$ MeV: see (1974AJ01). See also (1983BE51; theor.).

11. ${}^7\text{Li}({}^6\text{Li}, \alpha){}^9\text{Be}$ $Q_m = 15.220$

Angular distributions of the α -groups to ${}^9\text{Be}^*(0, 2.43, 6.76)$ have been measured at $E({}^7\text{Li}) = 78$ MeV (1986GLZV: prelim.). For the excitation of ${}^4\text{He}^*$ see (1987GLZX; prelim.; $E({}^6\text{Li}) = 93$ MeV). For the earlier work see (1974AJ01).

12. ${}^9\text{Li}(\beta^-){}^9\text{Be}$ $Q_m = 13.606$

${}^9\text{Li}$ decays by β^- emission with $\tau_{1/2} = 178.3 \pm 0.4$ msec to several ${}^9\text{Be}$ states: see ${}^9\text{Li}$, reaction 1 and Table 9.7. Measurements of β - α coincidences involving ${}^9\text{Be}^*(11.28)$ show contributions from the direct $n + 2\alpha$ breakup process as well as the sequential n -emission to ${}^8\text{Be}^*(3.0)[J^\pi = 2^+]$, followed by breakup into 2α . The branching ratio for the ${}^9\text{Be}^*(2.43) \rightarrow {}^8\text{Be}_{\text{g.s.}} + n$ decay is $(6.4 \pm 1.2)\%$. ${}^9\text{Be}^*(2.78)[J^\pi = \frac{1}{2}^-]$ decays mainly to ${}^8\text{Be}_{\text{g.s.}} + n$, presumably by p-wave neutron emission: see (1979AJ01, 1984AJ01) for references, and (1988MI03) for a discussion of the evidence.

Table 9.6: Neutron decay of ${}^9\text{Be}$ states ^a

| ${}^9\text{Be}$ state (MeV) | l_n | Decay (in %) to | | θ^2 (%) ^b |
|--------------------------------|-------|----------------------------|------------------------|-----------------------------|
| | | ${}^8\text{Be}(0)$ | ${}^8\text{Be}^*(3.0)$ | |
| 2.43 | 3 | 7.0 ± 1.0 ^a | | 2.1 ± 0.6 |
| 2.78 | 1 | mainly | | 0.48 ± 0.06 |
| 3.05 | 2 | 87 ± 13 | | 81 ± 13 |
| 4.70 | 2 | 13 ± 4 | | 6.0 ± 0.4 |
| 6.76 | 3 | ≤ 2 | | ≤ 6 |
| | 1 | | 55 ± 14 | 37 ± 10 |
| 11.28 | 1 | ≤ 2 | | ≤ 0.1 |
| | 1 | | 14 ± 4 | 0.93 ± 0.28 |
| | 3 | | | 4.0 ± 1.2 |
| 11.81 | 1 | ≤ 3 | | ≤ 0.1 |
| | 1 | | 12 ± 4 | 0.48 ± 0.16 |
| | 3 | | | 1.8 ± 0.6 |
| 14.39 ^c | | | | |

^a For references see Table 9.5 in (1979AJ01).

^b Expressed in units of $\hbar^2/mR^2 = 2.47$ MeV.

^c See Table 9.3.

13. (a) ${}^9\text{Be}(\gamma, n){}^8\text{Be}$ $Q_m = -1.6654$
 (b) ${}^9\text{Be}(\gamma, \alpha){}^5\text{He}$ $Q_m = -2.47$
 (c) ${}^9\text{Be}(\gamma, n)2\ {}^4\text{He}$ $Q_m = -1.5735$

The photoneutron cross section has been measured from threshold to 320 MeV: see Table 9.6 in (1966LA04), (1979AJ01) and (1988DI02). A pronounced peak occurs ≈ 29 keV above threshold with $\sigma_{\text{max}} = 1.33 \pm 0.24$ mb. The shape of the resonance has been measured very accurately for $E_\gamma = 1675$ to 2168 keV. The FWHM of the peak is estimated to be 100 keV (1982FU11). See also (1983BA52; theor.) and (1987KU05). The cross section then decreases slowly to 1.2 mb at 40 keV above threshold. From bremsstrahlung studies, peaks in the (γ, Tn) cross section are observed corresponding to $E_x = 1.80$ and 3.03 MeV. At higher energies, using monoenergetic photons, the (γ, Tn) cross section is found to be relatively smooth from $E_\gamma = 17$ to 37 MeV with weak structures which correspond to $E_x = 17.1, 18.8, 19.9, 21.4, 22.4, 23.8$ [± 0.2] MeV and 27 ± 0.5 MeV (broad). In the range $E_\gamma = 18$ to 26 MeV the integrated (γ, n_0) cross section is < 0.1 MeV \cdot mb, that for $(\gamma, n_1) = 2.4 \pm 0.4$ MeV \cdot mb and the combined integrated cross section

Table 9.7: Branching parameters in ${}^9\text{Li}$ β -decay ^a

| E_x in ${}^9\text{Be}$ (MeV) | $J^\pi; T$ | Branching ratio (%) | $\log ft$ ^b |
|-----------------------------------|--|---------------------------|------------------------|
| 0 | $\frac{3}{2}^-; \frac{1}{2}$ | 50.5 ± 5 ^d | 5.31 |
| 2.43 | $\frac{5}{2}^-; \frac{1}{2}$ | 34 ± 4 | 5.07 |
| 2.78 ^c | $\frac{1}{2}^-; \frac{1}{2}$ | 10 ± 2 | 5.54 |
| 7.94 | $(\frac{1}{2}^-)$ ^e ; $\frac{1}{2}$ | 1.5 ± 0.5 | 5.04 |
| 11.28 | $(\frac{3}{2}^-)$ ^e ; $\frac{1}{2}$ | 4 ± 0.5 | 2.87 ^a |
| 11.81 | | < 0.1 | > 4.0 |

^a See Table 9.7 in (1984AJ01) for references.

^b M. J. Martin, private communication.

^c 2.78 ± 0.12 MeV, $\Gamma_{\text{c.m.}} = 1.10 \pm 0.12$ MeV; $\theta_p^2 = 0.48 \pm 0.06$: see Table 9.7 in (1979AJ01).

^d $P_n = (49.5 \pm 5)\%$.

^e Suggested on the basis of the branching ratios. These should be remeasured [see the ${}^9\text{C}(\beta^+)$ work of (1988MI03): reaction 9, in ${}^9\text{B}$]. F.C. Barker (private communication) suggests, on the basis of analog evidence, $J^\pi = (\frac{9}{2}, \frac{7}{2})^-$ for ${}^9\text{Be}^*(11.28)$.

for (γ, n) to ${}^8\text{Be}^*(16.6)$ and (γ, α_0) to ${}^5\text{He}_{\text{g.s.}}$ is 13.1 ± 2 MeV \cdot mb.

The total absorption cross section has been measured for $E_\gamma = 10$ to 210 MeV: it rises to ≈ 5 mb at ≈ 21 MeV, decreases to about 0 at 160 MeV and then increases to ≈ 1.5 mb at 210 MeV. An integrated cross section of 156 ± 15 MeV \cdot mb is reported for $E_\gamma = 10$ to 29 MeV as is resonant structure at $E_\gamma = 11.8, (13.5), 14.8, (17.3), (19.5), 21.0, (23.0),$ and (25.0) MeV. Fine structure is also reported at $E_\gamma = 20.47 \pm 0.04$ and 20.73 ± 0.04 MeV. See (1979AJ01) for references. At $E_\gamma = 1.58$ MeV, the cross section for reaction (c) is 0.40 ± 0.18 μb (1983FU13). For the electroproduction and photoproduction of helium nuclei for $E_e = 100$ to 225 MeV see (1986LI22). For hadron production at high energies see (1983AR24). See also (1987GO1Q), (1982DR08; applications), (1983FR1B, 1984GE1A, 1985AH06, 1985HA1H) and (1983BE45, 1983BO1B, 1983CA22, 1984KO33, 1985GO1A, 1985SH24, 1986JI01, 1987TE1E; theor.).

14. (a) ${}^9\text{Be}(\gamma, p){}^8\text{Li}$ $Q_m = -16.8869$
 (b) ${}^9\text{Be}(\gamma, np){}^7\text{Li}$ $Q_m = -18.9197$
 (c) ${}^9\text{Be}(\gamma, d){}^7\text{Li}$ $Q_m = -16.6951$
 (d) ${}^9\text{Be}(\gamma, t){}^6\text{Li}$ $Q_m = -17.6879$

The yield shows structure in the energy region corresponding to the ${}^9\text{Be}$ levels at 17–19 MeV followed by the giant resonance at $E_\gamma \approx 23$ MeV ($\sigma = 2.64 \pm 0.30$ mb). Structure attributed to eleven states of ${}^9\text{Be}$ with $18.2 < E_x < 32.2$ MeV has also been reported. Integrated cross sections have been obtained for each of these resonances, and over different energy intervals for protons leading to ${}^8\text{Li}^*(0 + 0.98, 2.26 + 3.21, 9.0, 17.0)$. Angular and energy distributions of photoprotons in various energy intervals have been studied by many groups: see (1974AJ01) for references. For momentum spectra of protons using tagged photons with $E_\gamma = 360 \rightarrow 600$ MeV, see (1984BA09). See also (1984AJ01) and (1984HO24).

The integrated cross sections are reported to be 1.0 ± 0.5 MeV · mb ($E_\gamma = 21 \rightarrow 33$ MeV) for reaction (c) to ${}^7\text{Li}^*(0 + 0.4)$ and 0.6 ± 0.3 MeV · mb ($E_\gamma = 25 \rightarrow 33$ MeV) for reaction (d) to ${}^6\text{Li}(0)$. The total integrated cross section for $[(\gamma, p) + (\gamma, pn) + (\gamma, d) + (\gamma, t)]$ is 33 ± 3 MeV · mb. Resonances in the (γ, d) and (γ, t) cross sections corresponding to ${}^9\text{Be}^*(26.0 \pm 0.2)$ and ${}^9\text{Be}^*(32.2 \pm 0.3)$, respectively, have been reported: see (1974AJ01). For momentum spectra of deuterons and tritons at $E_\gamma = 360 \rightarrow 600$ MeV see (1986BA07). Cross sections have been measured in the region of the $\Delta(1232)$ resonance by (1984HO09) $[(\gamma, pn), (\gamma, 2p)]$, (1987KA13) $[(\gamma, p), (\gamma, pn), (\gamma, 2p)]$ and (1986AR06) $[(\gamma, \pi^0)]$. For a high energy study of hadron production see (1983AR24). See also (1986MC1G), (1985HO27, 1985MA1G) and (1983TR04, 1986HO11, 1987LU1B; theor.).

15. ${}^9\text{Be}(\gamma, \gamma){}^9\text{Be}$

The second $T = \frac{3}{2}$ state of ${}^9\text{Be}$ at $E_x = 16.98$ MeV has been studied in this reaction: see Table 9.4 and reaction 4 (1987ZI01). See also (1986ZI01). With $E_{\text{bs}} = 31$ MeV eight resonances in (γ, γ') are reported for $17.4 < E_x < 29.4$ MeV (1984AL22).

16. (a) ${}^9\text{Be}(e, e){}^9\text{Be}$

| | |
|--|------------------|
| (b) ${}^9\text{Be}(e, \text{en}){}^8\text{Be}$ | $Q_m = -1.6654$ |
| (c) ${}^9\text{Be}(e, \text{ep}){}^8\text{Li}$ | $Q_m = -16.8869$ |
| (d) ${}^9\text{Be}(e, e\alpha){}^5\text{Li}$ | $Q_m = -2.47$ |

$$\langle r^2 \rangle^{1/2} = 2.519 \pm 0.012 \text{ fm}, \quad Q = 6.5_{-0.6}^{+0.9} \text{ fm}^2,$$

$$b = 1.5_{-0.2}^{+0.3} \text{ fm} [b=\text{oscillator parameter}]$$

$\langle r^2 \rangle_M^{1/2} = 3.2 \pm 0.3 \text{ fm}; \Omega = 6 \pm 2 \mu_N \cdot \text{fm}^2$ [this value of the magnetic octupole moment implies a deformation of the average nuclear potential].

The elastic scattering of electrons has been studied for E_e up to 700 MeV. Magnetic elastic scattering gives indications of both M1 and M3 contributions. Inelastic scattering populates a number of levels: see Table 9.8. At $E_e = 45$ and 49 MeV ${}^9\text{Be}^*(1.68)$ has a strongly asymmetric

line shape, as expected from its closeness to the ${}^8\text{Be}+n$ threshold. The form factor is dominated by a $0p_{3/2} \rightarrow 1s_{1/2}$ particle-hole transition. ${}^9\text{Be}^*(2.43)$ is strongly excited (1987KU05). Form factors have also been measured for ${}^9\text{Be}^*(0, 14.39, 16.67, 16.98, 17.49)$ by (1983LO11; $E_e = 100.0$ to 270.2 MeV). See also (1986MA48, 1987HY01, 1985HY1A). (1984WO09) suggest that the $T = \frac{1}{2}$ states [${}^9\text{Be}^*(16.67, 17.49)$] have $J^\pi = \frac{5}{2}^+$ and $\frac{7}{2}^+$, respectively, and that they have large parentage amplitudes with ${}^8\text{Be}^*(16.6+16.9)$ [$J^\pi = 2^+$], rather than with ${}^8\text{Be}_{g.s.}$. See (1974AJ01, 1979AJ01, 1984AJ01) for other work and earlier references.

Peaks are observed for the quasifree reaction and for the Δ -resonance at 72 ± 3 and 315 ± 20 MeV at $E_e = 537$ MeV, and at 115 ± 5 and 375 ± 10 MeV at $E_e = 730$ MeV. The FWHM widths for the quasifree reaction peaks are 80 ± 5 and 115 ± 5 MeV at $E_e = 537$ and 730 MeV (1984OC01, 1987OC01). For the deep inelastic cross sections at very high energies see (1984AR02). A parity-violation study using polarized 300 MeV electrons is reported by (1987OT1C; prelim.). See also (1984LI07, 1985LI15, 1986AC1A, 1986BA85, 1986LI1G), (1984DO20, 1985BE1K, 1985KI1A, 1987DE43, 1987FR1B, 1987HO1D, 1987HO1F) and (1983AL04, 1984CH20, 1984LI1E, 1986AZ01, 1986BE1L; theor.).

17. ${}^9\text{Be}(\pi^\pm, \pi^\pm){}^9\text{Be}$

The elastic scattering, and inelastic scattering to ${}^9\text{Be}^*(2.43, 6.76)$ have been studied at $E_{\pi^\pm} = 162$ and 291 MeV. Quadrupole contributions appear to be quite important for the elastic scattering at 162 MeV, but are much less so at the higher energy: see (1984AJ01) and the ‘‘General’’ section here.

18. (a) ${}^9\text{Be}(n, n){}^9\text{Be}$

(b) ${}^9\text{Be}(n, 2n){}^8\text{Be}$ $Q_m = -1.6654$

The population of ${}^9\text{Be}^*(0, 1.7, 2.4, 3.1, (6.8))$ has been reported in this reaction: see (1974AJ01). For the neutron decay of these states see Table 9.6. Angular distributions have been measured at $E_n = 3.5$ to 14.93 MeV [see (1974AJ01, 1979AJ01, 1984AJ01)], at $E_n = 7$ to 15 MeV (1983DA22; n_0), 11 to 17 MeV (1985TE01; n_0, n_2), 14.6 MeV (1985HA02, 1986HAYU; n_0) and 14.7 MeV (1984SH01; n_0, n_2) as well as at $E_n = 9$ to 17 MeV (1984BY03; n_0, n_2 ; see also for transition to ${}^9\text{Be}^*(6.76)$). See also ${}^{10}\text{Be}$, (1986MU07), (1986RO1H) and (1985BE59, 1985DI1B, 1985GU1D, 1987HAZS; theor.).

19. ${}^9\text{Be}(p, p){}^9\text{Be}$

Elastic and inelastic angular distributions have been studied at many energies in the range $E_p = 2.3$ to 1000 MeV [see (1974AJ01, 1979AJ01, 1984AJ01)], at $E_p = 2.31$ to 2.73 MeV (1983AL10;

Table 9.8: Levels of ${}^9\text{Be}$ from ${}^9\text{Be}(e, e'){}^9\text{Be}^*$ ^a

| E_x in ${}^9\text{Be}$ (MeV \pm keV) | $\Gamma_{\text{c.m.}}$ (keV) | Transition | J^π | Γ_{γ_0} (eV) |
|---|---------------------------------|-----------------|------------------------------|---|
| 1.684 ± 7 ^b | 217 ± 10 ^b | C1 | $\frac{1}{2}^+$ | 0.30 ± 0.12 |
| 2.44 ± 20 | < 30 | M1 | $\frac{5}{2}^-$ | 0.089 ± 0.010 |
| | | C2 | | $(1.89 \pm 0.14) \times 10^{-3}$ ^c |
| 3.04 ± 20 | 450 ± 150 | C1 ^d | $\frac{5}{2}^+$ ^d | 0.30 ± 0.25 ^e |
| 4.7 ± 200 | 700 ± 300 | C(1) | | 2.4 ± 1.2 ^f |
| 6.4 ± 100 | 1000 ± 300 | C2 | $\frac{7}{2}^-$ | 0.082 ± 0.035 |
| 13.84 ± 50 ^g | | | | |
| 14.388 ± 15 ^h | < 70 | M1 | $\frac{3}{2}^-$ | 6.9 ± 0.5 |
| 15.10 ± 50 ^g | | | | |
| 15.97 ± 30 ^g | ≈ 300 | M1 | | 3.7 ± 0.8 ^f |
| 16.631 ± 15 ^h | < 70 | M2 ⁱ | $\leq \frac{7}{2}^+$ | 0.26 ± 0.02 ^f |
| | | M1 | $\leq \frac{5}{2}^-$ | 2.0 ± 0.5 ^f |
| 16.961 ± 15 ^h | < 70 | M1 | $\frac{1}{2}^-$ | 11.5 ± 1.4 |
| 17.28 | | M1 | $\leq \frac{5}{2}^-$ | 7.3 ± 1.3 ^f |
| 17.480 ± 20 ^h | ≈ 100 | M2 ⁱ | $\leq \frac{7}{2}^+$ | 0.40 ± 0.03 ^f |
| 18.02 ± 50 ^g | | | | |
| 18.62 ± 50 ^g | | | | |
| 19.51 ± 50 ^g | | | | |
| 20.76 ± 50 ^g | | | | |
| j | | | | |

^a For references see Table 9.8 in (1979AJ01). See also (1984AJ01).

^b $B(\text{C1})\uparrow = 0.027 \pm 0.002 e^2 \cdot \text{fm}^2$ and $B(\text{M2})\uparrow = 8.8 \pm 1.5 \mu_N^2 \cdot \text{fm}^2$ (1987KU05).

^c $B(\text{C2}, \omega)\uparrow = 45.7 \pm 3.5 e^2 \cdot \text{fm}^4$.

^d Assumed.

^e The group may consist of two unresolved states, the second one reached by an M1 transition [$J^\pi = (\frac{1}{2})^-$] with $\Gamma_{\gamma_0} = 0.18 \pm 0.09$ eV. I am indebted to Dr. L.W. Fagg for his help in understanding this point.

^f $g\Gamma_{\gamma_0}$; where $g = (2J_f + 1)/(2J_i + 1)$.

^g Weak transition.

^h (1983LO11).

ⁱ Or pure spin-flip E1. (1984WO09) assign $J^\pi = \frac{5}{2}^+$ and $\frac{7}{2}^+$, respectively, for ${}^9\text{Be}^*(16.67, 17.49)$.

^j See (1974AJ01, 1984AJ01) for states reported at higher excitation energies.

p_0), 11 to 17 MeV (1986MU07; p_0) and 1 GeV (1985AL16; p_0) as well as at $E_{\bar{p}} = 200$ MeV (1985GLZZ; p_0 ; prelim.) and 220 MeV (1985RO15; p_0, p_2). The elastic distributions show pronounced diffraction maxima. A quadrupole-deformed optical-model potential is necessary to obtain a good fit to the p_0 and p_2 angular distributions: see (1974AJ01). The spin-flip probability at $E_{\bar{p}} = 31$ MeV is ≈ 0 for the p_2 group, which is expected in view of the collective nature of the transition (1981CO08).

The structure corresponding to ${}^9\text{Be}^*(1.7)$ is asymmetric, as expected: see reaction 16 and Table 9.8 for its parameters. [At $E_p = 13$ MeV the spectra are dominated by ${}^9\text{Be}^*(2.43)$ (1987KU05)]. The weighted mean of the values of E_x for ${}^9\text{Be}^*(2.4)$ listed in (1974AJ01) is 2432 ± 3 keV. ${}^9\text{Be}^*(3.1)$ has $E_x = 3.03 \pm 0.03$ MeV, $\Gamma = 250 \pm 50$ keV, $J^\pi = \frac{3}{2}^+, \frac{5}{2}^+$. Higher states are observed at $E_x = 4.8 \pm 0.2, 6.76 \pm 0.06$ [$J^\pi = \frac{1}{2}^+, \frac{5}{2}^+, \frac{7}{2}^+$ (but see below), $\Gamma = 1.2 \pm 0.2$ MeV], 7.94 ± 0.08 ($\Gamma \approx 1$ MeV), 11.3 ± 0.2 MeV ($\Gamma \approx 1$ MeV), 14.4 ± 0.3 ($\Gamma \approx 1$ MeV), $16.7 \pm 0.3, 17.4 \pm 0.3, 19.0 \pm 0.4, 21.1 \pm 0.5$ and 22.4 ± 0.7 MeV [the five highest states are all broad]. For ${}^9\text{Be}^*(2.4, 6.8)$

$B(E2\uparrow) = 49 \pm 6$ and 24 ± 4 fm⁴ and $\Gamma(E2\downarrow) = 0.0025$ and 0.10 eV, respectively. The strong population of ${}^9\text{Be}^*(2.4, 6.8)$ is consistent with the assumption that they have $J^\pi = \frac{5}{2}^-$ and $\frac{7}{2}^-$, respectively, and are members of the ground state $K = \frac{3}{2}^-$ band. See (1966LA04, 1974AJ01) for references. For K^+ production see (1986AB07). See also ${}^{10}\text{B}$, (1982BE1E), (1986MU07, 1986RO1H) and (1984SH1K, 1985GU1D, 1986BE1L, 1986NA15, 1987CU01, 1987HA01; theor.).

| | |
|---|------------------|
| 20. (a) ${}^9\text{Be}(p, 2p){}^8\text{Li}$ | $Q_m = -16.8869$ |
| (b) ${}^9\text{Be}(p, pd){}^7\text{Li}$ | $Q_m = -16.6951$ |
| (c) ${}^9\text{Be}(p, pn){}^8\text{Be}$ | $Q_m = -1.6654$ |
| (d) ${}^9\text{Be}(p, pt){}^6\text{Li}$ | $Q_m = -17.6879$ |
| (e) ${}^9\text{Be}(p, p^3\text{He}){}^6\text{He}$ | $Q_m = -21.176$ |
| (f) ${}^9\text{Be}(p, p\alpha){}^5\text{He}$ | $Q_m = -2.47$ |

The reactions $(p, 2p)X$ and $(p, pd)X$ have been studied at $E_p = 300$ MeV (1983GR21, 1984HE03). For reactions (a) and (c) see also ${}^8\text{Li}, {}^8\text{Be}$ (1985BE30, 1985DO16; 1 GeV) and (1984AJ01). Reaction (c) at $E_p = 10 - 24$ MeV involves ${}^9\text{Be}^*(3.0, 4.7)$: see (1984AJ01). See also (1984WA21). For reactions (b) and (d) at $E_p = 58$ MeV see ${}^7\text{Li}, {}^6\text{Li}$ and (1985DE17, 1984DE1F). For reactions (e) and (f) see (1985PAZL; $E_{\bar{p}} = 70$ MeV). The $(p, p\alpha)$ process (reaction (f)) has been studied at $E_p = 150.5$ MeV (1985WA13; see for S_α). For inclusive proton spectra yields see (1985SE15). See also (1983AN18, 1987BO1N), (1986CH1J) and (1983KA1A, 1984KO1E, 1985BO1A, 1985GA1A, 1985VD03, 1986ER1A, 1986OS08, 1987HA01; theor.).

21. ${}^9\text{Be}(d, d){}^9\text{Be}$

Angular distributions have been measured in the range 1.0 to 410 MeV [see (1974AJ01, 1979AJ01, 1984AJ01)] and at $E_d = 2.0$ to 2.8 MeV (1983DE50, 1984AN16). See also ^{11}B in (1990AJ01).

Inelastic groups have been reported to $^9\text{Be}^*(1.7, 4.7, 6.8)$ and to states with $E_x = 2431.9 \pm 7.0$ keV and 3040 ± 15 keV ($\Gamma = 294 \pm 20$ keV): see (1974AJ01).

22. (a) $^9\text{Be}(t, t)^9\text{Be}$

(b) $^9\text{Be}(t, nt)^8\text{Be}$ $Q_m = -1.6654$

Angular distributions of elastically scattered tritons have been measured at $E_t = 2.10$ MeV and at $E_{\bar{t}} = 15$ and 17 MeV: see (1974AJ01, 1984AJ01). Reaction (b) at 4.2 and 4.6 MeV proceeds via $^9\text{Be}^*(2.4)$: see (1974AJ01).

23. (a) $^9\text{Be}(^3\text{He}, ^3\text{He})^9\text{Be}$

(b) $^9\text{Be}(^3\text{He}, 2\alpha)^4\text{He}$ $Q_m = 19.0043$

Angular distributions have been studied for $E(^3\text{He}) = 1.6$ to 46.1 MeV and at 217 MeV [see (1974AJ01, 1979AJ01, 1984AJ01)]. At $E(^3\text{He}) = 39.8$ MeV, $^9\text{Be}^*(1.7, 2.4, 3.1, 4.7, 6.8, 14.4)$ are populated.

Reaction (b) has been studied in a kinematically complete experiment for $E(^3\text{He}) = 3$ to 12 MeV (1986LA26) and 11.9 to 24.0 MeV (1987WA25). For the earlier work see (1984AJ01). See also (1987TR01; theor.).

24. (a) $^9\text{Be}(\alpha, \alpha)^9\text{Be}$

(b) $^9\text{Be}(\alpha, 2\alpha)^5\text{He}$ $Q_m = -2.47$

Angular distributions have been studied at many energies in the range $E_\alpha = 5.0$ to 104 MeV [see (1974AJ01, 1984AJ01)] and $E_\alpha = 23.1$ MeV (1984HU1D, 1985HU1B; α_0, α_2). At $E_\alpha = 35.5$ MeV, states belonging to the $K = \frac{3}{2}^-$ ground-state band are strongly excited [$^9\text{Be}^*(0, 2.43, 6.76, 11.28)$]; it is suggested that the latter has $J^\pi = (\frac{9}{2}^-)$; see, however, reaction 12]. The first three states belonging to the $K = \frac{1}{2}^+$ band are also excited [$^9\text{Be}^*(1.68, 3.05, 4.70)$] (1982PE03; coupled channels analysis). For reaction (b) see (1983ZH09; 18 MeV); $S_\alpha = 0.96$ [see (1984AJ01)] and (1987WA25; $E(^3\text{He}) = 12$ to 24 MeV). See also ^8Be , (1987BU27, 1987KO1K) and (1984LI28, 1985SR01; theor.).

25. (a) $^9\text{Be}(^6\text{Li}, ^6\text{Li})^9\text{Be}$

(b) $^9\text{Be}(^7\text{Li}, ^7\text{Li})^9\text{Be}$

Elastic angular distributions have been measured at $E(^6\text{Li}) = 4, 6$ and 24 MeV and at $E(^7\text{Li}) = 24$ and 34 MeV [see (1979AJ01)] as well as at $E(^6\text{Li}) = 32$ MeV (1985CO09; also to $^9\text{Be}^*(2.43)$) and 50 MeV (1988TRZY; prelim.) and $E(^7\text{Li}) = 78$ MeV (1986GLZV, 1986GLZU; also to $^9\text{Be}^*(2.43, 6.76)$). For the interaction cross section at $E(\text{Li}) = 790$ MeV/A see (1985TA18).

26. $^9\text{Be}(^9\text{Be}, ^9\text{Be})^9\text{Be}$

Elastic angular distributions have been obtained at $E(^9\text{Be}) = 5$ to 26 MeV [see (1979AJ01, 1984AJ01)] and at 35 to 50 MeV (1984OM02; also to $^9\text{Be}^*(2.43)$). See also (1985JA09). For yields and cross sections see (1984OM03, 1986CU02). For the interaction cross section at $E(^9\text{Be}) = 790$ MeV/A see (1985TA18).

27. (a) $^9\text{Be}(^{10}\text{B}, ^{10}\text{B})^9\text{Be}$ (b) $^9\text{Be}(^{11}\text{B}, ^{11}\text{B})^9\text{Be}$

Elastic angular distributions have been reported at $E(^{10}\text{B}) = 20.1$ and 30.0 MeV (1983SR01). For yields and cross section measurements see (1983SR01, 1984DA17, 1986CU02). See also (1983DU13) and (1984IN03, 1986RO12; theor.).

28. (a) $^9\text{Be}(^{12}\text{C}, ^{12}\text{C})^9\text{Be}$ (b) $^9\text{Be}(^{13}\text{C}, ^{13}\text{C})^9\text{Be}$

Elastic angular distributions have been measured for reaction (a) at $E(^{12}\text{C}) = 12, 15, 18$ and 21 MeV and $E(^9\text{Be}) = 14$ to 76.6 MeV [see (1979AJ01, 1984AJ01)] and 158.3 MeV (1984FU10) as well as at $E(^{12}\text{C}) = 65$ MeV (1985GO1H; prelim.; various ^{12}C states). For yield and fusion cross-section measurements see (1983JA09, 1985DE22) and (1984AJ01). Elastic angular distributions for reaction (b) are reported at $E(^9\text{Be}) = 14$ to 26 MeV: see (1984AJ01). For yield measurements see (1984DA17, 1986CU02). See also (1983DU13, 1984FR1A, 1984HA53, 1985BE1A, 1985CU1A) and (1982GU21, 1983KA17, 1983OH04, 1983SA20, 1984HA43, 1986BA69, 1986HA13, 1986KA22, 1986MI24; theor.).

29. $^9\text{Be}(^{14}\text{N}, ^{14}\text{N})^9\text{Be}$

Elastic angular distributions have been measured at $E(^{14}\text{N}) = 25$ and 27.3 MeV: see (1974AJ01). For a fusion study see (1984MA28).

30. (a) ${}^9\text{Be}({}^{16}\text{O}, {}^{16}\text{O}){}^9\text{Be}$
 (b) ${}^9\text{Be}({}^{18}\text{O}, {}^{18}\text{O}){}^9\text{Be}$

Elastic angular distributions have been reported in the range $E({}^{16}\text{O}) = 15$ to 30 MeV [see (1979AJ01)], at $E({}^9\text{Be}) = 14, 20$ and 26 MeV [see (1984AJ01)], 43 MeV (1985WI18) and 157.7 MeV (1984FU10), as well as at $E({}^{18}\text{O}) = 12.1, 16$ and 20 MeV [see (1974AJ01)]. See also (1983BI13, 1983DA10, 1985BE1A, 1985CU1A) and (1982GU21, 1983GR18, 1983SA20, 1984HA43, 1988PO1D; theor.).

31. (a) ${}^9\text{Be}({}^{20}\text{Ne}, {}^{20}\text{Ne}){}^9\text{Be}$
 (b) ${}^9\text{Be}({}^{24}\text{Mg}, {}^{24}\text{Mg}){}^9\text{Be}$
 (c) ${}^9\text{Be}({}^{26}\text{Mg}, {}^{26}\text{Mg}){}^9\text{Be}$
 (d) ${}^9\text{Be}({}^{27}\text{Al}, {}^{27}\text{Al}){}^9\text{Be}$
 (e) ${}^9\text{Be}({}^{28}\text{Si}, {}^{28}\text{Si}){}^9\text{Be}$
 (f) ${}^9\text{Be}({}^{39}\text{K}, {}^{39}\text{K}){}^9\text{Be}$
 (g) ${}^9\text{Be}({}^{40}\text{Ca}, {}^{40}\text{Ca}){}^9\text{Be}$
 (h) ${}^9\text{Be}({}^{44}\text{Ca}, {}^{44}\text{Ca}){}^9\text{Be}$

Elastic angular distributions have been measured for many of these reactions: see (1979AJ01, 1984AJ01). Recently they have been studied on ${}^{26}\text{Mg}$ and ${}^{40}\text{Ca}$ at $E({}^9\text{Be}) = 43$ and 45 MeV, respectively (1985WI18) and on ${}^{26}\text{Mg}, {}^{27}\text{Al}$ and ${}^{40}\text{Ca}$ at $E({}^9\text{Be}) = 158.1$ – 158.3 MeV (1984FU10). For pion production in reaction (a) see (1985FR13). The interaction cross section for 790 MeV/ A ${}^9\text{Be}$ on ${}^{27}\text{Al}$ has been measured by (1985TA18). Breakup measurements involving ${}^{40}\text{Ca}$ are reported by (1984GR20). See also (1983BI13, 1984FR1A, 1984HA53) and (1984GU09, 1985AN16, 1985BL18; theor.).

32. ${}^{10}\text{Be}(\text{d}, \text{t}){}^9\text{Be} \quad Q_{\text{m}} = -0.5547$

Forward angular distributions have been obtained at $E_{\text{d}} = 15.0$ MeV for the tritons to ${}^9\text{Be}^*(0, 1.7, 2.4, 3.1)$. The ground-state transition is well fitted by $l = 1$. The transition to ${}^9\text{Be}^*(1.7)$ [$\approx 165 \pm 25$ keV] is consistent with $J^{\pi} = \frac{1}{2}^+$, that to ${}^9\text{Be}^*(2.4)$ is quite well fitted with $l = 3$ [$J^{\pi} = \frac{5}{2}^-$], and that to ${}^9\text{Be}^*(3.1)$ [$\Gamma = 280 \pm 25$ keV] is consistent with $l = 2$. No other narrow states are seen up to $E_{\text{x}} = 5.5$ MeV: see (1974AJ01).

33. ${}^{10}\text{B}(\text{n}, \text{d}){}^9\text{Be} \quad Q_{\text{m}} = -4.3612$

See (1974AJ01) and ^{11}B in (1980AJ01).

$$34. \text{}^{10}\text{B}(\text{p}, 2\text{p})\text{}^9\text{Be} \quad Q_{\text{m}} = -6.5857$$

See (1974AJ01) and (1985BE30, 1985DO16).

$$35. \text{}^{10}\text{B}(\text{d}, \text{}^3\text{He})\text{}^9\text{Be} \quad Q_{\text{m}} = -1.0922$$

Angular distributions of the ^3He groups corresponding to $^9\text{Be}^*(0, 2.4)$ have been studied at $E_{\text{d}} = 11.8, 28$ and 52 MeV [the latter also to $^9\text{Be}^*(6.7)$], and at $E_{\text{d}} = 15$ MeV: $S = 0.72$ and 0.82 for $^9\text{Be}^*(0, 2.4)$. At $E_{\text{d}} = 52$ MeV $^9\text{Be}^*(11.3)$ appears to be strongly populated: see (1979AJ01).

$$36. \text{}^{10}\text{B}(\text{t}, \alpha)\text{}^9\text{Be} \quad Q_{\text{m}} = 13.2283$$

At $E_{\text{t}} = 12.9$ MeV α -groups are observed to the ground state of ^9Be and to excited states at $E_{\text{x}} = 1.75 \pm 0.03, 2.43, 3.02 \pm 0.04$ ($\Gamma = 320 \pm 60$ keV), 11.27 ± 0.04 ($\Gamma = 530 \pm 70$ keV), (14.4) [$\Gamma \approx 800$ keV], 14.39 and 16.67 MeV. The $T = \frac{3}{2}$ state $^9\text{Be}^*(14.39)$ is very weakly populated [$\approx 5\%$ of intensity of α_2]. The angular distribution of the α_2 group shows sharp forward and backward peaking. The α_0 group is not peaked in the backward direction: see (1979AJ01). See also (1984AJ01) and (1982CI1A; theor.).

$$37. \text{}^{11}\text{B}(\text{p}, \text{}^3\text{He})\text{}^9\text{Be} \quad Q_{\text{m}} = -10.3218$$

At $E_{\text{p}} = 45$ MeV angular distributions are reported for the ^3He ions corresponding to $^9\text{Be}^*(0, 2.4, 11.8, 13.8, 14.39)$ [$T = \frac{3}{2}$], 15.96 ± 0.04 [$T = \frac{1}{2}$]. In addition one or more states may be located at $^9\text{Be}^*(15.13)$. It is suggested that $^9\text{Be}^*(11.8, 13.8, 15.96)$ are the $J^{\pi} = \frac{3}{2}^{-}, T = \frac{1}{2}$ analogs to $^9\text{Be}^*(12.06, 14.01, 16.02)$. Angular distributions are also reported at $E_{\text{p}} = 40$ MeV. The intensity of the group to $^9\text{Be}^*(3.1)$ is $\approx 1\%$ of the ground-state group at that energy: see (1974AJ01). The excitation energy of the first $T = \frac{3}{2}$ state is $E_{\text{x}} = 14392.2 \pm 1.8$ keV (1974KA15), using Q_{m} .

$$38. \text{(a) } \text{}^{11}\text{B}(\text{d}, \alpha)\text{}^9\text{Be} \quad Q_{\text{m}} = 8.0314$$

$$\text{(b) } \text{}^{11}\text{B}(\text{d}, n\alpha)2 \text{}^4\text{He} \quad Q_{\text{m}} = 6.4579$$

Alpha groups are reported corresponding to ${}^9\text{Be}^*(0, 1.7, 2.4, 3.1)$. The width of ${}^9\text{Be}^*(1.7)$ [$E_x = 1.70 \pm 0.01$ MeV] is $\Gamma_{\text{c.m.}} = 220 \pm 20$ keV. The weighted mean of the values of E_x of ${}^9\text{Be}^*(2.4)$, reported in (1974AJ01), is 2425 ± 3 keV. The $\frac{5}{2}^+$ state is at $E_x = 3.035 \pm 0.025$ MeV: $\Gamma_{\text{c.m.}} = 257 \pm 25$ keV. The ratio Γ_γ/Γ of ${}^9\text{Be}^*(1.7) \leq 2.4 \times 10^{-5}$, that for ${}^9\text{Be}^*(2.4)$ is reported to be $(1.16 \pm 0.14) \times 10^{-4}$. Since Γ_γ is known from (e, e') [see Table 9.8: 0.089 ± 0.010 eV], $\Gamma = 0.77 \pm 0.15$ keV. See (1974AJ01, 1979AJ01) for references.

Angular distributions for α_0 and α_2 are reported at $E_d = 0.39$ to 3.9 MeV and at 12 MeV [see (1974AJ01, 1979AJ01)]. Reaction (b), at $E_d = 10.4$ and 12.0 MeV, proceeds via ${}^9\text{Be}^*(2.4)$ and to some extent via ${}^9\text{Be}^*(3.1, 4.7)$ and possibly some higher excited states. The dominant decay of ${}^9\text{Be}^*(2.4)$ is to ${}^5\text{He}(0) + \alpha$ while ${}^9\text{Be}^*(3.1, 4.7)$ decay to ${}^8\text{Be}(0) + n$. It should be noted, however, that the peaks corresponding to ${}^9\text{Be}^*(3.0)$ have a FWHM of ≈ 1 MeV, which may imply that ${}^9\text{Be}^*(2.8)$ is involved.

$$39. {}^{12}\text{C}(\gamma, \text{pd}){}^9\text{Be} \quad Q_m = -31.7726$$

See (1986BU22, 1987BU1A, 1987VO08).

$$40. \text{(a) } {}^{12}\text{C}(n, \alpha){}^9\text{Be} \quad Q_m = -5.7012$$

$$\text{(b) } {}^{12}\text{C}(n, n\alpha)2 {}^4\text{He} \quad Q_m = -7.2747$$

Angular distributions of the α_0 group have been measured at $E_n = 13.9$ to 18.8 MeV [see (1974AJ01)] and at 14.1 MeV (1984HA48). ${}^9\text{Be}^*(1.7, 2.4, 3.1, 6.8)$ are also populated. Reaction (b) at $E_n = 13$ to 18 MeV involves ${}^9\text{Be}^*(2.4)$. See (1984HA48) for differential cross sections at 14.1 MeV and for partial and total cross sections.

$$41. {}^{12}\text{C}(p, p^3\text{He}){}^9\text{Be} \quad Q_m = -26.2790$$

See (1985DE17; $E_p = 58$ MeV).

$$42. {}^{12}\text{C}(\alpha, {}^7\text{Be}){}^9\text{Be} \quad Q_m = -24.692$$

See ${}^7\text{Be}$.

$$43. \text{(a) } {}^{12}\text{C}({}^7\text{Li}, {}^{10}\text{B}){}^9\text{Be} \quad Q_m = -8.492$$

$$\text{(b) } {}^{12}\text{C}({}^{13}\text{C}, {}^{16}\text{O}){}^9\text{Be} \quad Q_m = -3.4856$$

$$\text{(c) } {}^{12}\text{C}({}^{14}\text{N}, {}^{17}\text{F}){}^9\text{Be} \quad Q_m = -10.4360$$

For reaction (a) see ¹⁰B. For reaction (b) see (1988KR11) and (1985OS06; theor.). For reaction (c) see (1986GO1B; $E(^{14}\text{N}) = 150$ MeV).

$$44. \ ^{13}\text{C}(^3\text{He}, ^7\text{Be})^9\text{Be} \quad Q_m = -9.060$$

Angular distributions have been obtained at $E(^3\text{He}) = 70$ MeV for the transitions to ⁹Be*(0, 2.4) and ⁷Be*(0, 0.43). Broad states at 2.9, 4.8 ± 0.2 , 7.3 ± 0.2 and 11.9 ± 0.4 MeV are also populated: see (1979AJ01).

$$45. \ ^{13}\text{C}(\alpha, ^8\text{Be})^9\text{Be} \quad Q_m = -10.7395$$

See ⁸Be here and ⁹Be in (1979AJ01).

$$46. \ ^{14}\text{N}(^7\text{Li}, ^{12}\text{C})^9\text{Be} \quad Q_m = 6.423$$

See (1986GO1B; $E(^{14}\text{N}) = 150$ MeV).

$$47. \ ^{16}\text{O}(\alpha, ^{11}\text{C})^9\text{Be} \quad Q_m = -24.310$$

See (1987KW01, 1987KW03; theor.).

$$48. \ ^{16}\text{O}(^{13}\text{C}, ^{20}\text{Ne})^9\text{Be} \quad Q_m = -5.912$$

See ²⁰Ne in (1987AJ02). See also (1985KA1J).

⁹B
(Figs. 3 and 4)

GENERAL: See also (1984AJ01).

Model calculations: (1983SH38, 1987VOZU).

Special states: (1983AU1B, 1983FE07, 1983GO28, 1984KO40, 1985PO18, 1985PO19, 1985SH24, 1986AN07, 1987BA54, 1987VOZU).

Complex reactions involving ⁹B: (1985PO18, 1985PO19, 1987AR19, 1987PO03).

Reactions involving pions: (1985PN01).

Hypernuclei: (1982KA1D, 1983KO1D, 1983SH38, 1983SH1E, 1984ZH1B, 1985AH1A, 1985PN01, 1986DA1B, 1986KO1A, 1987BO1L, 1987MI38, 1987PO1H).

Other topics: (1985AN28, 1985SH24).

Ground state of ⁹B: (1983ANZQ, 1983AU1B, 1985AN28).

| | | |
|--|-----------------|----------------|
| 1. (a) ${}^6\text{Li}({}^3\text{He}, \gamma){}^9\text{B}$ | $Q_m = 16.601$ | |
| (b) ${}^6\text{Li}({}^3\text{He}, n){}^8\text{B}$ | $Q_m = -1.975$ | $E_b = 16.601$ |
| (c) ${}^6\text{Li}({}^3\text{He}, p){}^8\text{Be}$ | $Q_m = 16.7863$ | |
| (d) ${}^6\text{Li}({}^3\text{He}, d){}^7\text{Be}$ | $Q_m = 0.112$ | |
| (e) ${}^6\text{Li}({}^3\text{He}, t){}^6\text{Be}$ | $Q_m = -4.307$ | |
| (f) ${}^6\text{Li}({}^3\text{He}, {}^3\text{He}){}^6\text{Li}$ | | |
| (g) ${}^6\text{Li}({}^3\text{He}, \alpha){}^5\text{Li}$ | $Q_m = 14.91$ | |

The 90° yields of γ_0 and of γ to ${}^9\text{B}^*(2.36)$ (reaction (a)) have been measured for $E({}^3\text{He}) = 0.6$ to 1.2 MeV [as have the 2α -particles from the decay of ${}^8\text{Be}^*(16.6)$ (reaction (c))]: they are reported to show a resonance at $E({}^3\text{He}) = 765 \pm 5$ keV [${}^9\text{B}^*(17.111)$], attributed to ${}^9\text{B}^*(17.076)$ [$T = \frac{3}{2}$]. The total cross section for reaction (b) increases monotonically from threshold to ≈ 7 mb at 3.8 MeV. It then decreases monotonically from $E({}^3\text{He}) = 5.5$ to 7.6 MeV and also from 8.9 to 26.5 MeV: see (1979AJ01, 1984AJ01), and ${}^8\text{B}$.

Absolute cross sections for protons (reaction (c)) to ${}^8\text{Be}^*(0, 2.9, 16.6, 16.9)$ as well as for the continuum protons have been measured for $E({}^3\text{He}) = 0.5$ to 1.85 MeV. Reaction rate parameters, $\langle\sigma v\rangle$, have been calculated for $kT = 0.01$ to 10.0 MeV. Excitation functions for p_0 and p_1 have been measured for $E({}^3\text{He}) = 0.9$ to 17 MeV, and polarization measurements are reported at $E({}^3\text{He}) = 14$ MeV. Resonances are observed at $E({}^3\text{He}) = 1.6$ and 3.0 MeV [$\Gamma = 0.25$ and 1.5 MeV]: see (1974AJ01, 1979AJ01), and ${}^8\text{Be}$. Polarization measurements are also reported at $E({}^6\bar{\text{Li}}) = 21$ MeV (VAP; p_0). In the range $E({}^3\text{He}) = 0.7$ to 2.0 MeV, a resonance in the excitation function for deuterons (reaction (d)) is reported corresponding to ${}^9\text{B}^*(17.6)$. Polarization

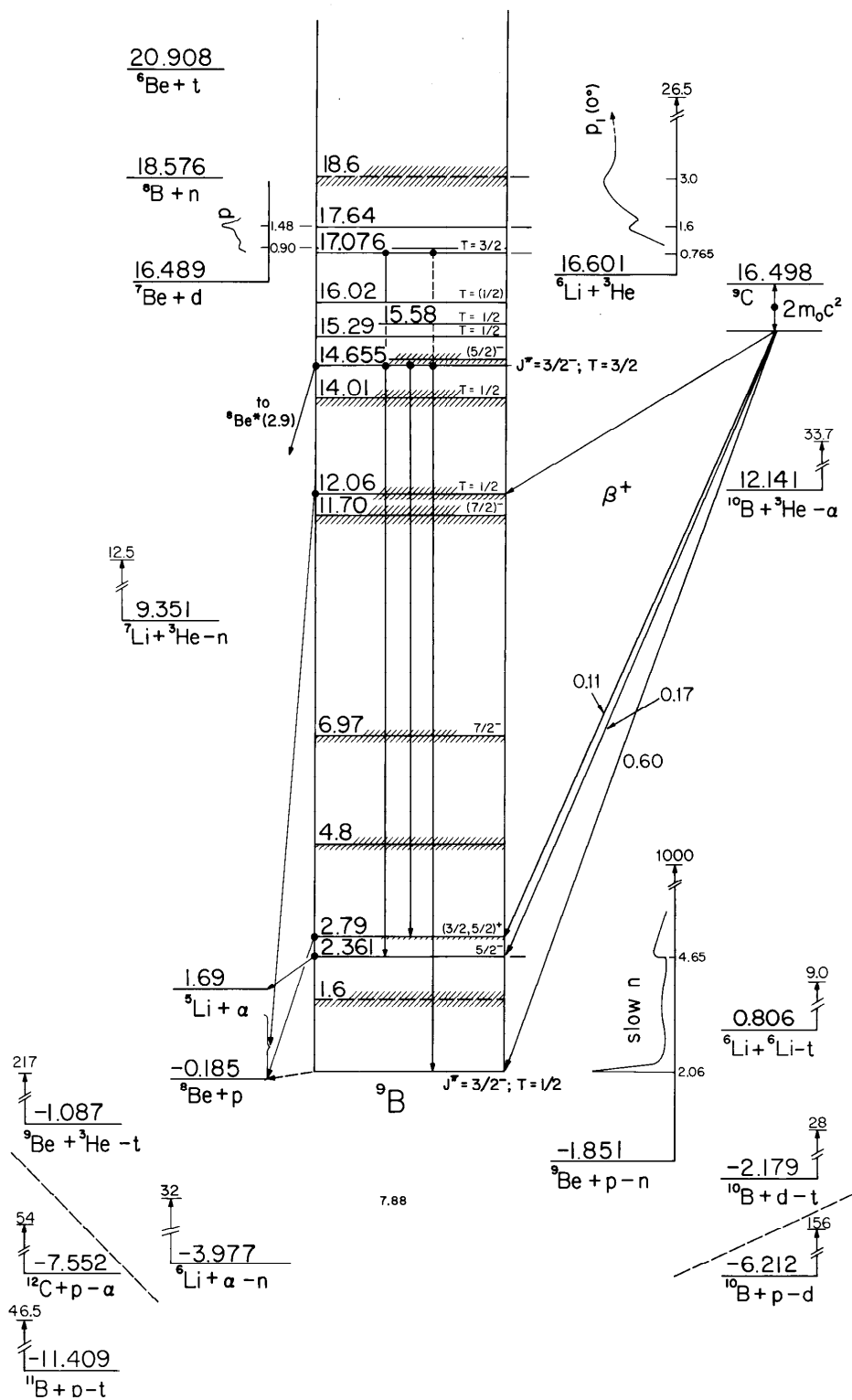

Fig. 3: Energy levels of ${}^9\text{B}$. For notation see Fig. 1.

measurements at $E(^3\vec{\text{He}}) = 33.3$ MeV for the d_0 and d_1 groups are reported. Excitation functions for t_0 (reaction (e)) have been measured for $E(^3\text{He}) = 10$ to 16 and 23.3 to 25.4 MeV: see (1974AJ01). Polarization measurements are reported at $E(^3\vec{\text{He}}) = 33.3$ MeV for the t_0 group as well as for the ^3He ions to $^6\text{Li}^*(0, 2.19)$ (reaction (f)). The elastic scattering has also been studied for $E(^3\text{He}) = 0.7$ to 2.0 MeV. The α - α coincidences ($^5\text{Li}_{\text{g.s.}}$ decay) (reaction (g)) have been measured for $E(^3\text{He}) = 1.4$ to 1.8 MeV: a resonance is observed at 1.57 ± 0.02 MeV [$^9\text{B}^*(17.63)$], $\Gamma = 70 \pm 20$ keV. Polarization measurements of the α -particles to $^5\text{Li}^*(0, 16.7)$ are reported at $E(^3\vec{\text{He}}) = 33.3$ MeV. For a study of the $(^3\text{He}, p\alpha)^4\text{He}$ reaction at 3.5, 4.4 and 5.5 MeV see (1987ZA07). See (1979AJ01, 1984AJ01) for references.

$$2. \ ^6\text{Li}(\alpha, n)^9\text{B} \quad Q_{\text{m}} = -3.977$$

At $E_{\alpha} = 28$ and 32 MeV angular distributions have been measured to $^9\text{B}^*(0, 2.36)$ (1985GUZQ; prelim.). See also (1974AJ01).

$$3. \ ^6\text{Li}(^6\text{Li}, t)^9\text{B} \quad Q_{\text{m}} = 0.806$$

Angular distributions of the t_0 group have been measured for $E(^6\text{Li}) = 4.0$ to 5.5 MeV and at 7.35 and 9.0 MeV. No evidence was observed for a group corresponding to $^9\text{B}^*(1.6)$: see (1974AJ01).

$$4. \ ^7\text{Li}(^3\text{He}, n)^9\text{B} \quad Q_{\text{m}} = 9.351$$

For $E(^3\text{He})$ to 12.5 MeV this reaction populates $^9\text{B}^*(0, (1.6), 2.4, 2.8, (7.0))$, and states at $E_{\text{x}} = 4.8 \pm 0.1$ MeV [1.0 ± 0.2 MeV], 12.06 ± 0.06 [0.8 ± 0.2], 14.01 ± 0.07 [0.39 ± 0.11], 14.657 ± 0.005 (based on Q_{m}) [< 0.045], 16.024 ± 0.025 [0.180 ± 0.016], 17.19 and 17.63 MeV [Γ in brackets]: see (1974AJ01). $^9\text{B}^*(14.66)$ is the first $T = \frac{3}{2}$ state in ^9B . Its decay properties are displayed in Table 9.3 and compared with those of $^9\text{Be}^*(14.40)$: see reaction 9 in ^9Be and (1974AJ01). Angular distributions have been measured at $E(^3\text{He}) = 1.56$ to 5.27 MeV: see (1974AJ01).

$$5. \text{ (a) } ^7\text{Be}(d, n)^8\text{B} \quad Q_{\text{m}} = -2.087 \quad E_{\text{b}} = 16.489$$

$$\text{ (b) } ^7\text{Be}(d, p)^8\text{Be} \quad Q_{\text{m}} = 16.6740$$

The cross section for reaction (a) for $E(^7\text{Be}) = 16.9$ MeV is 58 ± 11 mb (1983HA17, 1985HA40). For $E_{\text{d}} = 0.75$ to 1.70 MeV, resonances in the yields of protons are observed at $E_{\text{d}} = 0.900 \pm 0.025$ MeV (p_0, p_1) and 1.475 ± 0.010 MeV (p_1 only) with $\Gamma_{\text{c.m.}} = 120 \pm 40$ and 71 ± 8 keV, respectively [$^9\text{B}^* = 17.19$ and 17.64 MeV]: see (1974AJ01). See also (1985CA41; astrophys.).

Table 9.9: Energy levels of ${}^9\text{B}$

| E_x (MeV \pm keV) ^a | $J^\pi; T$ | $\Gamma_{\text{c.m.}}$ (keV) | Decay | Reactions |
|------------------------------------|---|------------------------------|----------------------------------|--|
| g.s. | $\frac{3}{2}^-; \frac{1}{2}$ | 0.54 ± 0.21 | p, α | 1, 2, 3, 4, 6, 7, 8, 9, 10, 11, 12, 13, 14, 15, 16 |
| (1.6) ^b | | ≈ 700 | (p, α) | 4, 7, 12 |
| 2.361 ± 5 | $\frac{5}{2}^-; \frac{1}{2}$ | 81 ± 5 | α | 1, 2, 4, 6, 7, 8, 9, 10, 11, 12, 13, 14, 15, 16 |
| 2.788 ± 30 ^c | $(\frac{3}{2}, \frac{5}{2})^+; \frac{1}{2}$ | 550 ± 40 | p | 4, 6, 9, 10, 12, 14 |
| 4.8 ± 100 | | 1200 ± 200 | α | 4, 7, 12 |
| 6.97 ± 60 | $\frac{7}{2}^-; \frac{1}{2}$ | 2000 ± 200 | p | 4, 6, 10, 13, 14 |
| 11.70 ± 70 | $(\frac{7}{2})^-; \frac{1}{2}$ | 800 ± 50 | p | 10, 12 |
| 12.06 ± 60 | $;$ $\frac{1}{2}$ | 800 ± 200 | p | 4, 9, 13 |
| 14.01 ± 70 | $;$ $\frac{1}{2}$ | 390 ± 110 | | 4, 13 |
| 14.6550 ± 2.5 | $\frac{3}{2}^-; \frac{3}{2}$ | 0.395 ± 0.042 | γ , p | 4, 7, 13 |
| 14.7 ± 180 | $(\frac{5}{2})^-; \frac{1}{2}$ | 1350 ± 200 | | 10 |
| 15.29 ± 40 | $;$ $\frac{1}{2}$ | | | 13 |
| 15.58 ± 40 | $;$ $\frac{1}{2}$ | | | 13 |
| 16.024 ± 25 | $;$ $(\frac{1}{2})$ | 180 ± 16 | | 4, 13 |
| 17.076 ± 4 | $T = \frac{3}{2}$ | 22 ± 5 | $(\gamma, {}^3\text{He})$ | 1, 13 |
| 17.190 ± 25 | | 120 ± 40 | p, d, ${}^3\text{He}$ | 4, 5, 13 |
| 17.637 ± 10 | | 71 ± 8 | p, d, ${}^3\text{He}$, α | 1, 4, 5, 13 |
| (18.6) | | 1000 | p, ${}^3\text{He}$ | 1, 7, 10 |

^a See reactions 6 and 7 for additional states and other values.

^b See the discussion in (1987BA54; theor.). See also reaction 7.

^c See also reactions 6 and 9 for the possible existence of a $\frac{1}{2}^-$ state at $E_x \approx 2.8$ MeV [the analog to ${}^9\text{Be}^*(2.78)$], and see (1988MI03).

6. (a) ${}^9\text{Be}(p, n){}^9\text{B}$ $Q_m = -1.851$
 (b) ${}^9\text{Be}(p, pn){}^8\text{Be}$ $Q_m = -1.6654$

Angular distributions have been reported at many energies in the range $E_p = 3.5$ to 49.3 MeV [see (1979AJ01, 1984AJ01)] and at 16.44 and 17.57 MeV (1986MU07; n_0).

The width of the ground state is 0.54 ± 0.21 keV: see (1974AJ01). At $E_p = 135$ MeV, neutron groups are reported to states at $0, 2.36, 2.71 \pm 0.1$ [$\Gamma = 0.7 \pm 0.1$ MeV], 2.75 ± 0.3 [3.1 ± 0.2], 4.3 ± 0.2 [1.6 ± 0.2], 12.23 ± 0.1 [0.5 ± 0.1], 13.96 ± 0.1 [not broad] and 14.60 ± 0.1 [0.6 ± 0.1] MeV ((1985PU1A); Ph.D. thesis quoted and discussed in (1988MI03)) [Γ in MeV]. For the earlier work see (1979AJ01, 1984AJ01). Reaction (b) does not seem to involve states of ${}^9\text{B}$. See also (1984BA1R, 1988BO47, 1988HE08), (1984ALYS, 1987VO1F; applications), (1983BY02, 1987RA32) and (1982GU13; theor.). For yield and polarization measurements see ${}^{10}\text{B}$.

7. ${}^9\text{Be}({}^3\text{He}, t){}^9\text{B}$ $Q_m = -1.087$

Angular distributions have been measured for $E({}^3\text{He}) = 3.0$ to 25 MeV and at 217 MeV: see (1974AJ01, 1979AJ01). At $E({}^3\text{He}) = 39.8$ MeV, ${}^9\text{B}_{\text{g.s.}}$ is strongly populated and ${}^9\text{B}^*(2.4, 14.7)$ are also observed: see (1974AJ01). At $E({}^3\text{He}) = 90$ MeV triton groups are reported to states at $E_x = 1.16 \pm 0.05$ [1.3 ± 0.05], 4.8 ± 0.03 [1.5 ± 0.3], 16.7 ± 0.1 [< 0.1], 18.6 ± 0.3 and 20.7 ± 0.5 [1.6 ± 0.3] MeV [Γ in MeV], in addition to ${}^9\text{B}^*(2.36, 2.79, 7.0)$ and unresolved states at higher E_x (1987KA36). See also (1983DJZV).

8. (a) ${}^9\text{Be}({}^6\text{Li}, {}^6\text{He}){}^9\text{B}$ $Q_m = -4.575$
 (b) ${}^9\text{Be}({}^7\text{Li}, {}^7\text{Be}){}^9\text{B}$ $Q_m = -1.930$

At $E({}^6\text{Li}) = 32$ MeV angular distributions are reported to ${}^9\text{B}^*(0, 2.36)$ (1985CO09). A weak group between these two may have been populated (1987BUZZ; prelim.). See also (1984GL06; $E({}^6\text{Li}) = 93$ MeV, $E({}^7\text{Li}) = 78$ MeV).

9. ${}^9\text{C}(\beta^+){}^9\text{B}$ $Q_m = 16.498$

The β^+ decay is observed to ${}^9\text{B}^*(0, 2.36, 2.8)$ [$J^\pi = \frac{3}{2}^-, \frac{5}{2}^-, \frac{1}{2}^-$] with branching ratios of (60 ± 10) , (17 ± 6) and $(11 \pm 5)\%$. A state at $E_x = 12.1 \pm 0.6$ MeV, $\Gamma = 0.4 \pm 0.1$ MeV is also observed. The remaining strength goes to it (1988MI03; and D. Mikolas, priv. comm.). See also (1988MI1G). For an earlier study on delayed protons observed in the decay of ${}^9\text{C}$ see reaction 9 and Table 9.10 in (1974AJ01).

Table 9.10: Levels of ${}^9\text{B}$ from ${}^{10}\text{B}(\text{p}, \text{d}){}^9\text{B}$ ^a

| E_x (MeV \pm keV) | $\Gamma_{\text{c.m.}}$ (MeV) | l_n | J^π ^b |
|-------------------------------------|------------------------------|-------|----------------------|
| 0 | | 1 | $\frac{3}{2}^-$ |
| 2.35 ± 20 (2.9) ^c | | 1 | $\frac{5}{2}^-$ |
| 7.1 ± 140 | 2.15 ± 0.15 | 1 | $\frac{7}{2}^-$ |
| 11.70 ± 70 | 0.80 ± 0.05 | 1 | $(\frac{7}{2})^-$ |
| 14.7 ± 180 (18.4) | 1.35 ± 0.2 | 1 | $(\frac{5}{2})^-$ |

^a For references see Table 9.11 in (1974AJ01).

^b J from best fit to theoretical spectroscopic factor.

^c Weak group.

$$10. \text{ (a) } {}^{10}\text{B}(\text{p}, \text{d}){}^9\text{B} \quad Q_m = -6.212$$

$$\text{ (b) } {}^{10}\text{B}(\text{p}, \text{pn}){}^9\text{B} \quad Q_m = -8.436$$

Angular distributions are reported at $E_p = 18.6$ MeV involving ${}^9\text{B}^*(0, 2.36)$ (1985BE13). For other observed groups see Table 9.10. For reaction (b) see (1985BE30, 1985DO16; $E_p = 1$ GeV; prelim.). See also (1988GUZW).

$$11. {}^{10}\text{B}(\text{d}, \text{t}){}^9\text{B} \quad Q_m = -2.179$$

Angular distributions have been measured at $E_d = 11.8$ to 28 MeV [see (1974AJ01, 1979AJ01)] and 18 MeV (1988GO02; to ${}^9\text{B}^*(0, 2.36)$). See also (1983DJZV), (1988GUZW) and (1984SHZJ; theor.).

$$12. \text{ (a) } {}^{10}\text{B}({}^3\text{He}, \alpha){}^9\text{B} \quad Q_m = 12.141$$

$$\text{ (b) } {}^{10}\text{B}({}^3\text{He}, \alpha\text{p}){}^8\text{Be} \quad Q_m = 12.3267$$

$$\text{ (c) } {}^{10}\text{B}({}^3\text{He}, 2\alpha){}^5\text{Li} \quad Q_m = 10.45$$

Alpha-particle spectra show the excitation of ${}^9\text{B}^*(0, 2.4, 2.8, 11.8)$: see (1966LA04). $E_x = 2.361 \pm 0.005$ and 2.788 ± 0.030 MeV, $\Gamma = 81 \pm 5$ and 548 ± 40 keV, respectively. There is some evidence for a state with $E_x \approx 1.6$ MeV, $\Gamma \approx 0.7$ MeV, but it is not conclusive. No evidence

is found for any narrow levels in ${}^9\text{B}$ with $\Gamma \leq 100$ keV and $4 < E_x < 7$ MeV: the upper limit to the intensity of the corresponding α -group is 1% of the intensity of the group to ${}^9\text{B}^*(2.4)$. Angular distributions have been determined at $E({}^3\text{He}) = 5.5$ and 33.7 MeV [see (1974AJ01)] and at $E({}^3\text{He}) = 22.7$ MeV (1987VA11; to ${}^9\text{B}^*(0, 2.36)$; prelim.).

In reaction (b) study of the decays of ${}^9\text{B}^*(2.4, 2.8)$ shows that ${}^9\text{B}^*(2.4)$ decays $< 0.5\%$ by proton emission to ${}^8\text{Be}(0)$ [it decays to ${}^5\text{Li}(0)$ by α -emission] while the second state, $E_x = 2.71 \pm 0.03$ MeV [$\Gamma = 0.71 \pm 0.06$ MeV], decays almost 100% by that channel [$\theta^2 = 0.74$]. No other excited states of ${}^9\text{B}$ with $3.5 < E_x < 9.5$ MeV decay by proton emission to ${}^8\text{Be}(0)$: see (1974AJ01). In a kinematically complete experiment (reaction(c)) at $E({}^3\text{He}) = 2.3$ and 5.0 MeV, the E_x of ${}^9\text{B}^*(4.8)$ is estimated to be 4.9 ± 0.2 MeV, and its width to be 1.5 ± 0.3 MeV (1986AR14). A preliminary report of a study of reactions (b) and (c) at $E({}^3\text{He}) = 2.3$ and 5 MeV suggests $E_x = 1.8 \pm 0.3$ MeV, $\Gamma = 0.9 \pm 0.3$ MeV (1988AR05). See also (1983DJZV) and (1988GOZB; theor.).

13. ${}^{11}\text{B}(\text{p}, \text{t}){}^9\text{B}$ $Q_m = -11.409$

At $E_p = 45$ MeV angular distributions have been obtained for the triton groups to ${}^9\text{B}^*(0, 2.36, 12.06, 14.01, 14.66, 16.02)$. In addition the spectra show some indication of the groups corresponding to ${}^9\text{B}^*(7.0, 17.19, 17.64)$. $T = \frac{1}{2}$ states are reported at $E_x = 15.29 \pm 0.04$ and 15.58 ± 0.04 MeV. The first two $T = \frac{3}{2}$ states have been observed at $E_x = 14.6550 \pm 0.0025$ and 17.076 ± 0.004 MeV [$\Gamma = 22 \pm 5$ keV]: see (1974AJ01, 1979AJ01). See also (1987KW01; theor.).

14. (a) ${}^{12}\text{C}(\text{p}, \alpha){}^9\text{B}$ $Q_m = -7.552$
 (b) ${}^{12}\text{C}(\text{p}, \text{p})3\text{ }{}^4\text{He}$ $Q_m = -7.27473$
 (c) ${}^{12}\text{C}(\text{p}, \text{pt}){}^9\text{B}$ $Q_m = -27.366$

Angular distributions have been measured at $E_p = 14.0$ to 54.1 MeV [see (1974AJ01)] and at $E_p = 42.8$ MeV (1983PE07; to ${}^9\text{B}^*(0, 2.36, 6.98)$). The transitions to these three states involve $L = 1, 3$ and 3 , respectively (1983PE07). Earlier work is consistent with $J^\pi = \frac{7}{2}^-$, $\Gamma = 2$ MeV, $E_x = 6.97 \pm 0.06$ MeV. A state at 2.9 ± 0.2 MeV has also been reported: see (1974AJ01). Angular distributions involving the α_0 and α^* groups [to ${}^4\text{He}^*(20.1), 0^+$] to ${}^9\text{B}_{\text{g.s.}}$ have been studied at $E_p = 42$ MeV: see (1984AJ01). For reaction (c) see (1985DE17; $E_p = 58$ MeV). See also (1984AJ01) and (1985MAZG, 1986GO28, 1987GA08; theor.).

15. ${}^{12}\text{C}({}^3\text{He}, {}^6\text{Li}){}^9\text{B}$ $Q_m = -11.570$

Angular distributions have been studied at $E({}^3\text{He}) = 30.0$ and 40.7 MeV [see (1974AJ01)] and at $E({}^3\text{He}) = 33.4$ MeV (1986CL1B; to ${}^9\text{B}^*(0, 2.36)$; also A_y ; prelim.).

Table 9.11: Energy levels of ${}^9\text{C}$

| E_x (MeV \pm keV) | $J^\pi; T$ | $\tau_{1/2}$ or Γ | Decay | Reactions |
|------------------------|--------------------------------|--|-----------|---------------------------|
| g.s. 2.218 \pm 11 | $(\frac{3}{2}^-); \frac{3}{2}$ | $\tau_{1/2} = 126.5 \pm 0.9$ msec $\Gamma = 100 \pm 20$ keV | β^+ | 1, 2, 3 ^a 3 |

^a See also (1974AJ01, 1979AJ01).

16. ${}^{12}\text{C}(\alpha, {}^7\text{Li}){}^9\text{B}$ $Q_m = -24.898$

Angular distributions have been measured at $E_\alpha = 49.0$ and 80.1 MeV (1984GO03). See also (1984AJ01).

${}^9\text{C}$
(Figs. 3 and 4)

GENERAL: See also (1984AJ01).

Model calculations: (1983AU1B).

Complex reactions involving ${}^9\text{C}$: (1983FR1A, 1983OL1A, 1986HA1B, 1987SN01).

Reactions involving pions: (1983AS1B, 1984BR22, 1985PN01).

Other topics: (1982KA1D, 1985AN28, 1986AN07).

Ground state of ${}^9\text{C}$: (1983ANZQ, 1983AU1B, 1985AN28, 1987SA15).

1. ${}^9\text{C}(\beta^+){}^9\text{B}$ $Q_m = 16.498$

The half-life of ${}^9\text{C}$ is 126.5 ± 0.9 msec: see (1974AJ01). The decay is complex: see reaction 9 in ${}^9\text{B}$.

2. ${}^9\text{Be}(\pi^+, \pi^-){}^9\text{C}$ $Q_m = -17.566$

See (1984AJ01). See also (1986SE04).

3. $^{12}\text{C}(^3\text{He}, ^6\text{He})^9\text{C}$

$$Q_m = -31.575$$

At $E(^3\text{He}) = 74.1$ MeV a ^6He group is observed to the ground state and to a state at $E_x = 2218 \pm 11$ keV, $\Gamma = 100 \pm 20$ keV: see (1984AJ01).

^9N

(Not illustrated)

Not observed: see (1984AJ01) and (1983ANZQ, 1986AN40; theor.).

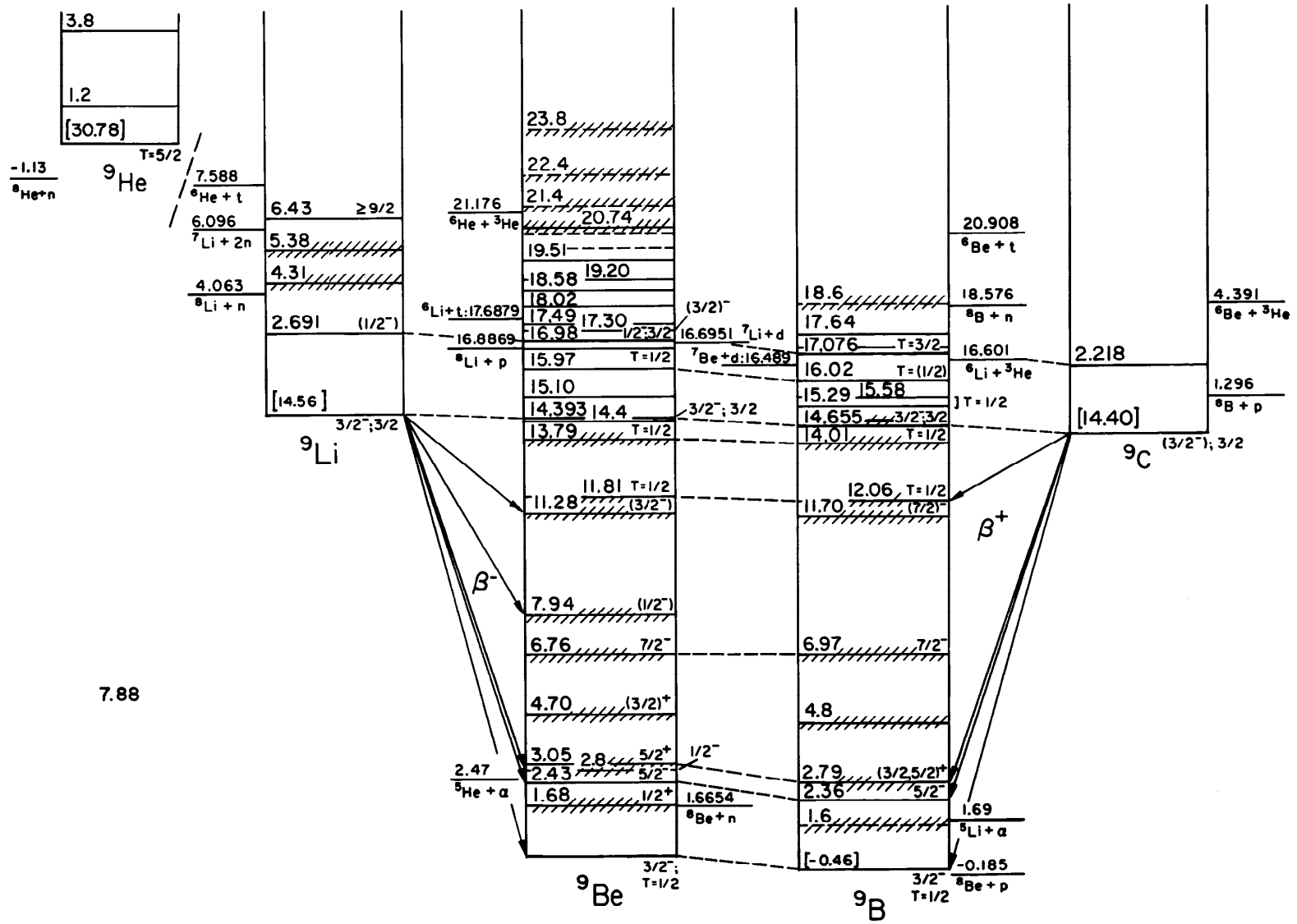

Fig. 4: Isobar diagram, $A = 9$. The diagrams for individual isobars have been shifted vertically to eliminate the neutron-proton mass difference and the Coulomb energy, taken as $E_C = 0.60Z(Z - 1)/A^{1/3}$. Energies in square brackets represent the (approximate) nuclear energy, $E_N = M(Z, A) - ZM(\text{H}) - NM(\text{n}) - E_C$, minus the corresponding quantity for ${}^9\text{Be}$: here M represents the atomic mass excess in MeV. Levels which are presumed to be isospin multiplets are connected by dashed lines.

References

(Closed 1 June 1988)

- 1966LA04 T. Lauritsen and F. Ajzenberg-Selove, Nucl. Phys. 78 (1966) 1
- 1974AJ01 F. Ajzenberg-Selove and T. Lauritsen, Nucl. Phys. A227 (1974) 1
- 1974KA15 E. Kashy, W. Benenson and J.A. Nolen, Jr., Phys. Rev. C9 (1974) 2102
- 1978LEZA C.M. Lederer, V.S. Shirley, E. Browne, J.M. Dairiki, R.E. Doebler, A.A. Shihab-Eldin, L.J. Jardine, J.K. Tuli and A.B. Buyrn, Table of Isotopes 7th Ed. (1978)
- 1979AJ01 F. Ajzenberg-Selove, Nucl. Phys. A320 (1979) 1
- 1980AJ01 F. Ajzenberg-Selove and C.L. Busch, Nucl. Phys. A336 (1980) 1
- 1981CO08 W.D. Cornelius, J.M. Moss and T. Yamaya, Phys. Rev. C23 (1981) 1364
- 1981PL1A G.R. Plattner, Nukleonika 26 (1981) 1005
- 1982AU1A Audouze and Reeves, Essays in Nucl. Astrophys. (1982) 355
- 1982BE1E Bertozzi et al., IUCF Sci. Tech. Rept. (1982)
- 1982CA1A Cameron, Essays in Nucl. Astrophys. (1982) 23
- 1982CI1A D.M. Ciric, B.Z. Stepanic and R.B. Zakula, Zb. Rad. Prir.-Mat. Fak. Ser. Fiz. 12 (1982) 51
- 1982DR08 A.V. Drobinin, M. Leonard and Yu.M. Tsipenyuk, At. Energ. 53 (1982) 398; Sov. At. Energy 53 (1982) 858
- 1982DZ1A R.I. Dzhibuti and Sh.M. Tsiklauri, Yad. Fiz. 36 (1982) 1387; Sov. J. Nucl. Phys. 36 (1982) 805
- 1982FU11 M. Fujishiro, T. Tabata, K. Okamoto and T. Tsujimoto, Can. J. Phys. 60 (1982) 1672
- 1982GU13 M. Gulyamov, G. Kim and S.M. Bekbaev, Yad. Fiz. 36 (1982) 572; Sov. J. Nucl. Phys. 36 (1982) 332
- 1982GU21 I.S. Gurbanovich and N.S. Zelenskaya, Yad. Fiz. 36 (1982) 1180; Sov. J. Nucl. Phys. 36 (1982) 688
- 1982KA1D K. Kar and J.C. Parikh, Pramana 19 (1982) 555
- 1982MO1B T. Motoba, Proc. Workshop on Hypernucl. Phys., Japan (1982) 36
- 1982PE03 R.J. Peterson, Nucl. Phys. A377 (1982) 41
- 1983AL04 G.D. Alkhazov and O.A. Domchenkov, Yad. Fiz. 37 (1983) 84; Sov. J. Nucl. Phys. 37 (1983) 46
- 1983AL10 M. Allab, A. Boucenna and M. Haddad, J. Phys. (Paris) 44 (1983) 579

- 1983AN18 M.N. Andronenko, E.N. Volnin, A.A. Vorobev, V.T. Grachev, A.A. Lobodenko, I.I. Straskovsky and L.N. Uvarov, *Pisma Zh. Eksp. Teor. Fiz.* 37 (1983) 446; *JETP Lett. (USSR)* 37 (1983) 530
- 1983ANZQ Y. Ando, M. Uno and M. Yamada, JAERI-M-83-025 (1983)
- 1983AR24 E.A. Arakelyan, G.L. Bayatyan, G.S. Vartanyan, N.K. Grigoryan, S.G. Knyazyan, A.O. Kechechyan, A.T. Margaryan, G.G. Marikyan, S.S. Stepanyan and S.R. Shakhazizyan, *Yad. Fiz.* 38 (1983) 1455; *Sov. J. Nucl. Phys.* 38 (1983) 589
- 1983AS1B Aslanides et al., in Florence (1983) 642
- 1983AU1A Auerbach et al., *Ann. Phys.* 148 (1983) 381
- 1983AU1B N. Auerbach, *Phys. Rept.* 98 (1983) 273
- 1983BA1D H. Bando, *Prog. Theor. Phys.* 69 (1983) 1731
- 1983BA1M Barnes et al., in Florence (1983) 389
- 1983BA52 F.C. Barker, *Can. J. Phys.* 61 (1983) 1371
- 1983BA71 C.J. Batty, *Nucl. Phys.* A411 (1983) 399
- 1983BE45 R. Bergere, *Nuovo Cim.* A76 (1983) 147
- 1983BE51 T.L. Belyaeva, N.S. Zelenskaya and I.B. Teplov, *Yad. Fiz.* 38 (1983) 901; *Sov. J. Nucl. Phys.* 38 (1983) 540
- 1983BE55 J.J. Bevelacqua, *Indian J. Phys.* A57 (1983) 26
- 1983BI13 J.R. Birkelund and J.R. Juizenga, *Ann. Rev. Nucl. Part. Sci.* 33 (1983) 265
- 1983BO1B O. Bohigas, *Prog. Theor. Phys. Suppl.* 74-75 (1983) 380
- 1983BR1E Bromley, in Florence (1983) 3
- 1983BU1D Burgov et al., *Sov. J. Nucl. Phys.* 38 (1983) 597
- 1983BY02 R.C. Byrd, P.W. Lisowski, W. Tornow and R.L. Walter, *Nucl. Phys.* A404 (1983) 29
- 1983CA22 M. Cavinato, M. Marangoni and A.M. Saruis, *Nuovo Cim.* A76 (1983) 197
- 1983CH23 B. Chambon, D. Drain, C. Pastor, A. Dauchy, A. Giorni and C. Morand, *Z. Phys.* A312 (1983) 125
- 1983CO11 F.D. Correll, L. Madansky, R.A. Hardekopf and J.W. Sunier, *Phys. Rev.* C28 (1983) 862
- 1983DA10 B. Dasmahapatra, B. Cujec and F. Lahlou, *Can. J. Phys.* 61 (1983) 657
- 1983DA22 J.H. Dave and C.R. Gould, *Phys. Rev.* C28 (1983) 2212
- 1983DE50 A.S. Deineko, I.I. Zalyubovsky, V.D. Sarana, A.I. Tutubalin, N.A. Shlyakhov and C. Hategan, *Izv. Akad. Nauk. SSSR Ser. Fiz.* 47 (1983) 2271
- 1983DJZV A. Djalojeis, J. Bojowald, G. Paic and B. Antolkovic, in Florence (1983) 235
- 1983DU13 G.G. Dussel, A.O. Gattone and E.E. Maqueda, *Phys. Rev. Lett.* 51 (1983) 2366

- 1983EF1A V.I. Efremenko, *Yad. Fiz.* 37 (1983) 118; *Sov. J. Nucl. Phys.* 37 (1983) 66
- 1983EN04 Y.M. Engel and R.D. Levine, *Phys. Rev. C*28 (1983) 2321
- 1983FE07 V.N. Fetisov, L. Majling, J. Zofka and R.A. Eramzhyan, *Z. Phys.* A314 (1983) 239
- 1983FI13 B.W. Filippone, A.J. Elwyn, C.N. Davids and D.D. Koetke, *Phys. Rev. C*28 (1983) 2222
- 1983FR1A W.A. Friedman and W.G. Lynch, *Phys. Rev. C*28 (1983) 950
- 1983FR1B Frois, in *Florence* (1983) 221
- 1983FU13 M. Fujishiro, K. Okamoto and T. Tsujimoto, *Can. J. Phys.* 61 (1983) 1579
- 1983GE12 P.M. Gensini, *Lett. Nuovo Cim.* 38 (1983) 469
- 1983GE13 P.M. Gensini, *Lett. Nuovo Cim.* 38 (1983) 620
- 1983GE1C P.M. Gensini, *Nuovo Cim* A78 (1983) 471
- 1983GM1A M. Gmitro, H.R. Kissener, P. Truol and R.A. Eramzhyan, *Fiz. Elem. Chastits At. Yadra* 14 (1983) 773; *Sov. J. Part. Nucl.* 14 (1983) 323
- 1983GO28 A.N. Goltsov and N.G. Goncharova, *Yad. Fiz.* 38 (1983) 1410; *Sov. J. Nucl. Phys.* 38 (1983) 857
- 1983GR18 K.A. Gridnev, E.F. Hefter, K. Mikulas, V.M. Semjonov and V.B. Subbotin, *Aust. J. Phys.* 36 (1983) 155
- 1983GR21 R.E.L. Green, D.H. Boal, R.L. Helmer, K.P. Jackson and R.G. Korteling, *Nucl. Phys.* A405 (1983) 463
- 1983GU10 M. Guidetti, P.F. Nali and P. Quarati, *Nuovo Cim.* A75 (1983) 191
- 1983GU1A C. Guet, *Nucl. Phys.* A400 (1983) 191
- 1983HA17 R.C. Haight, G.J. Mathews, R.M. White, L.A. Aviles and S.E. Woodard, *Nucl. Instrum. Meth.* 212 (1983) 245
- 1983HA1C Harvey et al., in *Florence* (1983) 511
- 1983HA45 S. Hayashi and S. Iwata, *Annu. Rep. Res. Reactor Inst., Kyoto Univ.* 16 (1983) 131
- 1983JA09 L. Jarczyk, B. Kamys, Z. Rudy, A. Strzalkowski, H. Witala, M. Hugi, J. Lang, R. Muller, J. Sromicki and H.H. Wolter, *Phys. Rev. C*28 (1983) 700
- 1983KA17 B. Kamys, L. Jarczyk, Z. Rudy, A. Strzalkowski, H.H. Wolter, J. Lang, R. Muller and J. Sromicki, *Nucl. Phys.* A406 (1983) 193
- 1983KA1A S.G. Kadenskii and Yu.L. Ratis, *Yad. Fiz.* 38 (1983) 1325; *Sov. J. Nucl. Phys.* 38 (1983) 805
- 1983KO1C N.N. Kolesnikov, V.A. Kopylov and A.V. Prudkoglyad, *Izv. Vyssh. Uchebn. Zaved. Fiz. (USSR)* 26 (1983) 101; *Sov. Phys. J.* 26 (1983) 768
- 1983KO1D Koutroulos, in *Florence* (1983) 689

- 1983KU06 V.I. Kukulín, V.N. Pomerantsev, V.G. Emelyanov and V.I. Klimov, *Yad. Fiz.* 37 (1983) 862; *Sov. J. Nucl. Phys.* 37 (1983) 514
- 1983KU17 N. Kumar, *Nucl. Phys.* A410 (1983) 50
- 1983KU1C Kutschera, *Radiocarbon* 25 (1983) 677
- 1983LE17 P.M. Lewis, O. Karban, J.M. Barnwell, J.D. Brown, P.V. Drumm, J.M. Nelson and S. Roman, *Nucl. Phys.* A404 (1983) 205
- 1983LO11 R.W. Lourie, W. Bertozzi, T.N. Buti, J.M. Finn, F.W. Hersman, C. Hyde, J. Kelly, M.A. Kovash, S. Kowalski, M.V. Hynes et al., *Phys. Rev.* C28 (1983) 489
- 1983MA53 J.F. Mateja, J. Garman and A.D. Frawley, *Phys. Rev.* C28 (1983) 1579
- 1983MA64 M. May, S. Bart, S. Chen, R.E. Chrien, D. Maurizio, P. Pile, Y. Xu, R. Hackenburg, E. Hungerford, H. Piekarz et al., *Phys. Rev. Lett.* 51 (1983) 2085
- 1983MI08 D.J. Millener, J.W. Olness, E.K. Warburton and S.S. Hanna, *Phys. Rev.* C28 (1983) 497
- 1983MI1E K. Miyahara, K. Ikeda and H. Bando, *Prog. Theor. Phys.* 69 (1983) 1717
- 1983MO1C T. Motoba, H. Bando and K. Ikeda, *Prog. Theor. Phys.* 70 (1983) 189
- 1983NA08 M.N. Namboodiri, R.K. Choudhury, J.B. Natowitz, K. Hagel, L. Adler, P.L. Gonthier, H. Simon, S. Kniffen, R. Patton, E. Tomasi et al., *Phys. Rev.* C28 (1983) 460
- 1983OH04 S. Ohkubo, *Phys. Rev.* C28 (1983) 2312
- 1983OL1A D.L. Olson, B.L. Berman, D.E. Greiner, H.H. Heckman, P.J. Lindstrom and H.J. Crawford, *Phys. Rev.* C28 (1983) 1602
- 1983OR1A Oryu, Kircher and Kamada, in *Florence* (1983) 690
- 1983PE07 F. Pellegrini, D. Trivisonno, S. Avon, R. Bianchin and R. Rui, *Phys. Rev.* C28 (1983) 42
- 1983PO1D Povh, in *Florence* (1983) 455
- 1983RO22 S. Roman, O. Karban, M. Barnwell, J.D. Brown, P.V. Drumm, P.M. Lewis and J.M. Nelson, *Phys. Rev.* C28 (1983) 2515
- 1983SA20 G.R. Satchler, C.B. Fulmer, R.L. Auble, J.B. Ball, F.E. Bertrand, K.A. Erb, E.E. Gross and D.C. Hensley, *Phys. Lett.* B128 (1983) 147
- 1983SH19 K. Shoda, M. Yamazaki, M. Torikoshi, O. Sasaki, H. Tsubota and B.N. Sung, *Nucl. Phys.* A403 (1983) 469
- 1983SH1E Y.-J. Shi and F. Zhuang, *Phys. Energ. Fortis Phys. Nucl.* 7 (1983) 605
- 1983SH38 Y.-J. Shi, *Phys. Rev.* C28 (1983) 2452
- 1983SI1B J.A. Simpson, *Ann. Rev. Nucl. Part. Sci.* 33 (1983) 323
- 1983SO08 L.G. Sobotka, M.L. Padgett, G.J. Wozniak, G. Guarino, A.J. Pacheco, L.G. Moretto, Y. Chan, R.G. Stokstad, I. Tserruya and S. Wald, *Phys. Rev. Lett.* 51 (1983) 2187

- 1983SR01 J. Sromicki, M. Hugi, J. Lang, R. Muller, E. Ungricht, L. Jarczyk, B. Kamys, A. Magiera, Z. Rudy, A. Strzalkowski et al., Nucl. Phys. A406 (1983) 390
- 1983ST1A H. Stocker, G. Buchwald, G. Graebner, P. Subramanian, J.A. Maruhn, W. Greiner, B.V. Jacak and G.D. Westfall, Nucl. Phys. A400 (1983) 63
- 1983SU08 J.-I. Suzumura, Prog. Theor. Phys. 69 (1983) 1669
- 1983SZZY J. Szabo, M. Varnagy, Z.T. Body and J. Csikai, Proc. Int. Conf. Nucl. Data for Sci. and Tech., Geel, Belgium, 1982; Ed., K.H. Bockhoff (1983) 956
- 1983TR04 V.A. Tryasuchev, Yad. Fiz. 37 (1983) 305; Sov. J. Nucl. Phys. 37 (1983) 181
- 1983VA23 J. van der Plicht, H.C. Britt, M.M. Fowler, Z. Fraenkel, A. Gavron, J.B. Wilhelm, F. Plasil, T.C. Awes and G.R. Young, Phys. Rev. C28 (1983) 2022
- 1983VA31 A.G.M. van Hees and P.W.M. Glaudemans, Z. Phys. A314 (1983) 323
- 1983WA1F Wang et al., in Florence (1983) 591
- 1983WI1A Wilczynski, in Florence (1983) 305
- 1983ZA1B Zakharov and Sergeev, Sov. J. Nucl. Phys. 38 (1983) 653
- 1983ZH09 P.H. Zhang, K.L. Wen, S.M. Li, X.M. Bao, Y.J. Shi and Z.X. Sun, Chin. J. Nucl. Phys. 5 (1983) 1
- 1983ZH1B Y.S. Zhang, Y.G. Li Yangguo, W.W. Wang and T.N. Ruan, Kexue Tongbao 28 (1983) 465
- 1984AI1A Aivazyan et al., in Panic (1984) N6
- 1984AJ01 F. Ajzenberg-Selove, Nucl. Phys. A413 (1984) 1
- 1984AL22 A.S. Alimov, V.I. Mokeev, E.S. Omarov and I.M. Piskarev, Yad. Fiz. 40 (1984) 301; Sov. J. Nucl. Phys. 40 (1984) 190
- 1984ALYS M. Allab, INDC (NDS)-153/L (1984)
- 1984AN16 Yu.P. Antufyev, A.S. Deineko, I.I. Zalyubovsky, V.D. Sarana, V.E. Storizhko, A.I. Tutubalin, C. Hategan and N.A. Schliakhov, Yad. Fiz. 40 (1984) 53; Sov. J. Nucl. Phys. 40 (1984) 35
- 1984AN1B Anagnostatos, in Panic (1984) I56
- 1984AR02 R.G. Arnold, P.E. Bosted, C.C. Chang, J. Gomez, A.T. Katramatou, G.G. Petratos, A.A. Rahbar, S.E. Rock, A.F. Sill, Z.M. Szalata et al., Phys. Rev. Lett. 52 (1984) 727
- 1984AS1D F. Asai, H. Bando and M. Sano, Phys. Lett. B145 (1984) 19
- 1984BA09 K. Baba, I. Endo, H. Fukuma, K. Inoue, T. Kawamoto, T. Ohsugi, Y. Sumi, T. Takeshita, S. Uehara, Y. Yano et al., Nucl. Phys. A415 (1984) 462
- 1984BA1N B. Bassalleck, AIP Conf. Proc. 123 (1984) 867
- 1984BA1R V.N. Baturin, A.V. Khanzadeev, V.P. Koptev, E.M. Maev, M.M. Makarov, V.V. Nelyubin, G.V. Shcherbakov and V.V. Sulimov, in Panic (1984) I11

- 1984BA49 F.C. Barker, *Aust. J. Phys.* 37 (1984) 267
- 1984BE1C Belozarov et al., in *Alma Ata* (1984) 379
- 1984BO1A A.R. Bodmer, Q.N. Usmani and J. Carlson, *Phys. Rev.* C29 (1984) 684
- 1984BO1H L.N. Bogdanova and V.E. Markushin, *Fiz. Elem. Chastits At. Yadra* 15 (1984) 808; *Sov. J. Part. Nucl.* 15 (1984) 361
- 1984BR22 T. Bressani, E. Chiavassa, S. Costa, G. Dellacasa, N. De Marco, M. Gallio, A. Musso, E. Aslanides, G. Bergdolt, P. Fassnacht et al., *Phys. Rev.* C30 (1984) 1745
- 1984BR25 B.A. Brown, C.R. Bronk and P.E. Hodgson, *J. Phys. (London)* G10 (1984) 1683
- 1984BY03 R.C. Byrd, C.E. Floyd, K. Murphy, P.P. Guss and R.L. Walter, *Nucl. Phys.* A427 (1984) 36
- 1984CA1D T.A. Cahill, Y. Matsuda, D. Shadoan, R.A. Eldred and B.H. Kusko, *Nucl. Instrum. Meth. Phys. Res.* B231 (1984) 263
- 1984CH1G H.Z. Chen, F. Zhuang, X.J. Shi and X.N. Jin, *Chin. J. Nucl. Phys.* 6 (1984) 303
- 1984CH1H R.E. Chrien, *AIP Conf. Proc.* 123 (1984) 841
- 1984CH20 I.-T. Cheon, S.J. Choi and M.T. Jeong, *Phys. Lett.* B144 (1984) 312
- 1984CH24 Y. Chang and M.R. Meder, *Phys. Rev.* C30 (1984) 1320
- 1984CL11 B.C. Clark, S. Hama, J.A. McNeil, R.L. Mercer, L. Ray, B.D. Serot, D.A. Sparrow and K. Stricker-Bauer, *Phys. Rev. Lett.* 53 (1984) 1423
- 1984DA11 S. Date, K. Saito, H. Sumiyoshi and H. Tezuka, *Phys. Rev. Lett.* 52 (1984) 2344
- 1984DA17 B. Dasmahapatra, B. Cujec and F. Lahlou, *Nucl. Phys.* A427 (1984) 186
- 1984DA1D Daskaloyannis, Koutroulos, Grypeos and Saloupis, in *Panic* (1984) M5
- 1984DE1F Descroix, Unpublished Thesis, Univ. Lyon, France (1984)
- 1984DO20 T.W. Donnelly and I. Sick, *Rev. Mod. Phys.* 56 (1984) 461
- 1984FR13 H. Friedrich, *Phys. Lett.* B146 (1984) 135
- 1984FR1A P. Frobrich, *Phys. Rept.* 116 (1984) 337
- 1984FU10 C.B. Fulmer, G.R. Satchler, K.A. Erb, D.C. Hensley, R.L. Auble, J.R. Ball, F.E. Bertrand and E.E. Gross, *Nucl. Phys.* A427 (1984) 545
- 1984GA07 R.B. Galloway and A.M. Ghazarian, *Phys. Rev.* C29 (1984) 2349
- 1984GE1A D.F. Geesaman, *AIP Conf. Proc.* 123 (1984) 150
- 1984GL06 Yu.A. Glukhov, A.S. Demyanova, A.A. Ogloblin, S.B. Sakuta and V.V. Sukharevsky, *Yad. Fiz.* 40 (1984) 62; *Sov. J. Nucl. Phys.* 40 (1984) 41
- 1984GO03 A. Gokmen, H. Breuer, A.C. Mignerey, B.G. Glagola, K. Kwiatkowski and V.E. Viola, Jr., *Phys. Rev.* C29 (1984) 1595
- 1984GR08 R.E.L. Green, R.G. Korteling and K.P. Jackson, *Phys. Rev.* C29 (1984) 1806

- 1984GR20 K. Grotowski, Z. Majka, R. Planeta, M. Szczodrak, Y. Chan, G. Guarino, L.G. Moretto, D.J. Morrissey, L.G. Sobotka, R.G. Stokstad, I. Tserruya et al., Phys. Rev. C30 (1984) 1214
- 1984GU09 S.K. Gupta and S. Kailas, Z. Phys. A317 (1984) 75
- 1984HA1K Y. Han and T.-Z. Ruan, Phys. Energ. Fortis Phys. Nucl. 8 (1984) 267
- 1984HA43 Q. Haider and B. Cujec, Nucl. Phys. A429 (1984) 116
- 1984HA48 R.C. Haight, S.M. Grimes, R.G. Johnson and H.H. Barschall, Nucl. Sci. Eng. 87 (1984) 41
- 1984HA53 Q. Haider and F.B. Malik, At. Data Nucl. Data Tables 31 (1984) 185
- 1984HE03 R.L. Helmer, R.E.L. Green, K.P. Jackson and R.G. Korteling, Phys. Rev. C29 (1984) 676
- 1984HI1A A.S. Hirsch, A. Bujak, J.E. Finn, L.J. Gutay, R.W. Minich, N.T. Porile, R.P. Scharenberg and B.C. Stringfellow, Phys. Rev. C29 (1984) 508
- 1984HO09 S. Homma, M. Kanazawa, M. Koike, Y. Murata, H. Okuno, F. Soga, N. Yoshikawa and A. Sasaki, Phys. Rev. Lett. 52 (1984) 2026
- 1984HO24 S. Homma, M. Kanazawa, M. Koike, Y. Murata, H. Okuno, F. Soga, M. Sudo, M. Torikoshi, N. Yoshikawa, A. Sasaki et al., Phys. Rev. Lett. 53 (1984) 2536
- 1984HU1D B.Y. Huang, Y.D. Wang, R.F. Yuan, S.M. Li, X.M. Bao and Z.X. Sun Zuxun, Chin. J. Nucl. Phys. 6 (1984) 156
- 1984IM1A M. Imamura, Y. Hashimoto, K. Yoshida, I. Yamane, H. Yamashita, T. Inoue, S. Tanaka, H. Nagai, M. Honda, K. Kobayashi et al., Nucl. Instrum. Meth. Phys. Res. B233 (1984) 211
- 1984IN03 M. Inoue and S.E. Koonin, Phys. Rev. C30 (1984) 175
- 1984IS02 A.Z.M. Ismail, M.S. El-Nagdy, K.L. Gomber, M.M. Aggarwal and P.L. Jai, Phys. Rev. Lett. 52 (1984) 1280
- 1984JI05 R.I. Jibuti and Sh.M. Tsiklauri, Yad. Fiz. 40 (1984) 1171; Sov. J. Nucl. Phys. 40 (1984) 746
- 1984KO1B N.N. Kolesnikov, V.A. Kopylov and A.V. Kolesov, Moscow Univ. Phys. Bull. 39 (1984) 6
- 1984KO1E Komarov, Muller and Tesch, in Panic (1984) 120
- 1984KO33 J.H. Koch, E.J. Moniz and N. Ohtsuka, Ann. Phys. 154 (1984) 99
- 1984KO40 V.Ya. Kostin and V.Ya. Migaleny, Izv. Akad. Nauk SSSR Ser. Fiz. 48 (1984) 1021; Bull. Acad. Sci. USSR Phys. Ser. 48 (1984) 184
- 1984KR1B A.V. Kravtsov, N.P. Popov and G.E. Solvakin, JETP Lett. 40 (1984) 875
- 1984LE11 M. Lebrun, J. Deutsch, D. Favart, P. Lipnik, P. Macq and R. Prieels, Phys. Rev. C30 (1984) 383

- 1984LI07 V.P. Likhachev, I.G. Evseev, A.Yu. Buki, A.A. Nemashkalo, S.A. Pashchuk, G.A. Savitsky, V.M. Khvastunov, A.V. Fartushny, V.A. Stepanenko and V.B. Shostak, Ukr. Fiz. Zh. 29 (1984) 331
- 1984LI1E F. Liu, J.-R. Li and L.-S. Liu, Chin. Phys. Lett. 1 (1984) 43
- 1984LI28 Y.-G. Li and S.-Y. Lo, Aust. J. Phys. 37 (1984) 255
- 1984LIZY P.W. Lisowski, R.E. Brown, J.C. Gursky, S.D. Howe, N. Jarmie and G.L. Morgan, Bull. Amer. Phys. Soc. 29 (1984) 748, JH13
- 1984MA28 J.F. Mateja, J. Garman, D.E. Fields, R.L. Kozub, A.D. Frawley and L.C. Dennis, Phys. Rev. C30 (1984) 134
- 1984ME11 C.R. Meitzler, A.E. Khalil, A.B. Robbins and G.M. Temmer, Phys. Rev. C30 (1984) 1105
- 1984MI1C Millener, Gal, Dover and Dalitz, in Panic (1984) M7
- 1984MI1E D.J. Millener, AIP Conf. Proc. 123 (1984) 850
- 1984MIZM I.A. Mitropolsky and E.F. Hefter, in Alma Ata (1984) 241
- 1984MO09 T. Motoba, H. Bando and K. Ikeda, Prog. Theor. Phys. 71 (1984) 222
- 1984MO1D J.A. Montgomery, K.-B. Yoo, H. Uberall and B. Bosco, Can. J. Phys. 62 (1984) 764
- 1984MO1H T. Motoba, H. Bando and K. Ikeda, Proc. Int. Summer School, Changchun, China, 1983 (1984) 702
- 1984OC01 J.S. O'Connell, W.R. Dodge, J.W. Lightbody, Jr., X.K. Maruyama, J.-O. Adler, K. Hansen, B. Schroder, A.M. Bernstein, K.I. Blomqvist, B.H. Cottman et al., Phys. Rev. Lett. 53 (1984) 1627
- 1984OM02 A.R. Omar, J.S. Eck, J.R. Leigh and T.R. Ophel, Phys. Rev. C30 (1984) 896
- 1984OM03 A.R. Omar, J.S. Eck, T.R. Ophel and J.R. Leigh, Phys. Rev. C30 (1984) 1516
- 1984PO11 D.N. Poenaru and M. Ivascu, J. Phys. 45 (1984) 1099
- 1984RE14 S.M. Read and V.E. Viola, Jr., At. Data Nucl. Data Tables 31 (1984) 359
- 1984RO1B Romanov and Grechukhin, in Alma Ata (1984) 280, 281
- 1984SC1A E.W. Schmid, Nucl. Phys. A416 (1984) 347
- 1984SH01 G.R. Shen, S.L. Wen, T.Z. Huang, A.L. Li and X.X. Bai, Nucl. Sci. Eng. 86 (1984) 184
- 1984SH1K Sherif, in Panic (1984) I35
- 1984SHZJ A.A. Shvedov, V.N. Dobrikov and O.F. Nemets, in Alma-Ata (1984) 332
- 1984SI15 S.H. Simon, P.L. Gonthier, R.K. Choudhury, M.N. Namboodiri, K. Hagel, S. Kniffen, R. Patton, L. Adler and J.B. Natowitz, Nucl. Phys. A430 (1984) 249
- 1984TR1C J.W. Truran, Ann. Rev. Nucl. Part. Sci. 34 (1984) 53

- 1984VA06 A.G.M. van Hees and P.W.M. Glaudemans, *Z. Phys.* A315 (1984) 223
- 1984WA21 J.W. Watson, P.J. Pella, M. Ahmad, B.S. Flanders, N.S. Chant, P.G. Roos, D.W. Devins and D.L. Friesel, *J. Phys. Colloq.* 45 (1984) 91
- 1984WI06 N. Willis, L. Bimbot, T. Hennino, J.C. Jourdain, Y. Le Bornec and F. Reide, *Phys. Lett.* B136 (1984) 334
- 1984WO09 C.L. Woods and F.C. Barker, *Nucl. Phys.* A427 (1984) 73
- 1984XI1B Y.-X. Xie, Y.-T. Zhu, E.-P. Fen, X. Yin, H.-B. Miao, J.-X. Cai, F.-W. Li, W.-Q. Shen, S.-M. Sun, J.-J. Wei et al., *Phys. Energ. Fortis Phys. Nucl.* 8 (1984) 748
- 1984ZH1B F. Zhuang, H.-Z. Chen and X.-N. Jin, *Phys. Energ. Fortis Phys. Nucl.* 8 (1984) 215
- 1984ZW1A Zwarts, Unpublished Ph.D. Thesis, Utrecht Univ. (1984)
- 1985AG1A M.M. Aggarwal and P.L. Jain, *Phys. Rev.* C31 (1985) 1233
- 1985AH06 J. Ahrens, *Nucl. Phys.* A446 (1985) 229c
- 1985AH1A I. Ahmad, M. Mian and M.Z. Rahman Khan, *Phys. Rev.* C31 (1985) 1590
- 1985AL16 G.D. Alkhazov, S.L. Belostotsky, A.A. Vorobyov, O.A. Domchenkov, Yu.V. Dot-senko, N.P. Kuropatkin and V.N. Nikulin, *Yad. Fiz.* 42 (1985) 8; *Sov. J. Nucl. Phys.* 42 (1985) 4
- 1985AL1G Aleksandrov et al., *Questions in At. Phys. and in Tech.*, USSR (1985) 3
- 1985AN16 M.V. Andres, J.M. Quesada, M. Lozano and G. Madurga, *Nucl. Phys.* A443 (1985) 380
- 1985AN28 M.S. Antony, J. Britz, J.B. Bueb and A. Pape, *At. Data Nucl. Data Tables* 33 (1985) 447
- 1985AR15 E.A. Arakelyan, G.L. Bayatyan, G.S. Vartanyan, A.R. Voskanyan, N.K. Grigoryan, S.G. Knyazyan, A.T. Margaryan, G.G. Marikyan, E.M. Oganesyanyan, S.S. Stepanyan et al., *Yad. Fiz.* 42 (1985) 3; *Sov. J. Nucl. Phys.* 42 (1985) 1
- 1985AR1B H. Araseki and T. Fujita, *Nucl. Phys.* A439 (1985) 681
- 1985BA1V Yu.D. Bayukov, V.B. Gavrilov, N.A. Goryainov, Yu.G. Grishuk, O.B. Gushchin, P.V. Degtyarenko, G.A. Leksin, V.B. Fedorov, B.B. Shvartsman, S.V. Shevchenko et al., *Yad. Fiz.* 42 (1985) 377; *Sov. J. Nucl. Phys.* 42 (1985) 238
- 1985BE13 R.B. Begzhanov, E.A. Romanovsky, Yu.I. Denisov, A.M. Mukhamedzhanov, I.R. Gulamov, T. Iskhakov, G.K. Ni, R. Yarmukhamedov, G.S. Valiev and V.A. Stepanenko, *Izv. Akad. Nauk SSSR Ser. Fiz.* 49 (1985) 111; *Bull. Acad. Sci. USSR Phys. Ser.* 49 (1985) 117
- 1985BE1A M. Beckerman, *Phys. Rept.* 129 (1985) 145
- 1985BE1K A.M. Bernstein, *AIP Conf. Proc.* 133 (1985) 271

- 1985BE30 S.L. Belostotsky, S.S. Volkov, A.A. Vorobyev, Yu.V. Dotsenko, L.G. Kudin, N.P. Kuropatkin, O.V. Miklukho, V.N. Nikulin and O.E. Prokofyev, *Yad. Fiz.* 41 (1985) 1425; *Sov. J. Nucl. Phys.* 41 (1985) 903
- 1985BE59 C. Besliu, V. Popa, L. Popa and V. Topor-Pop, *Rev. Roum. Phys.* 30 (1985) 659
- 1985BH02 R. Bhanja, M. Shyam and S.K. Tuli, *Nucl. Phys.* A438 (1985) 740
- 1985BL18 J. Blocki, K. Grotowski, R. Planeta and W.J. Swiatecki, *Nucl. Phys.* A445 (1985) 367
- 1985BO1A Boal, *Adv. Nucl. Phys.* 15 (1985) 85
- 1985CA41 G.R. Caughlan, W. A. Fowler, M.J. Harris and B.A. Zimmerman, *At. Data Nucl. Data Tables* 32 (1985) 197
- 1985CL1A F.E. Close, *Nucl. Phys.* A446 (1985) 273
- 1985CO09 J. Cook and K.W. Kemper, *Phys. Rev.* C31 (1985) 1745
- 1985CU1A B. Cujec, *Lecture Notes in Phys.* 219 (1985) 108
- 1985DE17 E. Descroix, M. Bedjidian, J.Y. Grossiord, A. Guichard, M. Gusakow, M. Jacquin, J.R. Pizzi and G. Bagieu, *Nucl. Phys.* A438 (1985) 112
- 1985DE22 A. De Rosa, G. Inghima, M. Sandoli, G. Vourvopoulos and X. Aslanoglou, *Nuovo Cim.* A85 (1985) 269
- 1985DI1B F.S. Dietrich and F. Petrovich, *AIP Conf. Proc.* 124 (1985) 90
- 1985DO16 Yu.V. Dotsenko and V.E. Starodubsky, *Yad. Fiz.* 42 (1985) 107; *Sov. J. Nucl. Phys.* 42 (1985) 66
- 1985EL1A D. Elmore, P.W. Kubik, T. Hemmick, R. Teng, H. Kagan, P. Haas, R.N. Boyd, R. Turner, D. Nitz, D. Ciampa et al., *Nucl. Instrum. Meth. Phys. Res.* B10-11 (1985) 738
- 1985FA02 H. Faissner, B.R. Kim and H. Reithler, *Phys. Rev. Lett.* 54 (1985) 1902
- 1985FR13 K.A. Frankel, J.A. Bistirlich, R. Bossingham, H.R. Bowman, K.M. Crowe, C.J. Martoff, D.L. Murphy, J.O. Rasmussen, J.P. Sullivan, E. Yoo et al., *Phys. Rev.* C32 (1985) 975
- 1985GA1A Galanina and Zelenskaya, *Yad. Fiz.* 41 (1985) 86; *Sov. J. Nucl. Phys.* 41 (1985) 53
- 1985GLZZ C.W. Glover, E.E. Gross, A.W. Carpenter, J.A. Carr, R.J. Philpott, F. Petrovich, P. Schwandt, W.W. Jacobs and H.O. Meyer, *Bull. Amer. Phys. Soc.* 30 (1985) 701, AE9
- 1985GO1A N.G. Goncharova, H.-R. Kissener and R.A. Eramzhyan, *Fiz. Elem. Chastits At. Yadra* 16 (1985) 773; *Sov. J. Part. Nucl.* 16 (1985) 337
- 1985GO1H Gorionov et al., in *Leningrad* (1985) 362
- 1985GU1D Gulyamov et al., in *Leningrad* (1985) 292
- 1985GUZQ M.G. Gulyamov, M.A. Kayumov, K. Khamidova, F. Kadirov and M.Yu. Tashmetov, in *Leningrad* (1985) 321

- 1985HA02 L.F. Hansen, F.S. Dietrich, B.A. Pohl, C.H. Poppe and C. Wong, Phys. Rev. C31 (1985) 111
- 1985HA1H E. Hayward, AIP Conf. Proc. 125 (1985) 131
- 1985HA1J H.J. Hauser, T. Rohwer, F. Hoyler, G. Staudt, S. Abd el-Kariem, P. Grasshoff, H.V. Klapdor, A. Korber, W. Leitner, V. Rapp et al., AIP Conf. Proc. 125 (1985) 701
- 1985HA1K J.H. Hamilton, P.G. Hansen and E.F. Zganjar, Rept. Prog. Phys. 48 (1985) 631
- 1985HA1P W.S. Han, Z.Q. Lu and Z.X. Li, Chin. J. Nucl. Phys. 7 (1985) 220
- 1985HA40 R.C. Haight, G.J. Mathews and R.W. Bauer, Nucl. Instrum. Meth. Phys. Res. B10-11 (1985) 361
- 1985HO27 S. Homma, Nucl. Phys. A446 (1985) 241c
- 1985HU1B B.Y. Huang, Y.D. Wang, R.F. Yuan, J. Yuan, S.M. Li, X.M. Bao and Z.X. Sun, Chin. Phys. 5 (1985) 420
- 1985HY1A Hyde-Wright, Ph.D. Thesis (1985)
- 1985IK1A K. Ikeda, H. Bando and T. Motoba, Prog. Theor. Phys. Suppl. 81 (1985) 147
- 1985IM1A N. Imanishi, T. Furuya, I. Fujiwara, A. Shinohara, H. Kaji and S. Iwata, Phys. Rev. A32 (1985) 2584
- 1985JA09 L. Jarczyk, B. Kamys, A. Magiera, A. Strzalkowski, A. Szczurek, K. Bodek, M. Hugi, J. Lang, R. Muller and E. Ungricht, J. Phys. (London) G11 (1985) 843
- 1985JA18 B.V. Jacak, D. Fox and G.D. Westfall, Phys. Rev. C31 (1985) 704
- 1985KA01 M. Kawai and Y. Iseri, Phys. Rev. C31 (1985) 400
- 1985KA1J K. Katori, T. Shimoda, T. Fukuda, S. Shimoura and H. Ogata, J. Phys. Soc. Jpn. 54 (1985) 100
- 1985KI1A Kitching, McDonald, Maris and Vasconcellos, Adv. Nucl. Phys. 15 (1985) 43
- 1985KW02 E. Kwasniewicz and L. Jarczyk, Nucl. Phys. A441 (1985) 77
- 1985LA20 I.A. Lantsev, V.I. Ostroumov, Yu.R. Gismatulin, V.N. Zbarag and A.A. Melentev, Izv. Akad. Nauk SSSR Ser. Fiz. 49 (1985) 143; Bull. Acad. Sci. USSR Phys. Ser. 49 (1985) 149
- 1985LI15 V.P. Likhachev, I.G. Evseyev, A.A. Zayats, S.A. Pashchuk, G.A. Savitsky, V.A. Fartushny, O.G. Savchuk and V.B. Shostak, Ukr. Fiz. Zh. 30 (1985) 682
- 1985MA02 H. Machner, D. Protic, G. Riepe, H.G. Bohlen and H. Fuchs, Phys. Rev. C31 (1985) 443
- 1985MA13 M.T. Magda, A. Pop and A. Sandulescu, J. Phys. (London) G11 (1985) L75
- 1985MA1G J.L. Matthews, AIP Conf. Proc. 133 (1985) 296
- 1985MAZG B.S. Mazitov and E.N. Rasulov, in Leningrad (1985) 298

- 1985MC03 M.A. McMahan, L.G. Moretto, M.L. Padgett, G.J. Wozniak, L.G. Sobotka and M.G. Mustafa, Phys. Rev. Lett. 54 (1985) 1995
- 1985MI1E G. Michaud, AIP Conf. Proc. 126 (1985) 75
- 1985MO08 M. Morjean, J.L. Charvet, J.L. Uzureau, Y. Patin, A. Peghaire, Y. Pranal, L. Sinopoli, A. Billerey, A. Chevarier, N. Chevarier et al., Nucl. Phys. A438 (1985) 547
- 1985MO17 D.J. Morrissey, W. Benenson, E. Kashy, C. Bloch, M. Lowe, R.A. Blue, R.M. Ronningen, B. Sherrill, H. Utsunomiya and I. Kelson, Phys. Rev. C32 (1985) 877
- 1985MO1F T. Motoba, H. Bando, K. Ikeda and T. Yamada, Prog. Theor. Phys. Suppl. 81 (1985) 42
- 1985MO24 D.J. Morrissey, W. Benenson, E. Kashy, C. Bloch, M. Lowe, B. Sherrill, R.A. Blue, R.M. Ronningen and H. Utsunomiya, Nucl. Phys. A447 (1986) 603c
- 1985OS06 A. Osman and S.A. Saleh, Acta Phys. Pol. B16 (1985) 865
- 1985PAZL M.V. Pasechnik, L.S. Saltykov, E.P. Kadkin, I.I. Loshchakov and A.I. Vdovin, in Leningrad (1985) 296
- 1985PN01 J. Pniewski, K. Garbowska-Pniewska, D. Kielczewska, D.H. Davis, G. Bohm, U. Krecker, A. Montwill, P. Moriarty, G. Coremans-Bertrand, J. Sacton et al., Nucl. Phys. A443 (1985) 685
- 1985PO10 N.A.F.M. Poppelier, L.D. Wood and P.W.M. Glaudemans, Phys. Lett. B157 (1985) 120
- 1985PO11 D.N. Poenaru, M. Ivascu, A. Sandulescu and W. Greiner, Phys. Rev. C32 (1985) 572
- 1985PO18 J. Pochodzalla, W.A. Friedman, C.K. Gelbke, W.G. Lynch, M. Maier, D. Ardouin, H. Delagrange, H. Doubre, C. Gregoire, A. Kyanowski et al., Phys. Lett. B161 (1985) 256
- 1985PO19 J. Pochodzalla, W.A. Friedman, C.K. Gelbke, W.G. Lynch, M. Maier, D. Ardouin, H. Delagrange, H. Doubre, C. Gregoire, A. Kyanowski et al., Phys. Lett. B161 (1985) 275
- 1985PU1A B. Pugh, Ph.D. Thesis, MIT (1985)
- 1985RO10 G. Roepke, H. Schulz, L.N. Andronenko, A.A. Kotov, W. Neubert and E.N. Volnin, Phys. Rev. C31 (1985) 1556
- 1985RO15 G. Roy, H.S. Sherif, E.D. Cooper, L.G. Greeniaus, G.A. Moss, J. Soukup, G.M. Stinson, R. Abegg, D.P. Gurd, D.A. Hutcheon et al., Nucl. Phys. A442 (1985) 686
- 1985SA32 H. Sato and Y. Okuhara, Phys. Lett. B162 (1985) 217
- 1985SE15 R.E. Segel, S.M. Levenson, P. Zupranski, A.A. Hassan, S. Mukhopadhyay and J.V. Maher, Phys. Rev. C32 (1985) 721
- 1985SE1B K.K. Seth, Nucl. Phys. A434 (1985) 287
- 1985SH1G W.-Q. Shen, W.-M. Qiao, Y.-T. Zhu and W.-L. Zhan, Chin. Phys. 5 (1985) 657

- 1985SH24 R. Sherr and G. Bertsch, *Phys. Rev. C*32 (1985) 1809
- 1985SR01 B.B. Srivastava and A. Saxena, *Phys. Rev. C*31 (1985) 745
- 1985TA18 I. Tanihata, H. Hamagaki, O. Hashimoto, Y. Shida, N. Yoshikawa, K. Sugimoto, O. Yamakawa, T. Kobayashi and N. Takahashi, *Phys. Rev. Lett.* 55 (1985) 2676
- 1985TE01 J.A. Templon, J.H. Dave, C.R. Gould and S. Singkarat, *Nucl. Sci. Eng.* 91 (1985) 451
- 1985TR1B Trockel et al., in *Visby* (1985) 148
- 1985VD03 A.I. Vdovin, A.V. Golovin and I.I. Loshchakov, *Yad. Fiz.* 42 (1985) 134; *Sov. J. Nucl. Phys.* 42 (1985) 84
- 1985WA13 C.W. Wang, P.G. Roos, N.S. Chant, G. Ciangaru, F. Khazaie, D.J. Mack, A. Nadasen, S.J. Mills, R.E. Warner, E. Norbeck et al., *Phys. Rev. C*31 (1985) 1662
- 1985WA1F Waddington and Freier, in *Visby* (1985) 22
- 1985WA1K T.P. Walker, G.J. Mathews and V.E. Viola, *Astrophys. J.* 299 (1985) 745
- 1985WA22 S. Wald, S.B. Gazes, C.R. Albiston, Y. Chan, B.G. Harvey, M.J. Murphy, I. Tserruya, R.G. Stokstad, P.J. Countryman, K. Van Bibber et al., *Phys. Rev. C*32 (1985) 894
- 1985WE1A Wefel, Guzik, Garcia-Munoz and Simpson, *Bull. Amer. Phys. Soc.* 30 (1985) 764
- 1985WI18 J.S. Winfield, N.A. Jelley, W.D.M. Rae and C.L. Woods, *Nucl. Phys.* A437 (1985) 65
- 1985YA05 T. Yamada, K. Ikeda, H. Bando and T. Motoba, *Prog. Theor. Phys.* 73 (1985) 397
- 1985YU1A Z.-S. Yuan, Z.-Q. Cheng, Y.-D. Sun and Z.-H. Qiu, *Phys. Energ. Fortis Phys. Nucl.* 9 (1985) 765
- 1986AB04 S.N. Abramovich, B.Ya. Guzhovsky, A.G. Zvenigorodsky, S.V. Trusillo and S.A. Dunaeva, *Izv. Akad. Nauk SSSR Ser. Fiz.* 50 (1986) 65; *Bull. Acad. Sci. USSR Phys. Ser.* 50 (1986) 62
- 1986AB07 N.K. Abrosimov, V.A. Volchenkov, A.B. Gridnev, V.A. Eliseev, E.M. Ivanov, V.P. Koptev, S.P. Kruglov, Yu.A. Malov, S.M. Mikirtychyants, G.A. Ryabov et al., *Pisma Zh. Eksp. Teor. Fiz.* 43 (1986) 214; *JETP Lett.* 43 (1986) 270
- 1986AC1A W. Achenbach, J. Ahrens, H.G. Andresen, A. Bornheimer, D. Conrath, K.-J. Dietz, W. Gasteyer, H.-J. Gessinger, W. Hartmann, W. Heil et al., *Proc. Int. Symp. on Weak and Electromag. Interactions in Nuclei, Heidelberg, West Germany* (1986) 642
- 1986AN07 M.S. Antony, J. Britz and A. Pape, *At. Data Nucl. Data Tables* 34 (1986) 279
- 1986AN40 M. Anikina, A. Golokhvastov, K. Iovchev, S. Khorozov, E. Kuznetsova, J. Lukstins, E. Okonov, T. Ostonevich, V. Toneev, G. Vardenga et al., *Phys. Rev. C*33 (1986) 895
- 1986AR06 J. Arends, P. Detemple, N. Floss, A. Hegerath, S. Huthmacher, B. Mecking, G. Nold-
eke, R. Stenz and V. Werler, *Nucl. Phys.* A454 (1986) 579
- 1986AR14 N. Arena, Seb. Cavallaro, G. Fazio, G. Giardina, A. Italiano and F. Mezzanares, *Phys. Rev. Lett.* 57 (1986) 1839

- 1986AV1B Avdeichikov, in Dubna (1986) 122
- 1986AZ01 I.G. Aznauryan and I.A. Troshenkova, *Yad. Fiz.* 43 (1986) 342; *Sov. J. Nucl. Phys.* 43 (1986) 219
- 1986BA07 K. Baba, I. Endo, H. Fukuma, K. Inoue, S. Kouno, T. Kawamoto, T. Ohsugi, Y. Sumi, T. Takeshita, S. Uehara, Y. Yano and T. Maki, *Nucl. Phys.* A448 (1986) 578
- 1986BA1Q Yu.D. Bayukov, A.V. Vlasov, L.S. Vorob'ev, V.B. Gavrillov, N.A. Goryainov, Yu.G. Grishuk, P.V. Degtyarenko, Yu.V. Efremenko, L.N. Kuleshova, G.A. Leksin et al., *Yad. Fiz.* 44 (1986) 412; *Sov. J. Nucl. Phys.* 44 (1986) 263
- 1986BA1W H. Bando, *Nucl. Phys.* A450 (1986) 217c
- 1986BA2D R. Babinet, *Ann. Phys. (France)* 11 (1986) 113
- 1986BA2H Batii et al., in Kharkov (1986) 388
- 1986BA38 F.C. Barker and R.H. Spear, *Astrophys. J.* 307 (1986) 847
- 1986BA69 D. Baye, *Nucl. Phys.* A460 (1986) 581
- 1986BA85 D.S. Bagdasaryan, E.M. Boyakhchyan, G.B. Kazaryan, M.D. Karibyan, E.R. Markaryan, G.G. Mkrtchyan and I.A. Troshenkova, *Izv. Akad. Nauk Arm. SSR Fiz.* 21 (1986) 284; *Sov. J. Contemp. Phys.* 21 (1986) 58
- 1986BE1L Bekbaev, Kim, Mazitov and Eramzhian, in Kharkov (1986) 436
- 1986BE33 B. Bellenberg, H. Hemmert and E. Kuhlmann, *Phys. Rev.* C34 (1986) 1991
- 1986BI01 B.L. Birbrair, A.B. Gridnev, M.B. Zhalov, E.M. Levin and V.E. Starodubski, *Phys. Lett.* B166 (1986) 119
- 1986BO1E A.R. Bodmer and Q.N. Usmani, *Nucl. Phys.* A450 (1986) 257c
- 1986BO1H A.M. Boesgaard and R.J. Lavery, *Astrophys. J.* 309 (1986) 762
- 1986BU22 N.A. Burkova, M.A. Zhusupov and A.A. Chumbalov, *Izv. Akad. Nauk SSSR Ser. Fiz.* 50 (1986) 941; *Bull. Acad. Sci. USSR Phys. Ser.* 50 (1986) 109
- 1986CE04 C. Cernigoi, N. Grion, G. Pauli, R. Rui and R. Cherubini, *Nucl. Phys.* A456 (1986) 599
- 1986CH1J N.S. Chant, *AIP Conf. Proc.* 142 (1986) 246
- 1986CH1P R.E. Chrien, *Czech. J. Phys.* B36 (1986) 410
- 1986CL1B N.M. Clarke, P.J. Simmons, K.I. Pearce, S. Roman, A. Farooq and G. Rai, *J. Phys. Soc. Jpn. Suppl.* 55 (1986) 756
- 1986CR1B E. Cravo and A.C. Fonseca, *Few-Body Syst. Suppl.* 1 (1986) 221
- 1986CS1A L.P. Csernai and J.I. Kapusta, *Phys. Rept.* 131 (1986) 223
- 1986CU01 M.S. Curtin, L.H. Harwood, J.A. Nolen, B. Sherrill, Z.Q. Xie and B.A. Brown, *Phys. Rev. Lett.* 56 (1986) 34

- 1986CU02 B. Cujec, B. Dasmahapatra, Q. Haider, F. Lahlou and R.A. Dayras, Nucl. Phys. A453 (1986) 505
- 1986DA1B D.H. Davis and J. Pniewski, Contemp. Phys. 27 (1986) 91
- 1986DIZT R. Dierckx, W. Kley, A. Verga, E.V. Benton and J. Buschmann, Radiat. Eff. 92 (1986) 151
- 1986DO1B Dover, Proc. Int. Nucl. Phys. Conf., Harrogate, U.K., No. 68, Vol. 2 (1986) 99
- 1986ER1A R.A. Eramzhyan, B.S. Ishkhanov, I.M. Kapitonov and V.G. Neudatchin, Phys. Rept. 136 (1986) 229
- 1986FI1A V.A. Filimonov, Czech. J. Phys. 36 (1986) 431
- 1986FL1A Flerov, in Harrogate, Suppl. 1 (1986)
- 1986FL1B Flerov, in Dubna (1986) 9
- 1986GA1H A. Gal, AIP Conf. Proc. 150 (1986) 127
- 1986GL1A Glaudemans, AIP Conf. Proc. 142 (1986) 316
- 1986GLZU Yu.A. Glukhov, E.I. Koshchy, N.S.Lutsay, Yu.G. Mashkarov, E.Yu. Nikolsky, A.T. Rudchik, S.B. Sakuta and K.F. Ustimenkov, in Kharkov (1986) 371
- 1986GLZV Yu.A. Glukhov, E.I. Koshchy, Yu.G. Mashkarov, E.Yu. Nikolsky, A.T. Rudchik, S.B. Sakuta and K.F. Ustimenkov, in Kharkov (1986) 370
- 1986GO1B Gorionov et al., in Kharkov (1986) 373
- 1986GO28 N.F. Golovanova and V.V. Kurovsky, Izv. Akad. Nauk SSSR Ser. Fiz. 50 (1986) 963; Bull. Acad. Sci. USSR Phys. Ser. 50 (1986) 131
- 1986HA13 Q. Haider and F.B. Malik, J. Phys. (London) G12 (1986) 537
- 1986HA1B B.G. Harvey, J. Phys. Colloq. (Paris) 47 (1986) C4-29
- 1986HAYU L.F. Hansen, Radiat. Eff. 92 (1986) 83
- 1986HO11 S. Homma and H. Tezuka, J. Phys. Soc. Jpn. 55 (1986) 780
- 1986IS04 Y. Iseri and M. Kawai, Phys. Rev. C34 (1986) 38
- 1986JI01 R.I. Jibuti, P.M. Imnadze and Sh.M. Tsiklauri, Yad. Fiz. 43 (1986) 834; Sov. J. Nucl. Phys. 43 (1986) 530
- 1986KA22 S. Kailas and S.K. Gupta, Phys. Rev. C34 (1986) 357
- 1986KO1A Kolesnikov et al., in Kharkov (1986) 225
- 1986KU11 Y. Kurihara, S. Date, A. Nakamura, H. Sato, H. Sumiyoshi and K. Yoshinada, Prog. Theor. Phys. 75 (1986) 1196
- 1986LA26 M. Lattuada, F. Riggi, C. Spitaleri, D. Vinciguerra, D. Miljanic, M. Zadro and J.Z. Yao, Nucl. Phys. A458 (1986) 493
- 1986LI1G Likhachev et al., in Kharkov (1986) 351

- 1986LI22 V.P. Likhachev, A.Yu. Buki, I.G. Evseev, A.A. Zayats, Yu.V. Vladimirov, S.A. Pashchuk, G.A. Savitsky, O.G. Savchuk, V.M. Khvastunov, V.A. Fartushny and V.B. Shostak, *Yad. Fiz.* 44 (1986) 1377; *Sov. J. Nucl. Phys.* 44 (1986) 895
- 1986MA19 J.F. Mateja, A.D. Frawley, L.C. Dennis and K. Sartor, *Phys. Rev. C* 33 (1986) 1649
- 1986MA1C L. Majling, J. Zofka, V.N. Fetisov and R.A. Eramzhyan, *Nucl. Phys. A* 450 (1986) 189c
- 1986MA1O MacDonald et al., in *Harrogate* (1986) C214
- 1986MA1W M. May, *Nucl. Phys. A* 450 (1986) 179c
- 1986MA48 D.M. Manley, B.L. Berman, W. Bertozzi, J.M. Finn, F.W. Hersman, C.E. Hyde-Wright, M.V. Hynes, J.J. Kelly, M.A. Kovash, S. Kowalski et al., *Phys. Rev. C* 34 (1986) 1214
- 1986MC1G D.J. McLean, D. Zubanov and M.N. Thompson, 11th AINSE Nucl. Phys. Conf., Melbourne, Vic., Australia, 3-5 Feb. 1986 (1986) 72
- 1986ME06 M.C. Mermaz, T. Suomijarvi, R. Lucas, B. Berthier, J. Matuszek, J.P. Coffin, G. Guillaume, B. Heusch, F. Jundt and F. Rami, *Nucl. Phys. A* 456 (1986) 186
- 1986ME1F D.F. Measday, *Czech. J. Phys.* 36 (1986) 395
- 1986MI24 K. Mikulas, K.A. Gridnev, E.F. Hefter, V.M. Semjonov and V.B. Subbotin, *Nuovo Cim. A* 93 (1986) 135
- 1986MU07 K. Murphy, R.C. Byrd, C.E. Floyd, P.P. Guss and R.L. Walter, *Nucl. Phys. A* 455 (1986) 525
- 1986NA15 K. Nakayama and G. Bertsch, *Phys. Rev. C* 34 (1986) 2190
- 1986OS08 V.I. Ostroumov, I.I. Loshchakov and A.I. Vdovin, *Izv. Akad. Nauk SSSR Ser. Fiz.* 50 (1986) 916; *Bull. Acad. Sci. USSR Phys. Ser.* 50 (1986) 83
- 1986PE05 J.P. Perroud, A. Perrenoud, J.C. Alder, B. Gabioud, C. Joseph, J.F. Loude, N. Morel, M.T. Tran, E. Winkelmann, H. Von Fellenberg et al., *Nucl. Phys. A* 453 (1986) 542
- 1986PO06 D.N. Poenaru, W. Greiner, K. Depta, M. Ivascu, D. Mazilu and A. Sandulescu, *At. Data Nucl. Data Tables* 34 (1986) 423
- 1986PO1G O. Portilho, P.S.C. Alencar and S.A. Coon, *Nucl. Phys. A* 450 (1986) 237c
- 1986RE13 B.A. Remington, G. Caskey, A. Galonsky, C.K. Gelbke, L. Heilbronn, J. Heltsley, M.B. Tsang, F. Deak, A. Kiss, Z. Seres et al., *Phys. Rev. C* 34 (1986) 1685
- 1986RO03 R. Rockmore and B. Saghai, *Phys. Rev. C* 33 (1986) 576
- 1986RO12 G. Royer, *J. Phys. (London)* G12 (1986) 623
- 1986RO1H Robson, *J. Phys. Soc. Jpn. Suppl.* 55 (1986) 491
- 1986RO27 M.S. Rowland and J.C. Robertson, *Radiat. Eff.* 96 (1986) 21
- 1986SA02 M. Sato, S.A. Coon, H.J. Pirner and J.P. Vary, *Phys. Rev. C* 33 (1986) 1062

- 1986SA30 H. Sato and Y. Okuhara, Phys. Rev. C34 (1986) 2171
- 1986SC1F P. Schluter, G. Soff and W. Greiner, Phys. Rev. C33 (1986) 1816
- 1986SC35 R.L. Schulte, J.M. Papazian and P.N. Adler, Nucl. Instrum. Meth. Phys. Res. B15 (1986) 550
- 1986SE04 K.K. Seth, S. Iversen, M. Kaletka, D. Barlow, A. Saha and R. Soundranayagam, Phys. Lett. B173 (1986) 397
- 1986SH1F W.Q. Shen, S.Z. Yin, Z.Y. Guo, W.L. Zhan, Y.T. Zhu, G.M. Jin, W.M. Qiao, E.C. Wu and C.L. Jiang, Chin. Phys. 6 (1986) 80
- 1986SH1V S.-H. Shi and X.-N. Jin, Commun. Theor. Phys. 5 (1986) 105
- 1986SIZS P.J. Simmonds, N.M. Clarke, K.I. Pearce, R.J. Griffiths, C.A. Ogilvie and M. Mannion, in Harrogate (1986) 315
- 1986SO10 L.G. Sobotka, D.G. Sarantites, H. Puchta, F.A. Dilmanian, M. Jaaskelainen, M.L. Halbert, J.H. Barker, J.R. Beene, R.L. Ferguson, D.C. Hensley et al., Phys. Rev. C34 (1986) 917
- 1986SY1A T.J.M. Symons, Nucl. Phys. A447 (1986) 157c
- 1986WA1H D.-Y. Wang, G.-M. Jin, L. Zhang, H.-K. Yue and X.-M. Wang, Phys. Energ. Fortis Phys. Nucl. 10 (1986) 68
- 1986WA1J X.-C. Wang, H. Takaki and H. Bando, Prog. Theor. Phys. 76 (1986) 865
- 1986WE1C G.D. Westfall, Nucl. Phys. A447 (1986) 591c
- 1986WI04 D.H. Wilkinson, Nucl. Phys. A452 (1986) 296
- 1986YA02 T. Yamada, K. Ikeda, H. Bando and T. Motoba, Phys. Lett. B172 (1986) 149
- 1986YA1D T. Yamada, K. Ikeda, T. Motoba and H. Bando, Nucl. Phys. A450 (1986) 333c
- 1986YA1F Y. Yamamoto, Prog. Theor. Phys. 75 (1986) 639
- 1986YU1A Y.-W. Yu, T. Motoba and H. Bando, Prog. Theor. Phys. 76 (1986) 861
- 1986ZI01 F. Zijderhand and C. Van Der Leun, Phys. Lett. B166 (1986) 389
- 1986ZO1A J. Zofka, Nucl. Phys. A450 (1986) 165c
- 1987AJ02 F. Ajzenberg-Selove, Nucl. Phys. A475 (1987) 1
- 1987AK1A Akhverdyan et al., in Panic (1987) 708
- 1987AN14 A.K. Ananikyan, E.A. Arakelyan, G.L. Bayatyan, G.S. Vartanyan, A.R. Voskanyan, K.T. Darbinyan, N.K. Grigoryan, S.G. Knyazyan, A.T. Margaryan, G.G. Marikyan et al., Yad. Fiz. 46 (1987) 401; Sov. J. NUcl. Phys. 46 (1987) 208
- 1987AR19 S.E. Arnell, S. Mattsson, H.A. Roth, M. Rydehell, O. Skeppstedt, A. Johnson, J. Nyberg, A. Kerek and A. Nilsson, Phys. Scr. 36 (1987) 214
- 1987AR1C Arnould, Phil. Trans. Roy. Soc. (London) 323 (1987) 251

- 1987AR22 E. Arnold, J. Bonn, R. Gegenwarth, W. Neu, R. Neugart, E.-W. Otten, G. Ulm, K. Wendt and ISOLDE Collaboration, Phys. Lett. B197 (1987) 311
- 1987AU1A J. Audouze, J. Astrophys. Astron. 8 (1987) 147
- 1987AU1C Auchev et al., in Yurmala (1987) 395
- 1987BA1I B.F. Bayman and Y.C. Tang, Phys. Rept. 147 (1987) 155
- 1987BA2K H. Bando, T. Yamada and J. Zofka, Phys. Rev. C36 (1987) 1640
- 1987BA38 G.J. Balster, P.C.N. Crouzen, P.B. Goldhoorn, R.H. Siemssen and H.W. Wilschut, Nucl. Phys. A468 (1987) 93
- 1987BA54 F.C. Barker, Aust. J. Phys. 40 (1987) 307
- 1987BEYI A.V. Belozyorov, C. Borcea, Z. Dlouhy, A.M. Kalinin, N.H. Chau and Yu.E. Penionzhkevich, JINR-E15-87-733 (1987)
- 1987BI1C Bimbot et al., in Panic (1987) 370
- 1987BO1L A.R. Bodmer and Q.N. Usmani, Nucl. Phys. A463 (1987) 221c
- 1987BO1N Boyarinov et al., in Panic (1987) 244
- 1987BO1O A.R. Bodmer and Q.N. Usmani, Nucl. Phys. A468 (1987) 653
- 1987BO23 R. Bougault, D. Horn, C.B. Chitwood, D.J. Fields, C.K. Gelbke, D.R. Klesch, W.G. Lynch, M.B. Tsang and K. Kwiatkowski, Phys. Rev. C36 (1987) 830
- 1987BU1A Burkov, Glozman, Zhusupov and Neudachin, in Yurmala (1987) 515
- 1987BU27 N.T. Burtebaev, A.D. Duisebaev, V.S. Sadkovskii and G.A. Feofilov, Izv. Akad. Nauk SSSR Ser. Fiz. 51 (1987) 615; Bull. Acad. Sci. USSR Phys. Ser. 51 (1987) 191
- 1987BUZZ M. Burlein, H.T. Fortune, A.H. Wuosmaa, P.H. Kutt, R. Gilman, R. Sherr and J.D. Brown, Bull. Amer. Phys. Soc. 32 (1987) 1061, EG1
- 1987CH26 Z. Chen, C.K. Gelbke, J. Pochodzalla, C.B. Chitwood, D.J. Fields, W.G. Gong, W.G. Lynch and M.B. Tsang, Nucl. Phys. A473 (1987) 564
- 1987CU01 J. Cugnon, Nucl. Phys. A462 (1987) 751
- 1987DA25 N.X. Dai, B.J. Qi, Y.J. Mao, F. Zhuang, J.Z. Yao and X.Z. Wang, Chin. J. Nucl. Phys. 9 (1987) 103
- 1987DE37 F. Deak, A. Kiss, Z. Seres, G. Caskey, A. Galonsky and B. Remington, Nucl. Instrum. Meth. Phys. Res. A258 (1987) 67
- 1987DE43 H. De Vries, C.W. De Jager and C. De Vries, At. Data Nucl. Data Tables 36 (1987) 495
- 1987DW1A R. Dwyer and P. Meyer, Astrophys. J. 322 (1987) 981
- 1987FA09 M. Fatyga, K. Kwiatkowski, V.E. Viola, W.G. Wilson, M.B. Tsang, J. Pochodzalla, W.G. Lynch, C.K. Gelbke, D.J. Fields, C.B. Chitwood et al., Phys. Rev. Lett. 58 (1987) 2527

- 1987FE1A E.-P. Feng, Q. Wang, Y.-T. Zhu, X. Yin, H.-B. Miao, S.-M. Sun, S.-L. Li, Z.-L. Wu, G.-Y. Fan, Y.-X. Xie et al., *Chin. Phys.* 7 (1987) 121
- 1987FR1B B. Frois and C.N. Papanicolas, *Ann. Rev. Nucl. Part. Sci.* 37 (1987) 133
- 1987GA08 E. Gadioli and E. Gadioli Erba, *Z. Phys.* A327 (1987) 81
- 1987GI1C W.R. Gibbs and B.F. Gibson, *Ann. Rev. Nucl. Part. Sci.* 37 (1987) 411
- 1987GLZX Yu.A. Glukhov, E.I. Koshchy, Yu.G. Mashkarov, E.Yu. Nikolsky, A.T. Rudchik and S.B. Sakuta, in *Yurmala* (1987) 382
- 1987GO17 P.L. Gonthier, B. Bouma, P. Harper, R. Ramaker, D.A. Cebra, Z.M. Koenig, D. Fox and G.D. Westfall, *Phys. Rev.* C35 (1987) 1946
- 1987GO1Q Golovkov, Vasina and Yakovlev, in *Yurmala* (1987) 408
- 1987GO25 M.G. Gornov, Yu.B. Gurov, V.P. Koptev, P.V. Morokhov, K.O. Oganesyanyan, B.P. Osipenko, V.A. Pechkurov, V.I. Savelev, F.M. Sergeev, A.A. Khomutov et al., *Pisma Zh. Eksp. Teor. Fiz.* 45 (1987) 205; *JETP Lett.* (USSR) 45 (1987) 252
- 1987GOZN M.G. Gornov, P.V. Morokhov, V.A. Pechkurov, F.M. Sergeev, A.A. Khomutov and R.R. Shafigullin, in *Yurmala* (1987) 269
- 1987GR11 R.E.L. Green, R.G. Korteling, J.M. D'Auria, K.P. Jackson and R.L. Helmer, *Phys. Rev.* C35 (1987) 1341
- 1987GR1G Gram et al., in *Panic* (1987) 362
- 1987HA01 Y. Haneishi and T. Fujita, *Phys. Rev.* C35 (1987) 70
- 1987HA1R Hansen, *Nature* 328 (1987) 476
- 1987HA30 P.G. Hansen and B. Jonson, *Europhys. Lett.* 4 (1987) 409
- 1987HAZS L.F. Hansen, F.S. Dietrich and R.L. Walter, *Bull. Amer. Phys. Soc.* 32 (1987) 1567, DB8
- 1987HE1H T.K. Hemmick, D. Elmore, P.W. Kubik, S.L. Olsen, T. Gentile, D. Nitz, D. Ciampa, H. Kagan, P. Haas, P.F. Smith et al., *Nucl. Instrum. Meth. Phys. Res.* B29 (1987) 389
- 1987HO1D R. Hofstadter, *AIP Conf. Proc.* 161 (1987) 23
- 1987HO1F R. Hofstadter, *Aust. Phys.* 24 (1987) 236
- 1987HO1L Y.K. Ho, *Chin. Phys. Lett.* 4 (1987) 69
- 1987HY01 C.E. Hyde-Wright, W. Bertozzi, T.N. Buti, J.M. Finn, F.W. Hersman, M.V. Hynes, M.A. Kovash, J.J. Kelly, S. Kowalski, J. Lichtenstadt et al., *Phys. Rev.* C35 (1987) 880
- 1987IK1B Ikeda and Yamada, in *Panic* (1987) 568
- 1987IN1A K.G.W. Inn, S. Raman, B.M. Coursey, J.D. Fassett and R.L. Walker, *Nucl. Instrum. Meth. Phys. Res.* B29 (1987) 27

- 1987JA06 B.V. Jacak, G.D. Westfall, G.M. Crawley, D. Fox, C.K. Gelbke, L.H. Harwood, B.E. Hasselquist, W.G. Lynch, D.K. Scott, H. Stocker et al., Phys. Rev. C35 (1987) 1751
- 1987JI1A G.-Y. Jiang and X.-N. Jin, Phys. Energ. Fortis Phys. Nucl. 11 (1987) 226
- 1987KA13 M. Kanazawa, S. Homma, M. Koike, Y. Murata, H. Okuno, F. Soga, N. Yoshikawa and A. Sasaki, Phys. Rev. C35 (1987) 1828
- 1987KA36 K. Kadija, G. Paic, B. Antolkovic, A. Djaloic and J. Bojowald, Phys. Rev. C36 (1987) 1269
- 1987KI1C H.R. Kissener, I. Rotter and N.G. Goncharova, Fortschr. Phys. 35 (1987) 277
- 1987KIZY A. Kiss, F. Deak, Z. Seres, G. Caskey, A. Galonsky, B. Remington, C.K. Gelbke, M.B. Tsang and J.J. Kolata, Bull. Amer. Phys. Soc. 32 (1987) 1551, BB11
- 1987KO15 T. Kozik, J. Buschmann, K. Grotowski, H.J. Gils, N. Heide, J. Kiener, H. Klewe-Nebenius, H. Rebel, S. Zagromski, A.J. Cole et al., Z. Phys. A326 (1987) 421
- 1987KO1K Kolalis et al., in Yurmala (1987) 324
- 1987KO1Z Kobayashi et al., in Panic (1987) 478
- 1987KU05 G. Kuechler, A. Richter and W. von Witsch, Z. Phys. A326 (1987) 447
- 1987KU1I Kurihara and Faessler, in Panic (1987) 662
- 1987KU1L M. Kusakabe, T.L. Ku, J.R. Southon, J.S. Vogel, D.E. Nelson, C.I. Measures and Y. Nozaki, Nucl. Instrum. Meth. Phys. Res. B29 (1987) 306
- 1987KU23 Y. Kuno, K. Nagamine and T. Yamazaki, Nucl. Phys. A475 (1987) 615
- 1987KW01 E. Kwasniewicz and J. Kisiel, J. Phys. (London) G13 (1987) 121
- 1987KW02 K. Kwiatkowski, Nucl. Phys. A471 (1987) 271c
- 1987KW03 E. Kwasniewicz and J. Kisiel, Rev. Roum. Phys. 32 (1987) 607
- 1987LE1F R.J. Leeper, K.H. Kim, D.E. Hebron, N.D. Wing and E. Norbeck, Nucl. Instrum. Meth. Phys. Res. B24-25 (1987) 695
- 1987LE32 Yu.B. Lepikhin, V.A. Smirnitsky and V.A. Sheinkman, Pisma Zh. Eksp. Teor. Fiz. 46 (1987) 219; JETP Lett. 46 (1987) 275
- 1987LE33 F.S. Levin, Nucl. Phys. A463 (1987) 487c
- 1987LU1B Lubovoi and Chitanava, in Yurmala (1987) 512
- 1987LY04 W.G. Lynch, Nucl. Phys. A471 (1987) 309c
- 1987MA1I Matthews et al., in Panic (1987) 360
- 1987MA2C Malaney and Fowler, OAP-680, To be published in Origin and Distribution of the Elements (1987)
- 1987MI38 M. Mian, Phys. Rev. C35 (1987) 1463

- 1987MU03 J.A. Muzycka and B.I. Pustyl'nik, *Yad. Fiz.* 45 (1987) 90; *Sov. J. Nucl. Phys.* 45 (1987) 57
- 1987MU1D Muzitshka, Pustil'nik, and Avdechikov, in *Dubna* (1987) 589
- 1987NA01 M.N. Namboodiri, R.K. Choudhury, L. Adler, J.D. Bronson, D. Fabris, U. Garg, P.L. Gonthier, K. Hagel, D.R. Haenni, Y.W. Lui et al., *Phys. Rev. C* 35 (1987) 149
- 1987OC01 J.S. O'Connell, W.R. Dodge, J.W. Lightbody, Jr., X.K. Maruyama, J.-O. Adler, K. Hansen, B. Schroder, A.M. Bernstein, K.I. Blomqvist, B.H. Cottman et al., *Phys. Rev. C* 35 (1987) 1063
- 1987OT1C Otten, *Bull. Amer. Phys. Soc.* 32 (1987) 1101
- 1987PE1C Penionshkevich, in *Dubna* (1987) 364
- 1987PI1B Pile et al., in *Panic* (1987) 594
- 1987PI1C Pile et al., *Bull. Amer. Phys. Soc.* 32 (1987) 1560
- 1987PO03 J. Pochodzalla, C.K. Gelbke, W.G. Lynch, M. Maier, D. Ardouin, H. Delagrange, H. Doubre, C. Gregoire, A. Kyanowski, W. Mittig et al., *Phys. Rev. C* 35 (1987) 1695
- 1987PO1H B. Povh, *Prog. Part. Nucl. Phys.* 18 (1987) 183
- 1987RA32 J. Rapaport, *Can. J. Phys.* 65 (1987) 574
- 1987RO25 C. Rolfs, H.P. Trautvetter and W.S. Rodney, *Rept. Prog. Phys.* 50 (1987) 233
- 1987SA15 H. Sagawa and H. Toki, *J. Phys. (London)* G13 (1987) 453
- 1987SE05 K.K. Seth, M. Artuso, D. Barlow, S. Iversen, M. Kaletka, H. Nann, B. Parker and R. Soundranayagam, *Phys. Rev. Lett.* 58 (1987) 1930
- 1987SH1K Shimoura and Tanihata, in *Panic* (1987) 480
- 1987SH23 W.Q. Shen, Y.T. Zhu, W.L. Zhan, Z.Y. Guo, S.Z. Yin, W.M. Qiao and X. Yin, *Nucl. Phys. A* 472 (1987) 358
- 1987SI1C Siemssen, *Proc. Beijing Int. Symp. on Phys. at Tandem, 1986* (1987) 317
- 1987SN01 K. Sneppen, *Nucl. Phys. A* 470 (1987) 213
- 1987SO13 L.G. Sobotka, D.G. Sarantites, Ze Li, E.L. Dines, M.L. Halbert, D.C. Hensley, R.P. Schmitt, Z. Majka, G. Nebbia, H.C. Griffin et al., *Nucl. Phys. A* 471 (1987) 131c
- 1987SO15 L.G. Sobotka, D.G. Sarantites, Ze Li, E.L. Dines, M.L. Halbert, D.C. Hensley, J.C. Lisle, R.P. Schmitt, Z. Majka, G. Nebbia et al., *Phys. Rev. C* 36 (1987) 2713
- 1987ST01 G.S.F. Stephans, R.V.F. Janssens, D.G. Kovar and B.D. Wilkins, *Phys. Rev. C* 35 (1987) 614
- 1987SU06 T. Suzuki, D.F. Measday and J.P. Roalsvig, *Phys. Rev. C* 35 (1987) 2212
- 1987TAZU I. Tanihata, H. Hamagaki, O. Hashimoto, Y. Shida, O. Yamakawa, T. Kobayashi, K. Sugimoto and N. Takahashi, in *Panic* (1987) 474; *LBL-22820* (1987) 82
- 1987TE1E Tezuka, Homma and Fujii, in *Panic* (1987) 688

- 1987TR01 H.-J. Trost, P. Lezoch and U. Strohbusch, Nucl. Phys. A462 (1987) 333
- 1987TR05 W. Trautmann, K.D. Hildenbrand, U. Lynen, W.F.J. Muller, H.J. Rabe, H. Sann, H. Stelzer, R. Trockel, R. Wada, N. Brummund et al., Nucl. Phys. A471 (1987) 191c
- 1987VA1I Valiev et al., in Yurmala (1987) 346
- 1987VI14 V.E. Viola, Nucl. Phys. A471 (1987) 53c
- 1987VO08 V.I. Voloshchuk, I.V. Dogyust, V.V. Zolenko, V.V. Kirichenko and A.F. Khodyachikh, Ukr. Fiz. Zh. 32 (1987) 651
- 1987VO1F Voronaova et al., in Yurmala (1987) 581
- 1987VOZU V.T. Voronchev, B.G. Kaganov and V.M. Krasnopolskii, in Yurmala (1987) 163
- 1987WA09 R. Wada, K.D. Hildenbrand, U. Lynen, W.F.J. Muller, H.J. Rabe, H. Sann, H. Stelzer, W. Trautmann, R. Trockel, N. Brummund et al., Phys. Rev. Lett. 58 (1987) 1829
- 1987WA25 R.E. Warner, F.G. Johnson, C.P. Browne, A. Rollefson, A. Galonsky and A. Nadasen, Nucl. Phys. A472 (1987) 522
- 1987WA36 X.-C. Wang, H. Bando and H. Takaki, Z. Phys. A 327 (1987) 59
- 1987YA16 Yu.P. Yakovlev, Yad. Fiz. 46 (1987) 459; Sov. J. Nucl. Phys. 46 (1987) 244
- 1987YA1C Yamamoto, in Panic (1987) 582
- 1987YA1I Yamada, Ikeda, Bando and Motoba, in Panic (1987) 570
- 1987YA1M Y. Yamamoto, Phys. Rev. C36 (1987) 2166
- 1987YI1A S.-Z. Yin, Y.-T. Zhu, W.-Q. Shen, Z.-Y. Guo, W.-L. Zhan, W.-M. Qiao, E.-C. Wu and Z.-H. Zheng, Phys. Energ. Fortis and Phys. Nucl. 11 (1987) 259
- 1987ZA07 M. Zadro, D. Miljanic, M. Lattuada, F. Riggi and C. Spitaleri, Nucl. Phys. A474 (1987) 373
- 1987ZI01 F. Zijderhand, S.W. Kikstra, S.S. Hanna and C. van der Leun, Nucl. Phys. A462 (1987) 205
- 1988AR05 N. Arena, Seb. Cavallaro, G. Fazio, G. Giardina, A. Italiano and F. Mezzanares, Europhys. Lett. 5 (1988) 517
- 1988ARZU K.P. Artemov, M.S. Golovkov, V.Z. Goldberg, V.P. Rudakov, I.N. Serikov, V.A. Timofeev, J. Schmider, M. Madeya and Ya. Yakel, in Baku (1988) 381
- 1988BA82 H. Bando, Nucl. Phys. A478 (1988) 697c
- 1988BEYJ A.V. Belozarov, K. Borchia, I. Vintsour, Z. Dlougy, N.K. Tyau and Yu.Eh. Penionzhkevich, in Baku (1988) 380
- 1988BL09 C. Bloch, W. Benenson, A.I. Galonsky, E. Kashy, J. Heltsley, L. Heilbronn, M. Lowe, R.J. Radtke, B. Remington, J. Kassagi et al., Phys. Rev. C37 (1988) 2469
- 1988BO47 K. Bodek, B. Bruggemann, J. Krug, P. Lekkas, W. Lubcke, H. Ruhl, M. Steinke, M. Stephan, A. Szczurek and D. Kamke, Few-Body Syst. 3 (1988) 135

- 1988CA06 G. Caskey, L. Heilbronn, B. Remington, A. Galonsky, F. Deak, A. Kiss and Z. Seres, *Phys. Rev. C* 37 (1988) 696
- 1988CH04 R.J. Charity, D.R. Bowman, Z.H. Liu, R.J. McDonald, M.A. McMahan, G.J. Wozniak, L.G. Moretto, S. Bradley, W.L. Kehoe and A.C. Mignerey, *Nucl. Phys. A* 476 (1988) 516
- 1988CH48 R.E. Chrien, *Nucl. Phys. A* 478 (1988) 705c
- 1988DI02 S.S. Dietrich and B.L. Berman, *At. Data Nucl. Data Tables* 38 (1988) 199
- 1988GIZU Yu.R. Gismatullin, A.A. Melentev, V.I. Ostroumov, A.M. Petukhov and M.A. Stalevich, in *Baku* (1988) 293
- 1988GO02 S.A. Goncharov, A.M. Mukhamedzhanov, E.A. Romanovsky, G.E. Valiev, I.R. Gulamov, Yu.I. Denisov, T. Iskhakov, A. Karakhodzhaev, G.K. Nie, R. Yarmukhamedov et al., *Czech. J. Phys. B* 38 (1988) 12
- 1988GO1F Goryonov et al., in *Baku* (1988) 365
- 1988GOZB S.A. Goncharov, E.A. Romanovsky and N.K. Timofeyuk, in *Baku* (1988) 349
- 1988GUZW I.R. Gulamov, A.M. Mukhamedzhanov and G.K. Ni, in *Baku* (1988) 300
- 1988HA44 R. Hausmann, *Nucl. Phys. A* 479 (1988) 247c
- 1988HE08 R. Henneck, C. Gysin, P. Haffter, M. Hammans, W. Lorenzon, M.A. Pickar, I. Sick and S. Burzynski, *Phys. Rev. C* 37 (1988) 2224
- 1988JI1A G.-Y. Jiang and X.-N. Jin, *Commun. Theor. Phys.* 9 (1988) 33
- 1988JO1C B. Jonson, S. Mattsson, G. Nyman, O. Tengblad, M.J.G. Borge, P.G. Hansen and K. Riisager, *AIP Conf. Proc.* 164 (1988) 223
- 1988KA1L Kademsky, Lukyanovich, Rudchik and Skalnitsky, in *Baku* (1988) 462
- 1988KA1N S. Katsanevas, C. Kourkouvelis, A. Markou, L.K. Resvanis, S. Tzamarias, G. Voulgaris, M. Binkley, B. Cox, J. Enagonio, C. Hojvat et al., *Phys. Rev. Lett.* 60 (1988) 2121
- 1988KH03 K.S. Myint and Y. Akaishi, *Prog. Theor. Phys.* 79 (1988) 454
- 1988KI05 J.M. Kidd, P.J. Lindstrom, H.J. Crawford and G. Woods, *Phys. Rev. C* 37 (1988) 2613
- 1988KR11 L. Kraus, A. Boucenna, I. Linck, B. Lott, R. Rebmeister, N. Schulz, J.C. Sens, M.C. Mermaz, B. Berthier, R. Lucas et al., *Phys. Rev. C* 37 (1988) 2529
- 1988KW02 E. Kwasniewicz and J. Kisiel, *Acta Phys. Pol.* B19 (1988) 141
- 1988MA1G L. Majling, J. Zofka, V.N. Fetisov and R.A. Eramzhyan, *Phys. Lett. B* 202 (1988) 489
- 1988MI03 D. Mikolas, B.A. Brown, W. Benenson, L.H. Harwood, E. Kashy, J.A. Nolen, Jr., B. Sherrill, J. Stevenson, J.S. Winfield, Z.Q. Xie et al., *Phys. Rev. C* 37 (1988) 766
- 1988MI1G D. Mikolas, B.A. Brown, W. Benenson, Y. Chen, M.S. Curtin, L.H. Harwood, E. Kashy, J.A. Nolen, Jr., M. Samuel, B. Sherrill et al., *AIP Conf. Proc.* 164 (1988) 708

1988MO1B T. Motoba, Nucl. Phys. A470 (1988) 227c
1988OR1C Ormand and Brown, NBI-87-63 (1988)
1988PO1D Potvin et al., Bull. Amer. Phys. Soc. 33 (1988) 1219
1988PO1F Ponkratenko, Nemets and Rudchik, in Baku (1988) 365
1988POZS N.A.F.M. Poppelier, J.H. de Vries, A.A. Wolters and P.W.M. Glaudemans, AIP Conf. Proc. 164 (1988) 334
1988POZZ J. Pouliot, Y.D. Chan, A. Dacal, B.A. Harmon, R. Knop, M.E. Ortiz, E. Plagnol, R.G. Stokstad, C. Moisan, L. Potvin et al., Bull. Amer. Phys. Soc. 33 (1988) 1179
1988RE1B R. Rebolo, P. Molaro, C. Abia and J.E. Beckman, Astron. Astrophys. 193 (1988) 193
1988RU01 V.A. Rubchenya and S.G. Yavshits, Z. Phys. A329 (1988) 217
1988SA04 M. Samuel, B.A. Brown, D. Mikolas, J. Nolen, B. Sherrill, J. Stevenson, J.S. Winfield and Z.Q. Xie, Phys. Rev. C37 (1988) 1314
1988SA19 H. Sato, Phys. Rev. C37 (1988) 2902
1988SA2H Sale et al., Bull. Amer. Phys. Soc. 33 (1988) 1101
1988SEZJ K.K. Seth, AIP Conf. Proc. 164 (1988) 324
1988SH1E Shvedov, Nemets and Rudchik, in Baku (1988) 351
1988ST06 J. Stevenson, B.A. Brown, Y. Chen, J. Clayton, E. Kashy, D. Mikolas, J. Nolen, M. Samuel, B. Sherrill, J.S. Winfield et al., Phys. Rev. C37 (1988) 2220
1988TA1A I. Tanihata, Nucl. Phys. A478 (1988) 795c
1988TA29 H. Tamura, W. Bruckner, H. Dobbeling, R.S. Hayano, T. Ishikawa, M. Iwasaki, T. Motoki, H. Outa, S. Paul, B. Povh et al., Nucl. Phys. A479 (1988) 161c
1988TRZY D.E. Trcka, S.P. Van Verst, A.D. Frawley, K.W. Kemper, J.D. Fox, V. Hnizdo and E.G. Myers, Bull. Amer. Phys. Soc. 33 (1988) 1101, KJ12
1988TS03 M.B. Tsang, W.G. Lynch, R.M. Ronningen, Z. Chen, C.K. Gelbke, T. Nayak, J. Pochodzalla, F. Zhu, M. Tohyama, W. Trautmann et al., Phys. Rev. Lett. 60 (1988) 1479
1988VA03 A.G.M. van Hees, A.A. Wolters and P.W.M. Glaudemans, Nucl. Phys. A476 (1988) 61
1988WA1B T. Walcher, Nucl. Phys. A479 (1988) 63c
1988WO04 A.A. Wolters, A.G.M. van Hees and P.W.M. Glaudemans, Europhys. Lett. 5 (1988) 7
1990AJ01 F. Ajzenberg-Selove, Nucl. Phys. A506 (1990) 1

