

Energy Levels of Light Nuclei $A = 14$

F. Ajzenberg-Selove

University of Pennsylvania, Philadelphia, Pennsylvania 19104-6396

Abstract: An evaluation of $A = 13-15$ was published in *Nuclear Physics A523* (1991), p. 1. This version of $A = 14$ differs from the published version in that we have corrected some errors discovered after the article went to press. The introduction and introductory tables have been omitted from this manuscript. [Reference](#) key numbers have been changed to the NNDC/TUNL format.

(References closed July 1, 1990)

The original work of Fay Ajzenberg-Selove was supported by the US Department of Energy [DE-FG02-86ER40279]. Later modification by the TUNL Data Evaluation group was supported by the US Department of Energy, Office of High Energy and Nuclear Physics, under: Contract No. DEFG05-88-ER40441 (North Carolina State University); Contract No. DEFG05-91-ER40619 (Duke University).

Table of Contents for $A = 14$

Below is a list of links for items found within the PDF document. The introductory [Table 2](#) is available on this website via the link.

A. Nuclides: [\$^{14}\text{He}\$](#) , [\$^{14}\text{Li}\$](#) , [\$^{14}\text{Be}\$](#) , [\$^{14}\text{B}\$](#) , [\$^{14}\text{C}\$](#) , [\$^{14}\text{N}\$](#) , [\$^{14}\text{O}\$](#) , [\$^{14}\text{F}\$](#) , [\$^{14}\text{Ne}\$](#) , [\$^{14}\text{Na}\$](#) , [\$^{14}\text{Mg}\$](#)

B. Tables of Recommended Level Energies:

[Table 14.1](#): Energy levels of ^{14}B

[Table 14.3](#): Energy levels of ^{14}C

[Table 14.10](#): Energy levels of ^{14}N

[Table 14.22](#): Energy levels of ^{14}O

C. [References](#)

D. Figures: [\$^{14}\text{B}\$](#) , [\$^{14}\text{C}\$](#) , [\$^{14}\text{N}\$](#) , [\$^{14}\text{O}\$](#) , [Isobar diagram](#)

E. Erratum to the Publication: [PS](#) or [PDF](#)

¹⁴He
(Not illustrated)

¹⁴He has not been observed: see (1989OG1B).

¹⁴Li
(Not illustrated)

¹⁴Li has not been observed. The calculated mass excess is 72.29 MeV: see (1981AJ01). ¹⁴Li is then particle unstable with respect to decay into ¹³Li + n and ¹²Li + 2n by 3.9 and 3.2 MeV, respectively [see, however, ¹³Li]. (1985PO10) calculate [in a (0 + 1) $\hbar\omega$ model space] that the first four states of ¹⁴Li at 0, 0.75, 1.22 and 1.48 MeV have, respectively, $J^\pi = 2^-, 4^-, 3^-$ and 1^- . See also (1986AL09, 1989OG1B) and (1988POZS; theor.).

¹⁴Be
(Fig. 5)

¹⁴Be has been observed in the ¹⁴C(π^-, π^+)¹⁴B reaction (1984GI09), in the interaction of 30 MeV/A ¹⁸O ions with ¹⁸¹Ta (1986CU01) and in the spallation of thorium by 800 MeV protons (1988WO09). See also (1986AJ01). The atomic mass excess reported by (1984GI09) is 40.10 ± 0.13 MeV but it is not clear that the ground state was observed. (1988WO09) report an atomic mass excess of 39.74 ± 0.14 MeV which we adopt. ¹⁴Be is then bound by 3.0 and 1.12 MeV, respectively, with respect to decay into ¹³Be + n and ¹²Be + 2n [see, however, ¹³Be].

¹⁴Be decays by β^- emission to states in ¹⁴B. Its half-life is 4.2 ± 0.7 ms (1986CU01), 4.35 ± 0.17 ms (1988DU09). We adopt the latter value. The branching ratios for 0n, 1n and 2n emission are 0.14 ± 0.03 , 0.81 ± 0.04 and 0.05 ± 0.02 (1988DU09). We remind the reader that the two bound states of ¹⁴B are the ground state [$J^\pi = 2^-$] and an excited state with $J^\pi = (1^-)$. The binding energies of 1n and 2n in ¹⁴B are, respectively, 0.97 and 5.85 MeV: see Fig. 5.

The interaction cross section at 790 MeV/A for ¹⁴Be ions on C is reported by (1988TA10) who also derive the interaction and the r.m.s. radii for the nucleon distribution in ¹⁴Be. See also (1989BE03; theor.) and (1989SA10). A calculation in a (0 + 1) $\hbar\omega$ model space suggests that the first four states of ¹⁴Be calculated to be at 0, 1.95, 3.67 and 5.30 MeV have $J^\pi = 0^+, 2^+, 4^+, 2^+$, respectively (1985PO10). See also (1986AN07, 1986WI04, 1987AJ1A, 1988MI1G, 1988TA1N, 1989AJ1A, 1989DE52, 1989TA1K, 1989TA2S, 1989VOZM) and (1987BL18, 1987SA15, 1987YA16, 1989PO1K, 1990BR1S, 1990LO10; theor.).

¹⁴B
(Figs. 1 and 5)

GENERAL (See also (1986AJ01)).

Complex reactions involving ¹⁴B: (1986BI1A, 1987SA25, 1988AS1C, 1988RU01, 1989AS1B, 1989YO02)

Pion capture and reactions: (1983AS01, 1984AS05)

Hypernuclei: (1986ME1F, 1988MA1G, 1989BA92)

Other topics: (1984VA06, 1986AN07, 1989PO1K, 1990RE04)

Ground state of ¹⁴B: (1987VA26, 1990LO10)

Interaction cross sections at 790 MeV/A for ¹⁴B ions on Be, C and Al are reported by (1988TA10) [see also for interaction and r.m.s. radii for the nucleon distribution in ¹⁴B]. See also (1989SA10).

1. ¹⁴B(β^-)¹⁴C $Q_m = 20.64$

¹⁴B has a half-life of 16.1 ± 1.2 ms (1974AL11), 12.8 ± 0.8 ms (1986CU01): the weighted mean is 13.8 ± 1.0 ms and we adopt it. The nature of the decay [see Table 14.2] fixes J^π of ¹⁴B to be 2^- (1974AL11). See also (1989PO1K; theor.).

2. ¹⁴C(π^-, γ)¹⁴B $Q_m = 118.92$

A single strong transition is observed in this pion capture cross section to a state in ¹⁴B at $E_x = 2.15 \pm 0.17$ MeV, $\Gamma = 1.0 \pm 0.5$ MeV, with $J^\pi = 2^-$. The relative branching ratio of the ground state [2^-] to this second 2^- state is < 0.1 . The data are also suggestive of the population of 2^- and 1^- states in the $E_x = 5 - 7$ MeV region (1983BA36).

3. ¹⁴C(n, p)¹⁴B $Q_m = -19.86$

Ground-state angular distributions have been reported at $E_n = 65$ MeV (1986DR1F, 1988DRZZ; prelim.).

4. ¹⁴C(⁷Li, ⁷Be)¹⁴B $Q_m = -21.51$

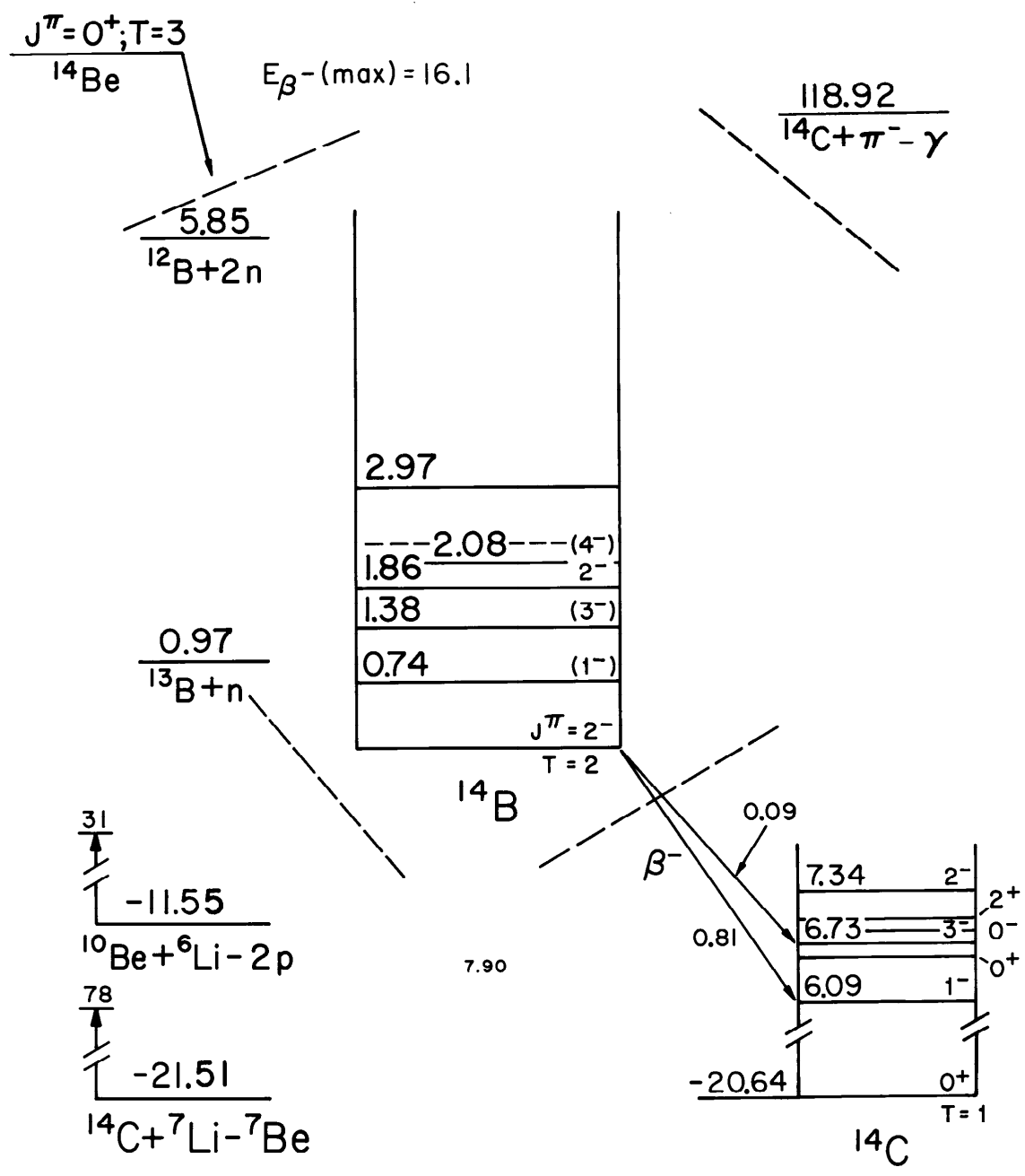

Figure 1: Energy levels of ^{14}B . For notation see Fig. 2.

Table 14.1: Energy levels of ^{14}B

E_x (MeV \pm keV)	$J^\pi; T$	$\tau_{1/2}$ (ms) or Γ (MeV)	Decay	Reactions
g.s. ^a	$2^-; 2$	$\tau_{1/2} = 13.8 \pm 1.0$ ms	β^-	1, 3, 4, 5
0.74 ± 40	$(1^-); 2$	$\Gamma = 1.0 \pm 0.5$ MeV		4
1.38 ± 30	$(3^-); 2$			4
1.86 ± 70 ^b	$2^-; 2$			2, 4
2.08 ± 50	$(4^-); 2$			4
(2.32 ± 40)				4
2.97 ± 40				4
^c				

^a See also footnote ^c to Table 14.3.

^b It is not clear that the states reported in reactions 2 and 4 are the same states. The level structure of ^{14}B should be studied further. I am indebted to Prof. F.C. Barker for his comments.

^c See reaction 2.

Table 14.2: Beta decay of ^{14}B ^a

Decay to $^{14}\text{C}^*$ (MeV)	J^π	Branch (%)	$\log ft$ ^e
0	0^+	(5 ± 3) ^c	(6.1 ± 0.3)
6.09 ^b	1^-	81 ± 9	4.16 ± 0.06
6.73	3^-	$8.6_{-4.0}^{+1.7}$	$5.04_{-0.08}^{+0.27}$
7.34	2^-	< 11 ^d	> 4.8

^a (1974AL11).

^b $E_{\beta^-}(\text{max}) = 14.0 \pm 0.7$ MeV to this state.

^c This branch has not been observed. It is assumed to be $(5 \pm 3)\%$ in the calculation of the branching ratios to $^{14}\text{C}^*$ (6.09, 6.73).

^d This branch has not been observed: the upper limit is shown. In the calculations of the branching ratios to $^{14}\text{C}^*$ (6.09, 6.73) a value $(5 \pm 5)\%$ was used.

^e M.J. Martin, private communication.

^{14}B states with $0 < E_x < 3$ MeV have been populated in this reaction at $E(^7\text{Li}) = 52$ MeV: see Table 14.1. Similarities in the relative intensities of $^{14}\text{B}^*(0, 0.74, 1.38, 1.82, 2.08)$ and of $^{12}\text{B}^*(1.67, 2.62, 3.39, 4.30, 4.52)$ [populated in $^{12}\text{C}(^7\text{Li}, ^7\text{Be})^{12}\text{B}$], and the similarity in the ΔE_x of these ^{12}B states with the E_x of the ^{14}B states suggest that they have the same J^π (1973BA34).

5. $^{14}\text{C}(^{14}\text{C}, ^{14}\text{N})^{14}\text{B}$ $Q_m = -20.49$

The work quoted in (1986AJ01) has not been published.

¹⁴C
(Figs. 2 and 5)

GENERAL (See also (1986AJ01)).

Nuclear models: (1985KW02, 1985MI23, 1986GU1F, 1987KI1C, 1988FL1A, 1988WO04, 1989PO1K, 1989SI1D, 1989WO1E)

Special states: (1985BA75, 1985GO1A, 1986AN07, 1987BL15, 1987BL18, 1987KI1C, 1989AM01, 1989RA17)

Electromagnetic transitions and giant resonances: (1984VA06, 1985GO1A, 1986ER1A, 1987HO1L, 1987KI1C, 1987RA01, 1989AM01, 1989RA16, 1989SP01)

Astrophysical questions: (1982WO1A, 1986CO1R, 1986HA2D, 1987HA1E, 1987MA1X, 1987MA2C, 1988AP1A, 1988AP1B, 1988BE1B, 1989BO1M, 1989GU1L, 1989KA1K, 1989ME1C, 1989ST1D, 1989WH1B, 1990OE1C, 1990TH1C)

Applied work: (1985BA2G, 1985GO1R, 1986CI1B, 1986CS1B, 1986DO1M, 1986EF1A, 1986HO1L, 1986KI1J, 1986KO2A, 1986SR1B, 1986SU1H, 1987AR1N, 1987BA2M, 1987BA2N, 1987BO1U, 1987CU1E, 1987DU1G, 1987GA1E, 1987GO1W, 1987HE1F, 1987HE1G, 1987HO1J, 1987JA1G, 1987KII1, 1987KO1T, 1987KR1O, 1987KU1C, 1987LO1E, 1987MA2E, 1987NA1N, 1987NA1O, 1987OE1A, 1987OS1F, 1987PO1K, 1987RE1H, 1987SE1D, 1987SL1A, 1987TA1K, 1987VA1S, 1988DO1D, 1988EL1C, 1988JU1B, 1988PU1A, 1988SU1E, 1989LO14, 1989MU1A, 1990DO1C, 1990SA1J)

Complex reactions involving ¹⁴C: (1985AL28, 1985BA2G, 1985BE40, 1985BR1F, 1985HO21, 1985KA1E, 1985KA1G, 1985KAZQ, 1985KU24, 1985KW03, 1985PO12, 1985PO11, 1985PO14, 1985SI19, 1985VI01, 1986BA26, 1986BI1A, 1986CS1A, 1986DE32, 1986HA1B, 1986IR01, 1986ME06, 1986PA1N, 1986PI11, 1986PO06, 1986PO15, 1986PR1B, 1986SO10, 1986UT01, 1987BA38, 1987BL04, 1987BUZP, 1987BU07, 1987GU04, 1987HE1H, 1987IV01, 1987NA01, 1987PO1F, 1987PO1L, 1987PR1E, 1987RI03, 1987RU1C, 1987RU1D, 1987SH04, 1987SN01, 1987VI02, 1987YA16, 1988BA01, 1988BE56, 1988BL11, 1988CA06, 1988IV1C, 1988JO1B, 1988PR1B, 1988RU01, 1988SA19, 1988SA35, 1988SA1X, 1988SH29, 1989BA92, 1989BR34, 1989BU06, 1989BU05, 1989BU1H, 1989BU1I, 1989CI03, 1989CI1C, 1989FL1A, 1989GIZV, 1989GRZQ, 1989GU1B, 1989HO16, 1989KI13, 1989MA21, 1989MA43, 1989PO1I, 1989PO18, 1989PR02, 1989PR06, 1989PR1F, 1989SA1L, 1989SA10, 1989SA45, 1989SH37, 1989TE02, 1989YO02, 1990AR1E, 1990BU09, 1990BU13, 1990HU02, 1990OG01, 1990SH01, 1990WE01, 1990YA02)

Muon and neutrino capture and reactions (See also reaction 32 in (1986AJ01).): (1985KO39, 1989MU1G, 1990KO10)

Pion and kaon capture and reactions (See also reactions 15, 23, 31 and 32.): (1985AL15, 1985BA1A, 1985CH1G, 1985KO1Y, 1985TU1B, 1986BA1C, 1986BE1P, 1986BO1N, 1986CE04, 1986DY02, 1986ER1A, 1986FE1A, 1986FO06, 1986GE06, 1986GI06, 1986MA1C, 1986SI11,

1986SU18, 1986WU1D, 1987BA2F, 1987BL15, 1987DOZY, 1987GI1C, 1987JO1B, 1987KA39, 1987KO1Q, 1987MI02, 1987ROZY, 1988BA2D, 1988BA2R, 1988HA37, 1988KO1V, 1988LE1G, 1988MI1K, 1988OH04, 1988OS1A, 1988PA06, 1988RO1M, 1988TI06, 1988YU04, 1989CH31, 1989DI1B, 1989DO1K, 1989JO07, 1989LE11, 1989SI1B, 1989SI1D, 1990HAZV)

Hypernuclei: (1984ZH1B, 1986AN1R, 1986DA1B, 1986FE1A, 1986KO1A, 1986MA1C, 1986WU1D, 1987MI38, 1987PO1H, 1988MA1G, 1989BA92, 1989BA93, 1989DO1K, 1989GE10)

Other topics: (1985AN28, 1985MA56, 1986AN07, 1987AJ1A, 1988FL1A, 1989AJ1A, 1989DE1O, 1989PO05, 1990YA01)

Table 14.3: Energy Levels of ^{14}C ^a

E_x in ^{14}C (MeV \pm keV)	$J^\pi; T$	τ or $\Gamma_{\text{c.m.}}$	Decay	Reactions
g.s.	$0^+; 1$	$\tau_{1/2} = 5730 \pm 40$ y	β^-	1, 3, 4, 6, 7, 8, 9, 10, 11, 12, 15, 16, 17, 18, 19, 20, 21, 22, 23, 24, 25, 26, 27, 28, 30, 31, 32, 33, 34, 35, 36, 37, 38, 39
6.0938 ± 0.2 ^b	1^-	$\tau_m < 10$ fs	γ	3, 4, 6, 7, 8, 12, 15, 16, 18, 20, 22, 23, 26, 35, 38
6.5894 ± 0.2 ^b	0^+	4.3 ± 0.6 ps	γ	3, 4, 6, 8, 12, 16
6.7282 ± 1.3 ^b	3^-	96 ± 11 ps	γ	3, 4, 6, 7, 8, 9, 15, 16, 18, 20, 22, 23, 24, 26, 28, 35, 38
6.9026 ± 0.2 ^b	0^-	$ g = 0.272 \pm 0.007$ 36 ± 4 fs	γ	3, 4, 7, 8, 12, 16, 18, 22
7.0120 ± 4.2 ^b	2^+	13 ± 2 fs	γ	3, 4, 6, 7, 8, 15, 16, 18, 22, 23, 24, 26, 38, 39
7.3414 ± 3.1 ^b	2^-	160 ± 60 fs	γ	3, 4, 7, 8, 15, 16, 18, 20, 22, 26, 35, 38
8.3179 ± 0.8	2^+	$\Gamma = 3.4 \pm 0.7$ keV	γ, n	3, 4, 6, 7, 8, 9, 12, 13, 15, 16, 22, 23, 26, 32, 34, 35, 39
9.746 ± 7	0^+			8, 38

Table 14.3: Energy Levels of ^{14}C ^a (continued)

E_x in ^{14}C (MeV \pm keV)	$J^\pi; T$	τ or $\Gamma_{\text{c.m.}}$	Decay	Reactions
9.801 \pm 6	3 ⁻	45 \pm 12	γ, n	3, 6, 7, 8, 13, 15, 16, 22, 26, 38
10.425 \pm 5	2 ⁺		n	3, 6, 8, 13, 15, 16, 22, 26, 38
10.449 \pm 7	≥ 1		n	3, 6, 7, 8, 13, 15, 38
10.498 \pm 4	(3 ⁻)	26 \pm 8	n	3, 7, 8, 13, 15, 16, 23, 38
10.736 \pm 5	4 ⁺	20 \pm 7		3, 6, 7, 8, 9, 15, 16, 26, 32
11.306 \pm 15	1 ⁺	46 \pm 12	γ, n	3, 6, 13, 21, 22, 26, 38
11.395 \pm 8	1 ⁻	22 \pm 7	n	3, 6, 7, 8, 16, 26
(11.5)	1 ⁻ + 2 ⁻	broad	n	13
11.666 \pm 10	4 ⁻	20 \pm 7	γ	3, 6, 7, 8, 9, 15, 16, 22, 23, 24, 26, 38
11.730 \pm 9	(5 ⁻)			3, 6, 7, 8, 9, 15, 23
11.9 \pm 300	(1 ⁻)	950 \pm 300	n	13, 16
12.583 \pm 10	(2 ⁻ , 3 ⁻)	95 \pm 15	n	3, 7, 8, 13, 16, 23, 26, 38
12.863 \pm 8		30 \pm 10	n	3, 7, 8, 13, 16, 22
12.963 \pm 9	(3 ⁻)	30 \pm 10	n	3, 7, 8, 13, 16, 26
(13.50 \pm 100)		< 200		15
13.7	2 ⁻	\approx 1800	n	13
(14.05 \pm 100)		< 200		15
14.667 \pm 20	(4 ⁺)	57 \pm 15	n	3, 6, 7, 13
14.868 \pm 20	(6 ⁺ , 5 ⁻)			3, 6, 7, 8, 9, 15, 38
15.20 \pm 23	4 ⁻			3, 6, 7, 15, 22, 23
(15.37 \pm 30)				3
15.44 \pm 40	(3 ⁻)		n	3, 13
(16.02 \pm 50)	(4 ⁺)		n	3, 13
16.43 \pm 16				3, 6, 7, 8
(16.57 \pm 40)				3

Table 14.3: Energy Levels of ^{14}C ^a (continued)

E_x in ^{14}C (MeV \pm keV)	$J^\pi; T$	τ or $\Gamma_{\text{c.m.}}$	Decay	Reactions
16.715 \pm 30	(1 ⁺)	\approx 200	γ, n	3, 6, 12
17.30 \pm 30	4 ⁻		γ	3, 6, 7, 22, 23, 24
(17.5)	(1 ⁺)	\approx 200	γ, n	12
17.95 \pm 40				3
18.10 \pm 40				3
18.5		broad		15
20.4		wide		33
(21.4)				6
22.1 \pm 100	(2 ⁻ ; $T = 2$) ^c		γ	22
23.288 \pm 15 ^d		\approx 50		6, 15
24.4 \pm 100	4 ⁻ ; ($T = 2$)	< 300	γ	22, 23
24.5		wide		15, 23

^a See also Tables 14.4 here and in (1986AJ01), as well as Tables 14.8 and 14.9 and reaction 22.

^b See also reaction 16.

^c If this is the isobaric analog state of $^{14}\text{B}_{\text{g.s.}}$, then the $^{14}\text{B}-^{14}\text{C}$ Coulomb energy difference is calculated to be 2.25 ± 0.10 MeV (1989PL05).

^d See also reactions 6 and 15.

Figure 2: Energy levels of ^{14}C . In these diagrams, energy values are plotted vertically in MeV, based on the ground state as zero. Uncertain levels or transitions are indicated by dashed lines; levels which are known to be particularly broad are cross-hatched. Values of total angular momentum J , parity, and isobaric spin T which appear to be reasonably well established are indicated on the levels; less certain assignments are enclosed in parentheses. For reactions in which ^{14}C is the compound nucleus, some typical thin-target excitation functions are shown schematically, with the yield plotted horizontally and the bombarding energy vertically. Bombarding energies are indicated in laboratory coordinates and plotted to scale in cm coordinates. Excited states of the residual nuclei involved in these reactions have generally not been shown; where transitions to such excited states are known to occur, a brace is sometimes used to suggest reference to another diagram. For reactions in which the present nucleus occurs as a residual product, excitation functions have not been shown; a vertical arrow with a number indicating some bombarding energy, usually the highest, at which the reaction has been studied, is used instead. Further information on the levels illustrated, including a listing of the reactions in which each has been observed, is contained in the master table, entitled "Energy levels of ^{14}C ".

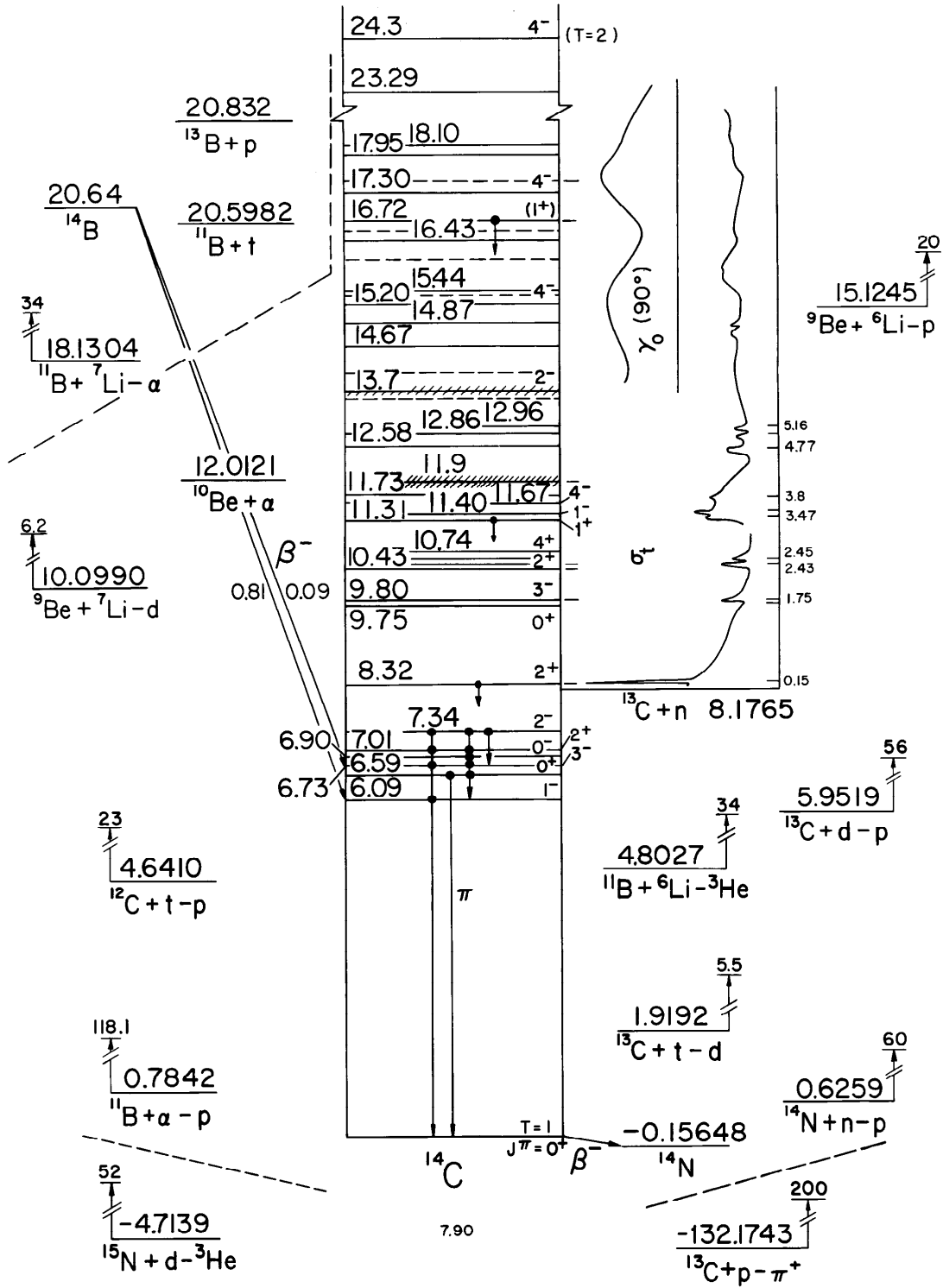

Ground state of ^{14}C : (1985AN28, 1985GO1A, 1985MI23, 1986HE26, 1987BL18, 1987KI1C, 1987SA15, 1987VA26, 1988VA03, 1988WO04, 1988WRZZ, 1989AN12, 1989GOZQ, 1989SA10, 1989TA01, 1989WO1E)

$$\langle r^2 \rangle^{1/2} = 2.4962(19) \text{ fm (1982SC11)}.$$

Adopted values from (1987RA01, 1989RA16):

$$B(E2) \uparrow (\text{to } ^{14}\text{C}^*(7.01)) = 0.00187(25) e^2 \cdot b^2,$$

$$Q_0 = 0.137(9) \text{ b}.$$

Table 14.4: Branching ratios of γ -rays in ^{14}C ^a

E_i (MeV)	J_i^π	E_f (MeV)	Branch (%)
6.09	1^-	0	100
6.59	0^+	0	1.1 ± 0.1 ^b
		6.09	98.9 ± 0.1 ^c
6.73	3^-	0	96.4 ± 1.2
		6.09	3.6 ± 1.2
6.90	0^-	6.09	100 ^d
7.01	2^+	0	98.6 ± 0.7
		6.09	1.4 ± 0.7
7.34	2^-	0	16.7 ± 3.5
		6.09	49.0 ± 3.1 ^{e, f}
		6.73	34.3 ± 3.5 ^e

^a For references see Table 14.5 in (1981AJ01). For the decay of $^{14}\text{C}^*$ (8.32) see reaction 12.

^b Internal pairs. $\Gamma_\pi/\Gamma = (1.1 \pm 0.1) \times 10^{-2}$, $\langle M \rangle_\pi = 0.36 \pm 0.06 \text{ fm}^2$.

^c $E_\gamma = 495.35 \pm 0.10 \text{ keV}$ (1981KO08).

^d $E_\gamma = 808.7 \pm 1.0 \text{ keV}$.

^e $\delta(M2/E1) = -0.04 \pm 0.09$ and $+0.07 \pm 0.30$, respectively.

^f $E_\gamma = 1248 \pm 3 \text{ keV}$.

1. $^{14}\text{C}(\beta^-)^{14}\text{N}$

$$Q_m = 0.15648$$

The adopted value of the half-life is 5730 ± 40 y: see (1976AJ04). Using Q_m , $\log ft=9.04$ (1971GO40). For discussions of the lifetime of ^{14}C see (1959AJ76, 1970AJ04, 1976AJ04). See also (1988YA10, 1988WRZZ, 1989DO1B, 1989PO1K, 1989SA1P, 1989WO1E; theor.). For the internal bremsstrahlung spectrum see (1988RA37).

Table 14.5: Levels of ^{14}C from $^9\text{Be}(^6\text{Li}, p)^{14}\text{C}$ ^a

E_x (MeV±keV)	$\Gamma_{\text{c.m.}}$ (keV)	$2J_f + 1$ ^b	J^π ^c
6.089 ± 10		2.5 [3]	
6.588 ± 10		1.0 [1]	
6.726 ± 10		7.6 [7]	
6.899 ± 10		1.1 [1]	
7.016 ± 10		4.5 [5]	
7.341 ± 10		5.2 [5]	
8.318 ± 10	22 ± 6	5.1	2 ⁺
9.796 ± 10	45 ± 12	7.7	3
10.441 ± 15		10.8	2 ⁺ + 3
10.512 ± 15	26 ± 8	9.1	4
10.743 ± 15	20 ± 7	15.4	
11.306 ± 15	46 ± 12	2.4	1 ⁻
11.397 ± 15	22 ± 7	6.2	2 ⁺ , 3
11.667 ± 15	20 ± 7	12.4	5 ⁻
11.74 ± 20			
12.57 ± 25	80 ± 20	15.1	
12.867 ± 20	30 ± 10	10.4	4, 5
12.970 ± 20	30 ± 10	7.8	3, 4
14.667 ± 20	57 ± 15		2 ⁺ , 3, 4, 5, 6 ⁺
14.867 ± 25			
15.19 ± 30			
(15.37 ± 30)			
15.44 ± 40			
(16.02 ± 50)			
16.411 ± 20			
(16.57 ± 40)			

Table 14.5: Levels of ^{14}C from $^9\text{Be}(^6\text{Li}, \text{p})^{14}\text{C}$ ^a (continued)

E_x	$\Gamma_{\text{c.m.}}$	$2J_f + 1$	J^π
16.715 ± 30 (17.28 ± 40)			
17.95 ± 40			
18.10 ± 40			

^a (1973AJ01): $E(^6\text{Li}) = 20$ MeV. See Table 14.6 in (1981AJ01) for additional information on cross sections and reduced widths.

^b The first number gives $2J_f + 1$, based on a best fit to the experimentally determined values for the cross section of the states with known spins. These $2J_f + 1$ values are determined to $\pm 10\%$, except for the last six values which are determined to $\pm 20\%$. The second number, in brackets, gives $2J_f + 1$ derived from the J_f assignments shown in Table 14.3.

^c Suggested from the $2J_f + 1$ rule and comparison of predicted neutron width with observed $\Gamma_{\text{c.m.}}$, assuming $0.01 < \theta_n^2 < 1.0$.

2. (a) $^7\text{Li}(^7\text{Li}, \text{n})^{13}\text{C}$	$Q_m = 18.618$	$E_b = 26.794$
(b) $^7\text{Li}(^7\text{Li}, \text{p})^{13}\text{B}$	$Q_m = 5.962$	
(c) $^7\text{Li}(^7\text{Li}, \text{d})^{12}\text{B}$	$Q_m = 3.309$	
(d) $^7\text{Li}(^7\text{Li}, \text{t})^{11}\text{B}$	$Q_m = 6.196$	
(e) $^7\text{Li}(^7\text{Li}, \alpha)^{10}\text{Be}$	$Q_m = 14.782$	
(f) $^7\text{Li}(^7\text{Li}, ^7\text{Li})^7\text{Li}$		

For $E(^7\text{Li}) = 2.3$ to 5.8 MeV, the cross section for emission of α_0 , α_1 and α_{2+3+4} is found to increase monotonically with energy. There is a report of several broad structures in the 0° yield of α_0 and α_1 for $E(^7\text{Li}) = 2$ to 20 MeV: it is suggested that they are due to a forward-direction cluster transfer process: see (1976AJ04) for references. For other work see (1970AJ04, 1986AJ01). For reaction (a) see also (1987SC11).

3. $^9\text{Be}(^6\text{Li}, \text{p})^{14}\text{C}$	$Q_m = 15.1245$
--	-----------------

Observed proton groups are displayed in Table 14.5. See also ^{15}N .

4. ${}^9\text{Be}({}^7\text{Li}, \text{d}){}^{14}\text{C}$ $Q_m = 10.0990$

Angular distributions have been measured at $E({}^7\text{Li}) = 5.6$ to 6.2 MeV for the deuterons to ${}^{14}\text{C}^*(0, 6.09, 6.59 + 6.73, 6.90 + 7.01, 7.34, 8.32)$. Gamma rays with $E_\gamma = 6094.5 \pm 3.2, 6728.1 \pm 1.4$ and 7011.7 ± 5.2 keV have been reported: see (1981AJ01) for references. For τ_m and E_γ measurements see Tables 14.4 in (1986AJ01) and 14.4 here (1981KO08) [see this reference for an extensive study of electromagnetic transitions in ${}^{14}\text{C}$ and ${}^{14}\text{N}$].

5. (a) ${}^{11}\text{B}(\text{t}, \text{n}){}^{13}\text{C}$ $Q_m = 12.4217$ $E_b = 20.5982$

(b) ${}^{11}\text{B}(\text{t}, \alpha){}^{10}\text{Be}$ $Q_m = 8.5861$

For possible resonant structure in (a) see (1976AJ04). For reaction (b) see (1981AJ01, 1986AJ01). See also (1990HA46).

6. ${}^{11}\text{B}(\alpha, \text{p}){}^{14}\text{C}$ $Q_m = 0.7842$

Angular distributions of p_0 have been measured at $E_\alpha = 1.43$ to 31.2 MeV: see (1976AJ04, 1981AJ01, 1986AJ01). At $E_\alpha = 118.1$ MeV angular distributions have been studied [DWBA analysis] to ${}^{14}\text{C}^*(6.09, 6.59, 6.73, 7.01, 8.32, 9.80, 10.43[\text{u}], 10.74, 11.38[\text{u}], 11.7[\text{u}], 14.67, 14.87, 15.20, 16.43, 16.72, 17.30, 21.40 [\text{u}?])$. It is suggested that one of the states at 11.7 MeV has $J^\pi = 4^-$ and the other $J^\pi = (1, 2, 3)^-$, and that the state at 16.43 has $J^\pi = 6^-$ (1987AN04). At $E_\alpha = 48$ MeV an angular distribution is reported to a state at $E_x = 23.288 \pm 0.015$ MeV with $\Gamma_{\text{lab}} = 70 \pm 3$ keV. The sharpness of the state suggests that J is large, and that perhaps it is a 7^- state (1988BR26, and J.D. Brown, private communication). A search has been made for an 8^- state up to 26 MeV (at 20°): the upper limit for its strength is 0.2 that for the 23.29 MeV state (J.D. Brown, private communication). See also ${}^{15}\text{N}$, (1989BR1J) and (1988CA26; astrophys.).

7. (a) ${}^{11}\text{B}({}^6\text{Li}, {}^3\text{He}){}^{14}\text{C}$ $Q_m = 4.8027$

(b) ${}^{11}\text{B}({}^7\text{Li}, \alpha){}^{14}\text{C}$ $Q_m = 18.1304$

Below $E_x = 10.4$ MeV, ${}^{14}\text{C}^*(6.09, 6.73, 6.90 + 7.01, 7.34, 8.32, 9.78)$ are observed in both reactions at $E(\text{Li}) = 34$ MeV (1984CL08): the states observed at higher excitation energies are displayed in Table 14.6. The intensities of the ${}^3\text{He}$ and α groups in the two reactions are significantly different. Comparison of the angular distributions in reaction (a) and in the analog reaction ${}^{11}\text{B}({}^6\text{Li}, \text{t}){}^{14}\text{N}$, as well as other data, leads to the assignment of analog pairs: see reaction 11 in ${}^{14}\text{N}$. It is suggested that ${}^{14}\text{C}^*(11.73)$ and not ${}^{14}\text{C}^*(11.67)$ is populated in the inelastic pion scattering (1984CL08). For the earlier work on reaction (b), see (1976AJ04).

Table 14.6: States in ^{14}C from $^{11}\text{B}(^6\text{Li}, ^3\text{He})$ and $^{11}\text{B}(^7\text{Li}, \alpha)$ ^a

E_x (MeV \pm keV) ^b	E_x (MeV \pm keV) ^b
10.47 ± 15 ^c	12.96 ± 30
10.74 ± 15 ^d	14.67 ± 30
11.40 ± 20 ^e	14.87 ± 30
11.66 ± 15	15.21 ± 30
11.73 ± 15	16.45 ± 25 ^e
12.58 ± 30	17.32 ± 40
12.86 ± 30	

^a (1984CL08): $E(\text{Li}) = 34$ MeV. See for angular distributions and for discussion of analog states in ^{14}N . See also reaction 11 in ^{14}N .

^b States below $E_x = 10.4$ MeV are not displayed here.

^c Unresolved.

^d Differential cross section at 10° in $^{11}\text{B}(^6\text{Li}, ^3\text{He})$ is much higher than in $^{11}\text{B}(^7\text{Li}, \alpha)$.

^e More strongly populated in $^{11}\text{B}(^7\text{Li}, \alpha)$.

8. $^{12}\text{C}(t, p)^{14}\text{C}$ $Q_m = 4.6410$

Observed proton groups are displayed in Table 14.7. Angular distributions have been measured at $E_t = 5.5$ to 23 MeV [see (1981AJ01)] and at 33 MeV (1986COZO; prelim.; to $^{14}\text{C}^*(6.09, 6.6[\text{u}], 7.01, 8.31, 10.5[\text{u}], 14.87, 16.43)$. For other results see (1986AJ01). See also ^{15}N .

9. $^{12}\text{C}(\alpha, 2p)^{14}\text{C}$ $Q_m = -15.1731$

At $E_\alpha = 65$ MeV angular distributions have been measured to $^{14}\text{C}^*(0, 6.73 \pm 0.02, 8.40 \pm 0.14, 10.69 \pm 0.05, 11.69 \pm 0.06[\text{u}], 14.84 \pm 0.4)$. The two most strongly populated states (or groups of states) are $^{14}\text{C}^*(6.73, 10.69)$. $J^\pi = 1^-$ and $(6^+, 5^-)$ are favored for $^{14}\text{C}^*(11.69, 14.84)$. For the latter 4^+ is considered to be very unlikely: see (1986AJ01). See also (1981AJ01) for the earlier work.

10. $^{12}\text{C}(^{14}\text{N}, ^{12}\text{N})^{14}\text{C}$ $Q_m = -17.495$

See (1986BA16, 1986EL1C, 1986RO1Q).

Table 14.7: ^{14}C states from $^{12}\text{C}(t, p)^{14}\text{C}$ ^a

E_x ^b (MeV \pm keV)	E_x ^c (MeV \pm keV)	L ^{b,c}	J^π
-0.006 ± 10	0	0	0^+
6.087 ± 10	6.099 ± 10	1	1^-
6.577 ± 10	6.589 ± 10	0	0^+
6.725 ± 10	6.731 ± 10	3	3^-
6.895 ± 10	6.899 ± 10	weak	
$\equiv 7.012$	7.017 ± 10	2	2^+
7.336 ± 10	7.342 ± 10	weak	
8.307 ± 12	8.315 ± 10	2	2^+
9.746 ± 7 ^d		0	0^+
9.809 ± 10 ^d	9.80 ± 20 ^e	(1)	(1^-)
10.425 ± 6 ^d	10.419 ± 20	2	2^+
10.448 ± 10			
10.498 ± 4 ^d	10.492 ± 20	(3)	(3^-) ^f
10.736 ± 5 ^d	10.730 ± 20	4	4^+
11.398 ± 10	11.377 ± 20	1	1^-
11.665 ± 13	11.647 ± 30	(1)	(1^-)
11.727 ± 10	^e	(5)	(5^-)
12.580 ± 12		(2, 3)	($2^+, 3^+$)
12.867 ± 10	12.849 ± 20	2, 3	$2^+, 3^-$
12.963 ± 10	12.945 ± 30	(1)	(1^-)

^a See also Tables 14.5 in (1976AJ04) and 14.7 in (1981AJ01), and (1982FO01), and reaction 8.

^b $E_t = 18$ MeV (1978MO07, 1978MO08).

^c $E_t = 23$ MeV (1978AJ02).

^d The widths for $^{14}\text{C}^*$ (9.75, 9.81, 10.43, 10.50, 10.74) are, respectively 18, 40, 14, 18 and 15 keV (1978MO07, 1978MO08).

^e Very weak at all angles.

^f See also the note added in proof on p. 476 of (1978MO08).

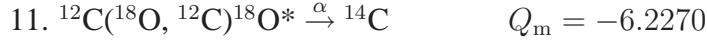

See ^{18}O in (1987AJ02).

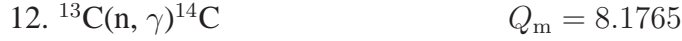

The thermal capture cross section is 1.37 ± 0.04 mb (1982MU14). The decay is primarily to $^{14}\text{C}^*(0, 6.59)$ [(84.0 \pm 2.3)%, (8.5 \pm 0.5)%, (8.5 \pm 0.5)%] with weaker branches to $^{14}\text{C}^*(6.09, 6.90)$ [(2.5 \pm 0.5)%, (4.9 \pm 1)%]. Gamma rays with $E_\gamma = 8173.92, 6092.4 \pm 0.2, 2082.6 \pm 0.3, 1586.8 \pm 0.2, 1273.9 \pm 0.2, 808.9 \pm 0.2$ and 495.4 ± 0.3 keV have been observed: $E_x = 6093.8 \pm 0.2, 6589.4 \pm 0.2$ and 6902.6 ± 0.2 keV are reported for $^{14}\text{C}^*(6.09, 6.59, 6.90)$. The neutron capture yield for $E_n = 95$ to 235 keV shows a resonance at $E_n = 152 \pm 1$ keV, $\Gamma_{\text{lab}} = 5 \pm 1$ keV: see Table 14.8 in (1981AJ01). A revised value of Γ_γ is 2.4 ± 0.9 eV [see R.L. Macklin quoted in (1990RA03)]. A recent remeasurement of the on- and off-resonance capture determines the following Γ_γ (in meV) for the listed transitions: $8.32 \rightarrow \text{g.s.} = 34_{-6}^{+13}$; $8.32 \rightarrow 6.09 = 151_{-33}^{+76}$; $8.32 \rightarrow 6.73 = 30_{-13}^{+30}$. Thus the total radiation width for $^{14}\text{C}^*(8.32)$ is 215_{-35}^{+84} meV. The off-resonance capture cross section is 20 ± 9 μb (1990RA03). The decrease by an order of magnitude in the Γ_γ of $^{14}\text{C}^*(8.32)$ has an important bearing on nucleosynthesis and appears to significantly reduce the production of $A \geq 14$ nuclei in the non-standard Big Bang (1990RA03).

Angular distributions of cross sections and A_y and the $90^\circ\gamma_0$ cross sections have been measured in the range $E_n = 5.6$ to 17 MeV. M1 resonances are indicated at $E_n \approx 9.2$ and 10.1 MeV ($\Gamma \approx 200$ keV) [$E_x = 16.7$ and 17.5 MeV]. $\sigma(\text{E}2)$ is less than 2% of the total capture cross section for $E_n = 5.6$ to 17 MeV (1985WR01). See also (1988MA1U, 1989DE28; astrophysics) and (1985WE06, 1986HO1N, 1987LY01, 1988HO06, 1988HO1E, 1988RA10; theor.).

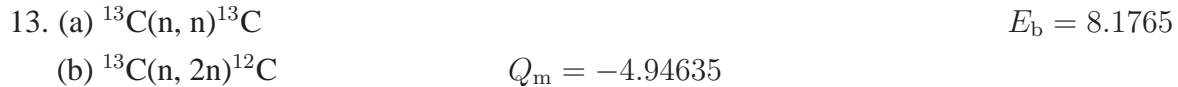

The coherent scattering length (thermal, bound) is 6.19 ± 0.09 fm, $\sigma_{\text{scatt}} = 4.16 \pm 0.13$ b (1979KO26) [see, however, (1986AJ01)]. $a_{j=1} = 5.5 \pm 0.1$ fm; $a_{j=0} = 6.6 \pm 0.4$ fm: see (1987LY01). The total cross section has been measured from 0.1 to 23 MeV: see (1988MCZT, 1981AJ01).

The results of an R -matrix analysis based on $\sigma(\theta)$ for neutrons scattered to $^{13}\text{C}^*(0, 3.09, 3.68, 3.85)$ for $4.5 \leq E_n \leq 11$ MeV and on some other work are shown in Table 14.8 (1989RE01).

The cross section for reaction (b) has been studied for $E_n = 7.5$ to 14.8 MeV: see unpublished work quoted in (1987RE01). Double differential cross sections have been studied at $4.55 \leq E_n \leq 10.99$ MeV: evidence is found for the excitation of ^{14}C states [$E_x = 15.8 - 18.4$ MeV] which decay to $^{12}\text{C}_{\text{g.s.}}$ via $^{13}\text{C}^*(7.55)$ [$J^\pi = \frac{5}{2}^-$] (1987RE01).

Table 14.8: R -matrix analysis of $^{13}\text{C}(n, n)$ ^a

E_n (keV)	E_x (MeV)	$\Gamma_{\text{c.m.}}$ (keV)	J^π
152.9 ± 1.4	8.3184 ± 0.9	3.4 ± 0.7	
1736	9.79	14	3^-
1754	9.8	38	1^-
2426	10.43	9	$3^{(-)}$
2445	10.45	7	$(1^+, 2)$
2504	10.50	$\ll 5$	≥ 1
3358	11.292	170	1^+
3500	11.4	2700	1^-
3700	11.6	1300	2^-
4330	12.19	370	1^-
4770	12.60	180	2^-
5050 ^b	12.86		
5162 ^b	12.97		
6000	13.7	1800	2^-
6950	14.62	390	(1^-)
7048	14.716	90	4^+
7260	14.91	250	(1^+)
7950	15.55	270	3^-
8300	15.9	630	(1^-)
8340	15.91	330	4^+
9100	16.6	780	(1^+)
10200	17.6	1300	(1^+)

^a For the 153 keV resonance see Table 14.8 in (1981AJ01); for the structures at $E_n < 3$ MeV see (1981AJ01) and (1981LA05) [quoted in Table 14.9 of (1986AJ01)]; for higher energy structures see (1989RE01).

^b See Table 14.9 in (1986AJ01).

14. (a) $^{13}\text{C}(\text{n}, \text{p})^{13}\text{B}$	$Q_{\text{m}} = -12.655$	$E_{\text{b}} = 8.1765$
(b) $^{13}\text{C}(\text{n}, \text{t})^{11}\text{B}$	$Q_{\text{m}} = -12.4217$	
(c) $^{13}\text{C}(\text{n}, \alpha)^{10}\text{Be}$	$Q_{\text{m}} = -3.8356$	

For reaction (a) see ^{13}B and (1989SOZY). For reaction (b) see (1988MCZT). For reaction (c) see (1989RE01).

15. $^{13}\text{C}(\text{p}, \pi^+)^{14}\text{C}$	$Q_{\text{m}} = -132.1743$
---	----------------------------

At $E_{\text{p}} = 185$ and 200 MeV the angular distributions of π^+ and π^- to the ground states of ^{14}C and ^{14}O are very different: see (1986AJ01). Angular distributions and A_{y} measurements have been reported at $E_{\text{p}} = 200$ MeV by (1987KO01, 1989KO21) to $^{14}\text{C}^*(0, 6.09, 6.9[\text{u}], 7.34, 8.32, 9.8[\text{u}], 10.4[\text{u}], 10.7[\text{u}], 11.7[\text{u}], (13.0, 13.6), 14.87[\text{u}], 18.5 [\text{broad}], 23.2)$. The latter state has an energy of 23.2 ± 0.1 MeV and $\Gamma \lesssim 85$ keV: it is not clear whether this is the same state as that reported in the $^{11}\text{B}(\alpha, \text{p})^{14}\text{C}$ reaction at 23.29 MeV (Dr. S. Vigdor, private communication). $A_{\text{y}} \approx 0$ at all angles for this state (1987KO01, 1989KO21). Assuming that the π^{\pm} groups to $^{14}\text{C}^*(6.9)$ and $^{14}\text{O}^*(6.3)$ correspond to single states, and that the first populates $^{14}\text{C}^*(6.73) [J^{\pi} = 3^-]$, then $^{14}\text{O}^*(6.27)$ is assigned $J^{\pi} = 3^-$ also. A similar comparison of $^{14}\text{C}^*(14.87)$ with $^{14}\text{O}^*(14.15)$, and with $^{14}\text{N}^*(16.91) [J^{\pi} = 5^-; 1]$ suggests $J^{\pi} = 5^-$ for these ^{14}C and ^{14}O states (1989KO21). (1988HU04) report differential cross sections at $E_{\text{p}} = 250, 354$ and 489 MeV to $^{14}\text{C}^*(0, 6.09, 6.7[\text{u}], 7.34, 8.32, 9.80[\text{u}], 10.5[\text{u}], 11.7[\text{u}], 14.87, 23.2)$ and to previously unreported states at $E_{\text{x}} = 13.50$ and 14.05 MeV: The (p, π^+) reactions show an enhancement of the $\sigma(\theta)$ near the invariant mass of the Δ_{1232} , in contrast with the (p, π^-) reactions. A broad structure near $E_{\text{x}} = 25$ MeV is also observed (1988HU06) [see also for a continuum study]. (R.D. Bent and G.M. Huber, private communication) report that, from their measurements, $E_{\text{x}} = 23.2 \pm 0.6$ MeV and $\Gamma_{\text{c.m.}} < 200$ keV. The assignment of $J^{\pi} = 5^-$ to $^{14}\text{N}^*(14.87)$ [see fig. 2 of (1988HU04)] is tentative. The uncertainties in the $E_{\text{x}} = 13.50$ and 14.05 MeV states are ± 100 keV and their $\Gamma_{\text{c.m.}}$ are < 200 keV. I am greatly indebted to Drs. Bent and Huber for their comments. See also reactions 5 in ^{14}O , (1986JA1H, 1988HU11) and (1987KU06; theor.).

16. (a) $^{13}\text{C}(\text{d}, \text{p})^{14}\text{C}$	$Q_{\text{m}} = 5.9519$
(b) $^{13}\text{C}(\text{t}, \text{d})^{14}\text{C}$	$Q_{\text{m}} = 1.9192$

Observed proton groups are displayed in Table 14.10 of (1986AJ01). Recent measurements of proton groups, using a spectrograph, give $E_{\text{x}} = 6094.05 \pm 0.11, 6589.58 \pm 0.39, 6731.58 \pm 0.11, 6902.24 \pm 0.18, 7011.4 \pm 0.8$ and 7342.65 ± 0.32 keV (1990PI05). Angular distributions have been measured at a number of deuteron energies up to 17.7 MeV: see (1981AJ01, 1986AJ01).

Gamma rays are exhibited in Table 14.4: studies of these, of the angular distributions analyzed by DWBA, and of $p\gamma$ correlations lead to the following J^π assignments [see reaction 14 in (1970AJ04) for a full discussion of the evidence and a listing of the relevant references]. $^{14}\text{C}^*(6.09)$ is 1^- (decay is E1); $^{14}\text{C}^*(6.59)$ is 0^+ (internal pairs only); $^{14}\text{C}^*(6.73)$ is 3^- (γ_0 is E3; $l_n = 2$); $^{14}\text{C}^*(6.90)$ is 0^- (no γ_0 ; 0.81 MeV cascade via 6.09 is predominantly dipole; $\gamma_{0.8} + \gamma_{6.1}$ correlation is only consistent with $J = 0$, and plane polarization leads to negative parity); $^{14}\text{C}^*(7.34)$ is 2^- (strength of cascade decay and angular correlation results). For a study of the pair decay of $^{14}\text{C}^*(6.90)$ [$J^\pi = 0^-$] see (1986PA23). See also ^{15}N , (1987AB04) and (1985ME1E; applied).

In reaction (b) at $E_t = 38$ MeV angular distributions have been studied to $^{14}\text{C}^*(0, 6.09, 6.6[\text{u}], 7.0[\text{u}], 7.34, 8.32, 9.8, 10.4[\text{u}])$ (1988SI08).

$$17. \ ^{13}\text{C}(^6\text{Li}, ^5\text{Li})^{14}\text{C} \quad Q_m = 2.51$$

(1988WO10) [and see ^5He , reaction 9 in (1988AJ01)].

$$18. \ ^{13}\text{C}(^7\text{Li}, ^6\text{Li})^{14}\text{C} \quad Q_m = 0.926$$

At $E(^7\text{Li}) = 34$ MeV angular distributions have been studied to $^{14}\text{C}^*(0, 6.09, 6.73, 7.34)$: $S = 1.70, 0.43, 0.59, 0.55$ (1987CO16). See also (1986AJ01).

$$19. \ ^{13}\text{C}(^{13}\text{C}, ^{12}\text{C})^{14}\text{C} \quad Q_m = 3.2302$$

See (1986AJ01). See also (1987GR1K) and (1987TH04; theor.).

$$20. \ ^{14}\text{B}(\beta^-)^{14}\text{C} \quad Q_m = 20.64$$

^{14}B decays primarily to $^{14}\text{C}^*(6.09, 6.73)$: see Table 14.2. The half-life is 13.8 ± 1.0 ms: see ^{14}B .

$$\begin{aligned} 21. \text{ (a) } & \ ^{14}\text{C}(\gamma, \text{n})^{13}\text{C} & Q_m = -8.1765 \\ & \text{ (b) } & \ ^{14}\text{C}(\gamma, 2\text{n})^{12}\text{C} & Q_m = -13.1229 \\ & \text{ (c) } & \ ^{14}\text{C}(\gamma, \text{p})^{13}\text{B} & Q_m = -20.832 \end{aligned}$$

The cross sections for reactions (a) and (b) have been measured with monochromatic photons to $E_\gamma = 36$ MeV (and the (γ, Tn) cross section has been derived) by (1985PY01). A sharp state is observed [with $\sigma \approx 3$ mb] at $E_x = 11.25 \pm 0.05$ MeV (1985PY01) [also observed in the (γ, n_0) work of (1985KU01) and showing a pronounced E1-M1 interference], sitting on a 1 mb tail of the GDR. The integrated value of the cross section is 1.1 ± 0.1 MeV \cdot mb, yielding $\Gamma_{\gamma 0} = 12 \pm 1$ eV. Most of the M1 strength of the ^{12}C core is concentrated at 11.3 MeV (1985PY01). While other states on ^{14}C affect the (γ, n) cross section at higher energies there is no evidence of pigmy resonances. The next major peak is at 15.5 MeV ($\sigma \approx 9.1$ mb), whose decay is by neutrons to $^{12}\text{C}_{\text{g.s.}}$. Above 17.5 MeV the neutron decay becomes more complex (1985PY01). Reaction (b) has little strength below 23.3 MeV. Above that energy, states of ^{14}C (T_{\geq}) can decay to $^{13}\text{C}^*(15.1)$ [$T = \frac{3}{2}$], which subsequently decays by neutron emission (1985PY01). See also the (γ, n_0) work of (1985KU01), (1988DI02) and (1985GO1A, 1987GO09, 1987KI1C; theor.).

22. $^{14}\text{C}(e, e)^{14}\text{C}$

The charge radius of ^{14}C , $r_{\text{r.m.s.}} = 2.56 \pm 0.05$ fm (1973KL12). At $E_e = 37 - 60$ MeV ($\theta = 180^\circ$) inelastic groups are reported to $^{14}\text{C}^*(7.01, 7.34, 8.32, 9.80, 10.5, 11.31 \pm 0.02, 12.96, 14.67)$ with the 11.3 MeV state [1^+ , $\Gamma = 207 \pm 13$ keV, $\Gamma_{\gamma 0} = 6.8 \pm 1.4$ eV] dominant (1977CR02). At $E_e = 81.9$ to 268.9 MeV ($\theta = 180^\circ$) (1989PL05, 1984PL02) find the dominant strength to be to 4 states at 11.7, 17.3 and 24.4 MeV [± 0.1 MeV]. The first two of these are $T = 1$ states reported in the (π, π) reaction below, the third is suggested to have $T = 2$ (and to be unresolved from a 2^- state). The M4 form factors account for 41% and 37% of the $T = 1$ and $T = 2$ single-particle (e, e') cross section, respectively. The observed transitions to the $T = 1$ states exhaust 33–45% of the total isovector transition strength and 1–15% of the isoscalar transition strength. Magnetic electron scattering is most sensitive to isovector transitions (1984PL02). The population of $^{14}\text{C}^*(6.1, 6.7, 7.0, 8.3, 9.84 \pm 0.05, 10.50 \pm 0.05, 12.2 \pm 0.1, 12.9 \pm 0.1, 13.6 \pm 0.1, 14.0 \pm 0.1, 14.9 \pm 0.1, 15.2 \pm 0.1, 16.5 \pm 0.1, 22.1 \pm 0.1)$ is also reported (1989PL05, 1984PL02). See also (1987DE43, 1986HI06, 1989AJ1A) and (1986LI1C, 1987GO08, 1987KI1C, 1987LI30, 1988CL03, 1988HO1E, 1990CL02, 1990GA1M; theor.).

23. $^{14}\text{C}(\pi^\pm, \pi^\pm)^{14}\text{C}$

Elastic angular distributions have been measured at $E_{\pi^\pm} = 50$ MeV (1985MI16), 65 and 80 MeV (1983BL11) and 164 MeV (1986HA2E). At $E_{\pi^\pm} = 164$ MeV, the differential cross sections for the transition to $^{14}\text{C}^*(7.01)$ [$J^\pi = 2_1^+$] are nearly the same for π^+ and π^- . Angular distributions have also been studied to the 2_2^+ state, $^{14}\text{C}^*(8.32)$, and to an unresolved group at $E_x = 10.4$ MeV [the latter results are consistent with $J^\pi = 3^-$ distribution] (1988HA14) [see for discussion of $B(E2)$]. In earlier work at $E_{\pi^\pm} = 164$ MeV angular distributions had been obtained to states at $E_x = 6.7, 11.7, 15.2, 17.3$ MeV [± 0.1 MeV] with $J^\pi = 3^-, 4^-, 4^-, 4^-$. In addition a broad

structure ($\Gamma \approx 1.7$ MeV) had been observed near 24.5 MeV. It may include a narrower peak at 24.4 MeV (1985HO07): see also the Erratum (1990HO1C). The population of $^{14}\text{C}^*(6.1, 12.6)$ has also been reported: see (1986AJ01). See also (1989AJ1A).

24. (a) $^{14}\text{C}(p, p)^{14}\text{C}$
(b) $^{14}\text{C}(d, d)^{14}\text{C}$

At $E_p = 497$ MeV $^{14}\text{C}^*(11.7, 17.3)$ [$J^\pi = 4^-$] are populated (1989CRZX; prelim.). Elastic angular distributions are reported at $E_p = 35$ and 40.1 MeV (1990YA01). See also (1981AJ01, 1986AJ01) [the work quoted in (1986AJ01) has not been published.]

25. $^{14}\text{C}(^3\text{He}, ^3\text{He})^{14}\text{C}$

Elastic angular distributions have been studied at $E(^3\text{He}) = 4.5$ to 18 MeV [see (1976AJ04)], at 22 MeV (1988AD1B; prelim.) and 72 MeV (1988DE34, 1989ER05) and at 39.6 MeV (1987BUZR; prelim.). See also (1989DE1Q, 1989GA1I) and (1986ZE04; theor.).

26. $^{14}\text{C}(\alpha, \alpha)^{14}\text{C}$

Elastic angular distributions have been studied at $E_\alpha = 22, 24$ and 28 MeV [see (1976AJ04)] and at $E_\alpha = 35.5$ MeV (1984PE24). At the latter energy many inelastic groups have also been studied: see Table 14.9 (1984PE24). See also ^{18}O in (1987AJ02) and (1985UM01; theor.).

27. $^{14}\text{C}(^6\text{Li}, ^6\text{Li})^{14}\text{C}$

Elastic angular distributions have been obtained at $E(^6\text{Li}) = 93$ MeV (1986BR33, 1987DE02, 1988DE47, 1989DE34) and 210 MeV (1987WI09; forward angles).

28. (a) $^{14}\text{C}(^{12}\text{C}, ^{12}\text{C})^{14}\text{C}$
(b) $^{14}\text{C}(^{13}\text{C}, ^{13}\text{C})^{14}\text{C}$
(c) $^{14}\text{C}(^{14}\text{C}, ^{14}\text{C})^{14}\text{C}$

The elastic scattering for reaction (a) has been studied at $E(^{14}\text{C}) = 20$ to 40.3 MeV (1986STZY; prelim.) and 31 to 56 MeV (1985KO04); that for reaction (b) has been studied at $E(^{13}\text{C}) = 20$ to 27.5 MeV (1988BI11) [see also reaction 50 in ^{13}C]; and that for reaction (c) is reported at $E(^{14}\text{C}) = 31$ to 56 MeV: see (1986AJ01). For the earlier work see (1976AJ04). For yield and fusion studies see (1986AJ01) and (1986STZY). The yields of γ -rays from $^{14}\text{C}^*(6.73)$ [$J^\pi = 3^-$] have been measured for $E(^{14}\text{C}) = 25$ to 70 MeV: see (1986AJ01). See also (1990VO1E) and (1986BA69; theor.).

29. $^{14}\text{C}(^{15}\text{N}, ^{15}\text{N})^{14}\text{C}$

See (1986BA69; theor.).

30. (a) $^{14}\text{C}(^{16}\text{O}, ^{16}\text{O})^{14}\text{C}$

(b) $^{14}\text{C}(^{17}\text{O}, ^{17}\text{O})^{14}\text{C}$

(c) $^{14}\text{C}(^{18}\text{O}, ^{18}\text{O})^{14}\text{C}$

The elastic scattering has been studied in reaction (a) at $E(^{16}\text{O}) = 20, 25$ and 30 MeV [see (1981AJ01)] and at $E(^{14}\text{C}) = 20$ to 43 MeV (1986STZY; prelim.); that for reaction (c) has been studied for $E(^{14}\text{C}) = 20$ to 30 MeV (1986STZY). The α -breakup in reaction (c) is being investigated at $E(^{18}\text{O}) = 33.5$ to 64 MeV (1988AL1F; prelim.). For excitation functions see (1986AJ04) and (1986STZY). See also (1989CI1C) and (1986BA69; theor.).

31. $^{14}\text{N}(\gamma, \pi^+)^{14}\text{C}$

$$Q_m = -139.725$$

Differential cross sections to $^{14}\text{C}_{\text{g.s.}}$ have been measured at $E_\gamma = 173$ MeV (1985RO05, 1987RO23), at 200 MeV (1985CO15), at 230, 260 MeV and 320 MeV (1986TE01, 1990GH01) and at 320 and 400 MeV (1990DI1D; prelim.). The transitions to the 2^+ states at 7.01+8.32[u] and 10.7 MeV have been studied by (1987SU17) [see for $B(M1)$]. See also (1985BE1K, 1987HU01, 1987YA1J), (1986WI10, 1988TI06, 1990ER03; theor.) and the “General” section.

32. $^{14}\text{N}(\pi^-, \gamma)^{14}\text{C}$

$$Q_m = 139.412$$

The photon spectrum from stopped pions is dominated by peaks corresponding to $^{14}\text{C}^*(6.7 + 6.9 + 7.0[\text{u}], 8.32, 10.7)$ and branching ratios have been obtained for these and the g.s. transition. That to $^{14}\text{C}^*(6.7 + 6.9 + 7.0)$ is $(6.22 \pm 0.40)\%$ (absolute branching ratio per stopped pion) (1986PE05). For the earlier work see (1981AJ01). See also the “General” section.

33. $^{14}\text{N}(n, p)^{14}\text{C}$ $Q_m = 0.6259$

The p_0 angular distribution has been measured at $E_n = 14$ MeV: see (1981AJ01). At $E_n = 60$ MeV the strongest transitions are to $^{14}\text{C}^*(7.0 + 8.3, 11.3, 15.4)$ and to the giant resonance peak, centered at ≈ 20.4 MeV, and angular distributions have been studied to these groups: see (1986AJ01). For cross sections of astrophysical interest see ^{15}N . A study of P-odd and left-right asymmetries with polarized thermal neutrons is reported by (1988AN19). See also (1986BO1K, 1988EL1C; applied).

34. $^{14}\text{N}(d, 2p)^{14}\text{C}$ $Q_m = -1.5987$

Angular distributions have been measured at $E_d = 70$ MeV to $^{14}\text{C}^*(7.0[u], 8.3)$. The ground state is very weakly populated (1986MO27). See also (1988HE11).

35. $^{14}\text{N}(t, ^3\text{He})^{14}\text{C}$ $Q_m = -0.13788$

At $E_t = 33.4$ MeV $^{14}\text{C}^*(0, 6.09, 6.73, 7.34, 8.32)$ are populated (1988CL04).

36. $^{14}\text{N}(^7\text{Li}, ^7\text{Be})^{14}\text{C}$ $Q_m = -1.018$

See (1986GO1B; prelim.; $E(^{14}\text{N}) = 150$ MeV).

37. $^{15}\text{N}(\gamma, p)^{14}\text{C}$ $Q_m = -10.2074$

See (1981AJ01), ^{15}N and (1988GOZM; theor.).

38. $^{15}\text{N}(d, ^3\text{He})^{14}\text{C}$ $Q_m = -4.7139$

The parameters of ^{14}C states observed in this reaction are displayed in Table 14.9 of (1976AJ04).

39. $^{16}\text{O}(^6\text{Li}, ^8\text{B})^{14}\text{C}$ $Q_m = -16.592$

At $E(^6\text{Li}) = 93$ MeV $^{14}\text{C}^*(0, 7.01, 8.32, 10.45)$ are populated, the first two of these strongly: see (1981AJ01).

Table 14.9: States of ^{14}C from $^{14}\text{C}(\alpha, \alpha')$ ^a

E_x (MeV) ^b	L ^c	J^π	β^2 ^d
6.09	1	1^-	0.050
6.73	3	3^-	0.158
7.01 ^e	2	2^+	0.086
7.34		2^-	
8.32 ^e	2	2^+	0.049
9.80	3	3^-	0.068
10.44 ± 0.06 ^e	2	2^+	0.038
10.74	4	4^+	0.018
11.32 ± 0.06	2	2^+	0.014
11.62 ± 0.08		4^-	
12.58	3	3^-	0.041
12.96	(3)	(3^-)	0.033
13.58	1	1^-	0.068
14.82	3	3^-	0.079
15.66	3	3^-	0.096

^a (1984PE24): $E_\alpha = 35$ MeV.

^b Excitation energies without uncertainties are from Table 14.3, except for the last three values.

^c Microscopic DWBA analysis.

^d Collective deformations.

^e Isoscalar transition rates $B(02)$ are 168, 96 and 74 fm⁴ for $^{14}\text{C}^*$ (7.01, 8.32, 10.44).

^{14}N
(Figs. 3 and 5)

GENERAL (See also (1986AJ01)).

Nuclear models: (1985KW02, 1986ZE1A, 1987KIIC, 1988WO04, 1989TA01, 1989WO1E, 1990HA07, 1990VA01)

Special states: (1985AD1A, 1985BA75, 1985GO1A, 1986ADZT, 1986AN07, 1986GO29, 1987BA2J, 1987BL15, 1987KIIC, 1987SU1G, 1988KW02, 1988WRZZ, 1989AM01, 1989OR02, 1989SU1E, 1989TA01)

Electromagnetic transitions and giant resonances: (1984VA06, 1985GO1A, 1985GO1B, 1986ER1A, 1987BA2J, 1987KIIC, 1988YA10, 1988WRZZ, 1989AM01)

Astrophysical questions: (1982CA1A, 1982WO1A, 1985BR1E, 1985DW1A, 1985PR1D, 1986CH1H, 1986DO1L, 1986HA2D, 1986LA1C, 1986MA1E, 1986SM1A, 1986TR1C, 1986WO1A, 1987AL1B, 1987AR1J, 1987AR1C, 1987AU1A, 1987BO1B, 1987CU1A, 1987DW1A, 1987ME1B, 1987MU1B, 1987PR1A, 1987RA1D, 1987WA1L, 1988BA86, 1988CUZX, 1988DU1B, 1988DU1G, 1988EP1A, 1988KR1G, 1988WA1I, 1989AB1J, 1989BO1M, 1989CH1X, 1989CH1Z, 1989DE1J, 1989DU1B, 1989GU1Q, 1989GU28, 1989GU1J, 1989GU1L, 1989HO1F, 1989JI1A, 1989KA1K, 1989KE1D, 1989ME1C, 1989NO1A, 1989PR1D, 1989WY1A, 1990HA07, 1990HO1I, 1990RO1E, 1990SI1A, 1990WE1I)

Complex reactions involving ^{14}N : (1984MA1P, 1984XI1B, 1985BE40, 1985KW03, 1985PO11, 1985RO10, 1985SH1G, 1985ST20, 1985ST1B, 1985WA22, 1986AI1A, 1986BO1B, 1986GR1A, 1986GR1B, 1986HA1B, 1986MA13, 1986MA19, 1986ME06, 1986PL02, 1986PO06, 1986SA30, 1986SH2B, 1986SH1F, 1986VA23, 1986WE1C, 1987BA38, 1987BE55, 1987BE58, 1987BO1K, 1987BU07, 1987FE1A, 1987GE1A, 1987GO17, 1987HI05, 1987JA06, 1987KO15, 1987LY04, 1987MU03, 1987NA01, 1987PA01, 1987RI03, 1987RO10, 1987SH23, 1987ST01, 1987TE1D, 1988AY03, 1988CA27, 1988GA12, 1988HA43, 1988KA1L, 1988LY1B, 1988MI28, 1988PAZS, 1988POZZ, 1988PO1F, 1988SA19, 1988SH03, 1988SI01, 1988TE03, 1988UT02, 1989BA92, 1989BR35, 1989CA15, 1989CEZZ, 1989GE11, 1989KI13, 1989MA45, 1989PO06, 1989PO07, 1989PR02, 1989SA10, 1989VO19, 1989YO02, 1989ZHZY, 1990BO04, 1990DE14, 1990GL01, 1990LE08, 1990PA01, 1990WE14, 1990YE02)

Applied work: (1985GO27, 1985KO1V, 1986BO1L, 1986CO1Q, 1986HE1F, 1986NO1C, 1986PH1A, 1986ST1K, 1986ZA1A, 1987SI1D, 1987ZA1D, 1988AL1K, 1988GO1M, 1988ILZZ, 1988RO1F, 1988RO1L, 1988ZA1A, 1990KO21)

Muon and neutrino capture and reactions: (1985AG1C, 1985KO39, 1986IS02, 1987SU06, 1988AL1H, 1988BU01, 1989MU1G, 1989NA01, 1990CH13, 1990GR1G)

Pion capture and reactions: (1983AS01, 1984AS05, 1985BE1C, 1985KO1Y, 1985LA20, 1985RO17, 1985TU1B, 1986AR1F, 1986BE1P, 1986CE04, 1986DY02, 1986ER1A, 1986GE06, 1986KO1G, 1986LAZL, 1986PE05, 1986RA1J, 1986RO03, 1986SU18, 1987AH1A, 1987BL15,

1987BO1D, 1987BO1E, 1987DOZY, 1987GI1B, 1987GI1C, 1987GO05, 1987KA39, 1987KO1O, 1987LE1E, 1987NA04, 1987RO23, 1988GIZU, 1988KO1V, 1988MI1K, 1988OH04, 1988TI06, 1989BA63, 1989CH31, 1989DI1B, 1989DO1L, 1989GA09, 1989GE10, 1989GIZW, 1989GIZV, 1989IT04, 1989KH08, 1989NA01, 1989RI05, 1990BE24, 1990CH12, 1990CH1S, 1990DI1D, 1990ER03, 1990ER1E, 1990GH01)

Kaon capture and reactions: (1985BE62, 1986BE42, 1986DA1G, 1986FE1A, 1986MA1C, 1986WU1C, 1989BEXX, 1989BEXU, 1989DO1I, 1989DO1K, 1989SI09)

Antinucleon reactions: (1986BA2W, 1986KO1E, 1986RO23, 1986SP01, 1987AH1A, 1987GR20, 1987HA1J, 1987PO05, 1989RI05, 1990JO01)

Table 14.10: Energy Levels of ^{14}N ^a

E_x in ^{14}N ^b (MeV \pm keV)	$J^\pi; T$	τ_m or $\Gamma_{c.m.}$ (keV)	Decay	Reactions
g.s.	$1^+; 0$	stable	-	6, 7, 8, 9, 10, 18, 19, 20, 21, 22, 23, 24, 25, 31, 32, 33, 34, 35, 36, 37, 38, 39, 40, 41, 42, 43, 44, 45, 46, 47, 48, 49, 50, 51, 52, 53, 54, 55, 56, 57, 58, 59, 60, 61, 62, 63, 64, 65
2.312798 ± 0.011	$0^+; 1$	$\tau_m = 98.7 \pm 4.5$ fs ^c	γ	8, 10, 18, 19, 20, 21, 24, 25, 31, 32, 33, 34, 36, 37, 38, 39, 42, 44, 45, 47, 57, 58, 59, 60, 61, 64, 65
3.94810 ± 0.20	$1^+; 0$	7.0 ± 2.5 fs ^d	γ	6, 7, 8, 10, 18, 19, 20, 21, 25, 31, 32, 33, 34, 37, 38, 39, 43, 44, 45, 46, 47, 48, 57, 58, 59, 60, 61
4.9151 ± 1.4	$0^-; 0$	7.6 ± 1.4 fs	γ	6, 7, 18, 19, 20, 21, 31, 32, 33, 34, 38, 43, 44, 45, 46, 47, 48, 59, 60, 61

Table 14.10: Energy Levels of $^{14}\text{N}^a$ (continued)

E_x in $^{14}\text{N}^b$ (MeV \pm keV)	$J^\pi; T$	τ_m or $\Gamma_{c.m.}$ (keV)	Decay	Reactions
5.10589 ± 0.10	$2^-; 0$	6.27 ± 0.07 ps	γ	1, 6, 7, 8, 10, 18, 19, 20, 21, 31, 32, 33, 34, 38, 39, 43, 44, 45, 46, 47, 48, 59, 60, 61, 64
5.69144 ± 0.13	$1^-; 0$	$ g = 0.66 \pm 0.04$ 16 ± 8 fs	γ	6, 7, 18, 19, 20, 21, 25, 31, 32, 34, 38, 43, 44, 45, 46, 47, 48, 59, 60, 61
5.83425 ± 0.14	$3^-; 0$	11.98 ± 0.23 ps	γ	1, 6, 7, 11, 18, 19, 20, 21, 23, 24, 31, 32, 34, 38, 39, 43, 44, 45, 46, 47, 48, 59, 60, 61
6.2035 ± 0.6	$1^+; 0$	160 ± 20 fs	γ	6, 7, 18, 19, 20, 21, 25, 31, 32, 38, 39, 45, 46, 47, 48, 59, 60, 61
6.44617 ± 0.10	$3^+; 0$	620 ± 60 fs	γ	6, 7, 18, 19, 20, 21, 25, 31, 32, 38, 45, 46, 48, 59, 60, 61
7.02912 ± 0.12	$2^+; 0$	5.4 ± 0.5 fs	γ	6, 7, 18, 19, 20, 21, 25, 31, 32, 34, 38, 39, 43, 44, 45, 46, 47, 48, 59, 60, 61
7.9669 ± 0.5	$2^-; 0$	$\Gamma = (2.5 \pm 0.7) \times 10^{-3}$	γ, p	6, 7, 18, 19, 20, 21, 25, 32, 45, 48, 59, 60, 61
8.062 ± 1.0	$1^-; 1$	23 ± 1	γ, p	18, 19, 25, 26, 31, 32, 41, 45, 47, 59, 61
8.490 ± 2	$4^-; 0$	$\tau_m = 19 \pm 3$ fs	γ, p	6, 7, 18, 19, 20, 21, 25, 31, 32, 39, 43, 45, 48, 60

Table 14.10: Energy Levels of ^{14}N ^a (continued)

E_x in ^{14}N ^b (MeV \pm keV)	$J^\pi; T$	τ_m or $\Gamma_{\text{c.m.}}$ (keV)	Decay	Reactions
8.618 ± 2	$0^+; 1$	$\Gamma = 3.8 \pm 0.3$	γ, p	8, 18, 19, 25, 26, 31, 32, 45, 59, 61
8.776 ± 7	$0^-; 1$	410 ± 20	γ, p	25, 26, 32
8.907 ± 3	$3^-; 1$	16 ± 2	γ, p	19, 25, 26, 31, 32, 42, 45, 59, 61
8.964 ± 2	$5^+; 0$	$\tau_m = 105 \pm 17$ fs	γ, p	7, 11, 19, 20, 21, 23, 25, 31, 32, 52, 59
8.980 ± 3	$2^+; (0)$	$\Gamma = 8 \pm 2$	γ, p	6, 7, 19, 25, 26, 31, 32, 59
9.1290 ± 0.5 ^e	$3^+; 0$	$\tau_m = 13 \pm 5$ fs	γ, p	6, 7, 19, 20, 25, 31, 32, 48
9.17225 ± 0.12	$2^+; 1$	$\Gamma = 0.122 \pm 0.008$ ^h	γ, p	19, 25, 31, 32, 42, 45, 59, 60, 61
9.388 ± 3	$2^-; 0$	13 ± 3	p	6, 7, 19, 20, 21, 26, 31, 32, 45, 48, 59, 60, 61
9.509 ± 3	$2^-; 1$	41 ± 2	γ, p	19, 25, 26, 31, 32, 45, 59, 60, 61
9.703 ± 4	$1^+; 0$	15 ± 3	p	6, 19, 21, 25, 26, 31, 32, 45, 59, 60, 61
10.079 ± 10	(3^+)	< 10		6, 7, 11, 19, 21, 32
10.101 ± 15	$2^+, 1^+; 0$	12 ± 3	γ, p	19, 21, 25, 26, 32, 45, 59, 60
10.226 ± 8	$1^{(-)}; 0$	80 ± 15	γ, p	19, 21, 25, 26, 32, 59
10.432 ± 7	$2^+; 1$	33 ± 3	γ, p	11, 19, 25, 26, 38, 42, 59, 60, 61
10.534 ± 20	(1^-)	140	p	19, 26, 32
10.812 ± 15	$5^+; 0$	$(0.39 \pm 0.16) \times 10^{-3}$	γ	6, 7, 11, 19, 20, 21, 32, 48
11.00 ± 30		165 ± 30	γ, p	25

Table 14.10: Energy Levels of ^{14}N ^a (continued)

E_x in ^{14}N ^b (MeV \pm keV)	$J^\pi; T$	τ_m or $\Gamma_{c.m.}$ (keV)	Decay	Reactions
11.050 \pm 5	3 ⁺	1.2 \pm 0.4	γ , p	6, 7, 11, 19, 21, 25, 32, 59, 60
11.07	1 ⁺ ; 0	100	n, p, d	13, 26, 27
11.21 \pm 30	$T = 1$	220 \pm 30	γ , p, d	13
11.24 \pm 15	3 ⁻ ; 0	11	γ , n, p	11, 19, 26, 27, 32, 42, 43, 45, 46, 47, 48, 59
11.27 \pm 15	2 ⁻ ; 0	180	n, p, d	6, 13, 14, 21, 26, 27, 32, 59
11.357 \pm 15	1 ⁺ ; 0	30	n, p, d	13, 14, 19, 26, 27, 59
11.5135 \pm 1.5	2 ⁺ ; 3 ⁺	7.0 \pm 0.5	p, d	6, 7, 11, 13, 14, 19, 21, 32, 42, 59, 60
11.676 \pm 18	1 ⁻ ; 2 ⁻	150 \pm 20	n, p, d	13, 14, 27, 32, 59
11.741 \pm 6	1 ⁻ ; 2 ⁻	40 \pm 9	(γ), p, d	13
11.761 \pm 6	3 ⁻ ; 4 ⁻	78 \pm 6	(γ), p, d	13
11.807 \pm 7	2 ⁻ ; (1 ⁺)	119 \pm 9	n, p, d	13, 14
11.874 \pm 6	2 ⁻ , (1 ⁻)	101 \pm 9	n, p, d	13, 27
12.20 \pm 19	1 ⁻ , 2 ⁻	300 \pm 30	n, p, d	13, 14, 27, 59
12.408 \pm 3	(4 ⁻)	34 \pm 3	n, p, d, α	3, 4, 13, 14, 21, 38
12.418 \pm 3	3 ⁻ , 4 ⁻	41 \pm 4	p, d	6, 11, 13, 19, 38
12.495 \pm 9	(1 ⁺ ; 1)	39 \pm 5	γ , n, p, d, α	3, 13, 19, 25, 42, 59, 60, 61
12.594 \pm 3	3 ⁺	48 \pm 2	(n), p, d, α	3, 13, 14, 19, 27, 48, 59
12.690 \pm 5	3 ⁻	18 \pm 5	n, p, d, α	3, 4, 5, 6, 7, 11, 13, 14, 19, 21, 27, 48
(12.708 \pm 9)		(43 \pm 15)	p, d	13
12.789 \pm 5	4 ⁺	16 \pm 3	n, p, d, α	3, 4, 5, 7, 11, 13, 14, 19, 45, 46, 47, 48, 59

Table 14.10: Energy Levels of $^{14}\text{N}^a$ (continued)

E_x in $^{14}\text{N}^b$ (MeV \pm keV)	$J^\pi; T$	τ_m or $\Gamma_{c.m.}$ (keV)	Decay	Reactions
12.813 \pm 4	4 ⁻	5 \pm 2	γ, p, d, α	3, 4, 6, 7, 13, 14, 38, 42, 43, 45, 46, 47, 48, 59, 60
12.826 \pm 6		11 \pm 3	n, p, d	13, 14
12.857 \pm 6		78 \pm 10	n, p, d	13, 21, 27
12.883 \pm 8		134 \pm 11	p, d	13
12.922 \pm 5	4 ⁺	22 \pm 4	p, d, α	3, 4, 11, 13, 14
13.007 \pm 17		120 \pm 30	γ, p	6, 7, 25
13.167 \pm 5	1 ⁺	15 \pm 5	γ, n, p, d, α	3, 4, 5, 6, 19, 42, 59
13.192 \pm 9	3 ⁺	65 \pm 10	α	5, 11, 59
13.243 \pm 10	2 ⁻	92 \pm 5	γ, n, p, α	2, 3, 27, 42, 48, 59
13.30 \pm 40	(2 ⁻); 1	1000 \pm 150	γ, p	25
13.656 \pm 5	(2 ⁺ , 3 ⁺)	\approx 90	n, p, d, α	3, 5, 13, 14
13.714 \pm 5	2 ⁻ , 3 ⁺	105 \pm 25	γ, n, p, d, α	2, 3, 4, 6, 11
13.74 \pm 10	1 ⁺ ; 1	180 \pm 20	(γ), n, p, d, α	2, 3, 5, 13, 14, 25, 27, 37, 42, 59, 60, 61
13.77 \pm 10	(1 ⁺)	120	p, α	3
14.04 \pm 30		100	n, p, d, α	2, 3, 13, 14, 27
14.16 \pm 30		230	n, p, d, α	2, 3, 13, 14
14.25 \pm 50	3 ⁺	420 \pm 100	p, α	3, 5
14.30 \pm 20		150	p, α	3
14.56 \pm 20		100	n, p, α	2, 3, 11
14.59 \pm 30		50	n, p, α	2, 3, 11
14.66 \pm 10	5 ⁻ ; 0	100 \pm 20	α	5, 43
14.73 \pm 25	(2 ⁻ ; 1)	125	γ, n, p, α	2, 3
14.86 \pm 30		140	n, p, d, α	2, 3, 6, 11, 13, 14, 16, 21, 27
14.92 \pm 30		43 \pm 8	n, p, α	2, 3, 11, 19, 27
15.02 \pm 20	3 ⁻ , 4 ⁻ ; 1	\approx 60	γ, n, p, α	2, 6, 20, 27, 42, 43

Table 14.10: Energy Levels of $^{14}\text{N}^a$ (continued)

E_x in $^{14}\text{N}^b$ (MeV \pm keV)	$J^\pi; T$	τ_m or $\Gamma_{c.m.}$ (keV)	Decay	Reactions
15.24 \pm 20		100	p, d, α	3, 6, 7, 11, 13, 14
15.43 \pm 20		100	n, p, d, α	2, 3, 13, 16, 21
15.70 \pm 50		350	γ , n, p, d, α	6, 13, 14, 16, 19, 21, 27, 42
16.21 \pm 20		125	n, p, α	2, 3, 21, 27, 60
16.40 \pm 20		150	p, d, α	3, 16
16.65 \pm 25 ^f	4 ⁺ ; 0 + 1	240 \pm 25	d, α	16
16.91 \pm 20	5 ⁻ ; 1	170 \pm 25	γ	11, 42, 43
16.91 \pm 30	4 ⁺ ; 0 + 1	290 \pm 30	p, d, α	16
16.92 \pm 20 ^g	2 ⁺ ; 0 + 1	830 \pm 170	d, α	16
17.03 \pm 50	3 ⁻ ; 0 + 1	245 \pm 50	d, α	16
17.17 \pm 30	1 ⁻ ; 0 + 1	300 \pm 30	γ , p, d, α	11, 16, 21, 42
17.31 \pm 30	4 ⁺ ; 0 + 1	275 \pm 30	d, α	16, 60
17.40 \pm 25	4 ⁺ ; 0 + 1	245 \pm 25	d, α	16
17.46	5 ⁻ ; 0			43
17.85 \pm 50 ^g	4 ⁺ ; 0 + 1	475 \pm 50	d, α	16
17.85 \pm 50 ^g	3 ⁻ ; 0 + 1	440 \pm 50	d, α	16
17.93 \pm 70 ^g	2 ⁺ ; 0 + 1	340 \pm 70	d, α	16
18.02 \pm 60	3 ⁻ ; 0 + 1	570 \pm 60	d, α	16
18.14 \pm 50	4 ⁺ ; 0 + 1	480 \pm 50	d, α	16
18.35 \pm 60	1 ⁻ ; 0 + 1	560 \pm 60	d, α	16
18.43 \pm 65	4 ⁺ ; 0 + 1	315 \pm 65	d, α	16
18.50 \pm 10	5 ⁻ ; 0 + 1	62 \pm 10	d, α	16, 42
18.53 \pm 80	2 ⁺ ; 0 + 1	410 \pm 80	d, α	16
18.53 \pm 60	3 ⁻ ; 0 + 1	310 \pm 60	d, α	16
18.64 \pm 70	3 ⁻ ; 0 + 1	675 \pm 70	d, α	16, 43
18.78 \pm 35	1 ⁻ ; 0 + 1	315 \pm 35	d, α	16
18.88 \pm 50	4 ⁺ ; 0 + 1	475 \pm 50	d, α	16
18.93 \pm 50	2 ⁺ , 3 ⁻ ; 0 + 1	450 \pm 50	d, α	16
19.10 \pm 90	3 ⁻ ; 0 + 1	870 \pm 90	d, α	16

Table 14.10: Energy Levels of ^{14}N ^a (continued)

E_x in ^{14}N ^b (MeV \pm keV)	$J^\pi; T$	τ_m or $\Gamma_{c.m.}$ (keV)	Decay	Reactions
19.90 \pm 60	2 ⁺ ; 0 + 1	575 \pm 60	d, α	16
19.99 \pm 50	1 ⁻ ; 0 + 1	510 \pm 50	d, α	16
(20.11 \pm 20)	3 ⁻ , 4 ⁻ ; 0 + 1	120 \pm 20	γ	42, 43
20.63 \pm 110	4 ⁺ ; 0 + 1	1100 \pm 110	d, α	16
20.65 \pm 60	5 ⁻ ; 0 + 1	610 \pm 60	d, α	16
21.24 \pm 50	4 ⁺ ; 0 + 1	415 \pm 50	d, α	16
21.51 \pm 25	3 ⁻ ; 0 + 1	235 \pm 25	d, α	16
21.53 \pm 75	5 ⁻ ; 0 + 1	360 \pm 75	d, α	16
21.68 \pm 40	4 ⁺ ; 0 + 1	360 \pm 40	d, α	16
21.8	4 ⁺ ; 0 + 1	650	γ , ^3He	9
22.26 \pm 15	4 ⁺ ; 0 + 1	65 \pm 15	d, α	16
22.31 \pm 60	5 ⁻ ; 0 + 1	570 \pm 60	d, α	16
22.5	2 ⁻ ; 1		γ , p	25
23.0	2 ⁻ ; 1	\approx 3000	γ , n, p	25, 40
23.40 \pm 70	5 ⁻ ; 0 + 1	640 \pm 70	d, α	16
24.0		\approx 1000	n, ^3He , α	9

^a See also Tables 14.13 and 14.14, and footnote ^b in Table 14.15 here (1986WA13).

^b I am indebted to E.K. Warburton for sending me a reanalysis of the E_x of many of the states in ^{14}N with $E_x < 9.4$ MeV: see, e.g., footnote ^b in Table 14.15.

^c Weighted mean of values displayed in Table 14.14 of (1986AJ01) but not using the value 79 ± 7 fs which has not been published, and including the value 97.7 ± 5.5 fs (1987ZI04).

^d Adopted value, based on values shown in Table 14.14 (1986AJ01) and on 5.6 ± 1.1 fs (1987ZI04).

^e The present evidence (1986WA13) only supports the presence of one state at $E_x \approx 9.13$ MeV, with $J^\pi = 3^+$. The only remaining evidence for a doublet is the $^{12}\text{C}(^3\text{He}, p')^{14}\text{N}(p)^{13}\text{C}_{g.s.}$ work by (1974NO01).

^f With the exception of $^{14}\text{N}^*(16.91, 17.46, 21.8, 22.5, 23.0, 24.0)$, this state and all higher states were derived from an S -matrix analysis of the $^{12}\text{C}(d, \alpha_1)$ reaction by (1981JO02).

^g See, however, Tables 14.20 and 14.21.

^h See reaction 41.

Hypernuclei: (1984BO1H, 1984ZH1B, 1986FE1A, 1986GA1H, 1986MA1C, 1986WU1C, 1986YA1Q, 1988MA1G, 1988MO1L, 1989BA92, 1989BA93, 1989DO1K, 1989IT04, 1989KO37, 1990IT1A)

Other topics: (1985AD1A, 1985AN28, 1986ADZT, 1986AN07, 1987BA2J, 1988GU1C, 1988HE1G, 1988KW02, 1989DE1O, 1989OR02, 1989PO1K, 1990MU10, 1990PR1B)

Ground state of ^{14}N : (1985AN28, 1985GO1A, 1985ZI05, 1986GL1A, 1986RO03, 1986WI04, 1987AB03, 1987KI1C, 1987VA26, 1988BI1A, 1988VA03, 1988WO04, 1988WRZZ, 1989AM01, 1989AN12, 1989GOZQ, 1989SA10, 1989WO1E, 1990BE24, 1990VA1G, 1990VA01)

$$\mu = +0.4037607 (2) \text{ nm (1978LEZA),}$$

$$Q = +0.0193 (8) \text{ b (1980WI22). See also (1986HA49) and (1989RA17),}$$

$$\langle r^2 \rangle^{1/2} = 2.560 (11) \text{ fm (1980SC18),}$$

Natural abundance: $(99.634 \pm 0.009)\%$ (1984DE53)

$$1. \text{}^9\text{Be}(^7\text{Li}, 2\text{n})^{14}\text{N} \quad Q_{\text{m}} = 7.249$$

The energy of the $5.83 \rightarrow 5.11 \gamma$ transition is $E_{\gamma} = 728.34 \pm 0.10 \text{ keV}$. When corrected for the nuclear recoil and added to $E_{\text{x}} = 5105.89 \pm 0.10 \text{ keV}$, $E_{\text{x}} = 5834.25 \pm 0.14 \text{ keV}$ for $^{14}\text{N}^*(5.83)$ (1981KO08) [recalculated]. For branching ratios see Table 14.11. See (1981KO08) also for a general discussion of electromagnetic transitions in ^{14}C and ^{14}N , and comparison with theory.

$$2. \text{}^{10}\text{B}(\alpha, \text{n})^{13}\text{N} \quad Q_{\text{m}} = 1.0590 \quad E_{\text{b}} = 11.6125$$

Observed resonances are displayed in Table 14.12. For thick target yields see (1989HE04). See also (1985CA41; astrophys.).

$$3. \text{}^{10}\text{B}(\alpha, \text{p})^{13}\text{C} \quad Q_{\text{m}} = 4.0618 \quad E_{\text{b}} = 11.6125$$

Excitation functions have been measured to $E_{\alpha} = 26 \text{ MeV}$. Observed resonances are displayed in Table 14.12. (1975WI04) has expanded the angular distributions of the $\text{p}_0 \rightarrow \text{p}_3$ groups into Legendre polynomials and fitted the coefficients at resonances corresponding to $^{14}\text{N}^*(13.16, 13.24, 13.67, 13.76)$ obtaining $J^{\pi} = 1^+, 2^-, 2 \text{ or } 3^+, \text{ and } 1$, respectively, for these states. However, an R -matrix analysis by (1983CS03) suggests $J^{\pi} = 2^-, 3^+, 1^+$ for $^{14}\text{N}^*(13.69, 13.74, 13.77)$. (1975WI04) finds that a surprising proportion of states have a higher cross section for neutron than for proton emission: the fluctuations of $\sigma_{\text{n}}/\sigma_{\text{p}}$ at low E_{α} suggest sizable isospin impurities in the ^{14}N states.

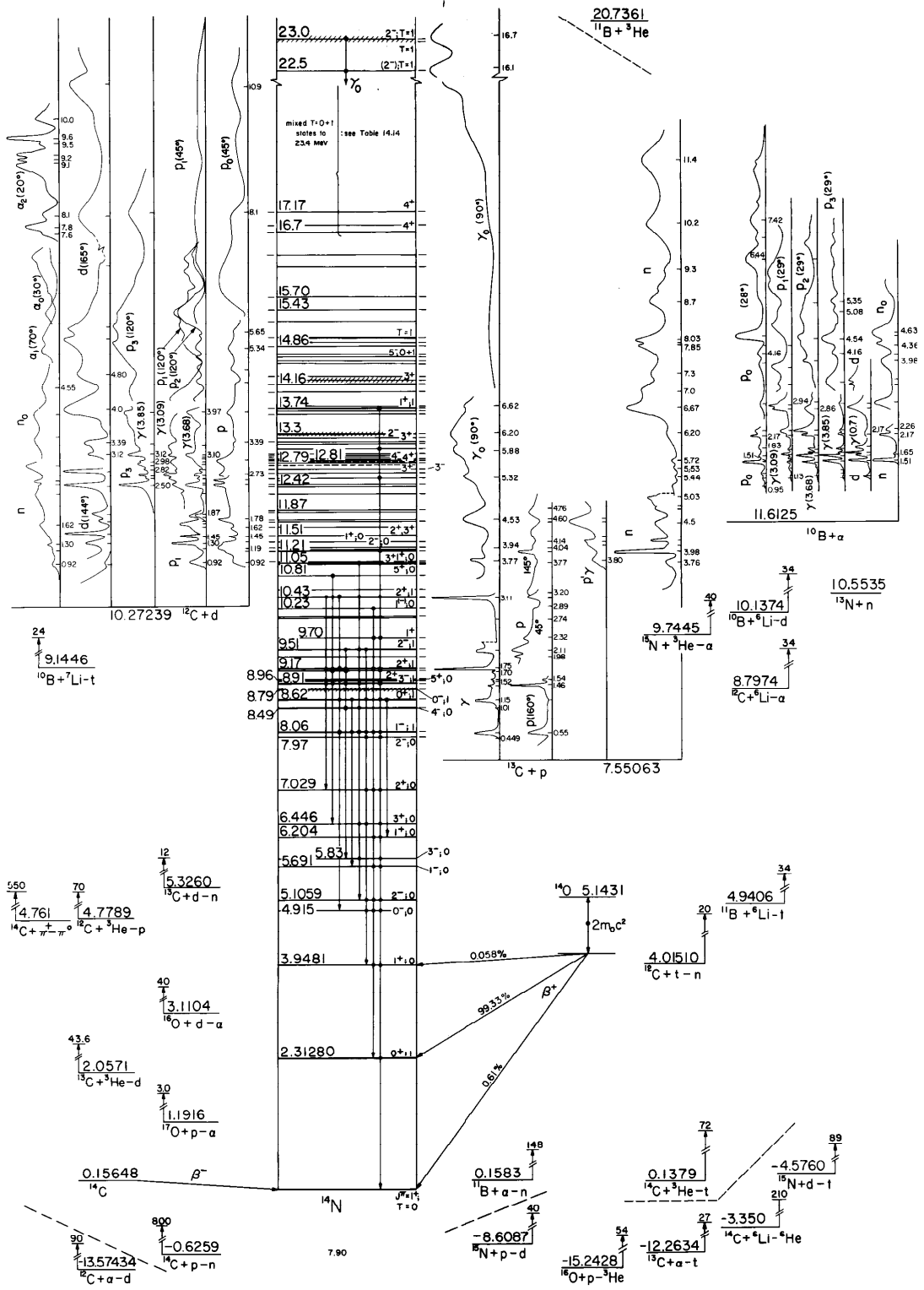

Figure 3: Energy levels of ^{14}N . For notation see Fig. 2.

Table 14.11: Radiative decays in $^{14}\text{N}^a$

E_i (MeV)	$J_i^\pi; T$	E_f (MeV)	$J_f^\pi; T$	Branch (%)	Γ_γ (eV)
2.31	$0^+; 1$	0	$1^+; 0$	100	$(6.7 \pm 0.3) \times 10^{-3}$
3.95	$1^+; 0$	0	$1^+; 0$	3.9 ± 0.2	(M1) 4×10^{-4} (E2) 3×10^{-3}
4.92	$0^-; 0$	2.31	$0^+; 1$	96.1 ± 0.3	0.091 ± 0.030
		0	$1^+; 0$	97 ± 3	$(8.4 \pm 1.6) \times 10^{-2}$
5.11	$2^-; 0$	2.31	$0^+; 1$	< 1	
		3.95	$1^+; 0$	^b	
		0	$1^+; 0$	79.9 ± 1.0	(E1) $(8.00 \pm 0.18) \times 10^{-5}$ ^c (M2) $(2.05 \pm 0.51) \times 10^{-6}$ ^{c, d} (E3) $(1.80 \pm 0.51) \times 10^{-6}$ ^{c, d}
5.69	$1^-; 0$	2.31	$0^+; 1$	19.4 ± 1.2	$(2.04 \pm 0.13) \times 10^{-5}$ ^c
		3.95	$1^+; 0$	(0.7 ± 0.4)	$(7.4 \pm 4.2) \times 10^{-7}$ ^c
		0	$1^+; 0$	36.1 ± 1.2 ^e	$(0.9 \pm 0.5) \times 10^{-2}$
5.83	$3^-; 0$	2.31	$0^+; 1$	63.9 ± 1.2 ^e	$(1.7 \pm 0.8) \times 10^{-2}$
		0	$1^+; 0$	21.3 ± 1.3 ^f	(M2) $(4.8 \pm 1.4) \times 10^{-6}$ ^c (E3) $(6.9 \pm 1.5) \times 10^{-6}$ ^c
6.20	$1^+; 0$	5.11	$2^-; 0$	78.7 ± 1.3 ^f	(M1) $(4.32 \pm 0.11) \times 10^{-5}$ ^c (E2) $(7_{-5}^{+8}) \times 10^{-8}$ ^c
		0	$1^+; 0$	23.1 ± 1.9 ^e	$(0.9 \pm 0.1) \times 10^{-3}$
6.45	$3^+; 0$	2.31	$0^+; 1$	76.9 ± 2.0 ^e	$(3.2 \pm 0.4) \times 10^{-3}$
		0	$1^+; 0$	70.1 ± 1.5 ^e	$(7.4 \pm 0.7) \times 10^{-4}$ ^g
		3.95	$1^+; 0$	19.7 ± 1.0 ^e	$(2.1 \pm 0.3) \times 10^{-4}$
		5.11	$2^-; 0$	6.5 ± 0.6 ^e	$(0.7 \pm 0.1) \times 10^{-4}$
		5.83	$3^-; 0$	3.7 ± 0.6 ^e	$(0.4 \pm 0.1) \times 10^{-4}$
7.03	$2^+; 0$	0	$1^+; 0$	98.6 ± 0.3	(M1) $(9.1 \pm 1.3) \times 10^{-2}$ ^h (E2) $(5.0 \pm 1.2) \times 10^{-2}$
		2.31	$0^+; 1$	0.5 ± 0.1	(E2) $(6.2 \pm 1.4) \times 10^{-4}$
		3.95	$1^+; 0$	0.9 ± 0.25	$< (11 \pm 0.3) \times 10^{-4}$
		0	$1^+; 0$	55 ± 3	0.010
7.97 ⁱ	$2^-; 0$	3.95	$1^+; 0$	45 ± 3	0.008

Table 14.11: Radiative decays in $^{14}\text{N}^a$ (continued)

E_i (MeV)	$J_i^\pi; T$	E_f (MeV)	$J_f^\pi; T$	Branch (%)	Γ_γ (eV)
8.06 ^f	1 ⁻ ; 1	0	1 ⁺ ; 0	80.3 ± 0.6	9.9 ± 2.5
		2.31	0 ⁺ ; 1	1.40 ± 0.14	0.17 ± 0.05
		3.95	1 ⁺ ; 0	12.7 ± 0.4	1.56 ± 0.40
		4.92	0 ⁻ ; 0	1.86 ± 0.14	0.23 ± 0.06
		5.11	2 ⁻ ; 0	0.25 ± 0.14	0.03 ± 0.02
		5.69	1 ⁻ ; 0	3.5 ± 0.4	0.43 ± 0.12
8.49 ^f	4 ⁻ ; 0	5.11	2 ⁻ ; 0	83 ± 3	(6.1 ± 1.5) × 10 ^{-3 j}
		5.83	3 ⁻ ; 0	17 ± 3	(1.3 ± 0.4) × 10 ^{-3 j}
8.62	0 ⁺ ; 1	0	1 ⁺ ; 0	23	1.20
		3.95	1 ⁺ ; 0	24	1.26
		5.69	1 ⁻ ; 0	13	0.69
		6.20	1 ⁺ ; 0	40	
8.79 ^f	0 ⁻ ; 1	0	1 ⁺ ; 0	90 ± 10	46 ± 12
8.91 ⁿ	3 ⁻ ; 1	0	1 ⁺ ; 0	2.9 ± 0.3	(11.0 ± 1.7) × 10 ⁻³
		5.11	2 ⁻ ; 0	4.2 ± 0.5	(1.6 ± 0.3) × 10 ⁻²
		5.83	3 ⁻ ; 0	84.3 ± 0.9	0.32 ± 0.04
		6.45	3 ⁺ ; 0	5.3 ± 0.6	(2.0 ± 0.3) × 10 ⁻²
		7.03	2 ⁺ ; 0	3.3 ± 0.5	(1.3 ± 0.2) × 10 ⁻²
8.96	5 ⁺ ; 0	0	1 ⁺ ; 0	< 1	
		6.45	3 ⁺ ; 0	100	(1.2 ± 0.2) × 10 ^{-3 k}
9.13	3 ⁺ ; 0	0	1 ⁺ ; 0	82 ± 3	(8.5 ± 1.0) × 10 ^{-3 l}
		5.83	3 ⁻ ; 0	9 ± 3	(0.9 ± 0.3) × 10 ^{-3 l}
		6.45	3 ⁺ ; 0	9 ± 3	(0.9 ± 0.3) × 10 ^{-3 l}
9.17 ^m	2 ⁺ ; 1	0	1 ⁺ ; 0	85.9 ± 1.0 ^e	5.4 ± 0.3
		2.31	0 ⁺ ; 1	0.86 ± 0.08 ^e	(5.4 ± 0.6) × 10 ⁻²
		5.69	1 ⁻ ; 0	0.50 ± 0.10 ^e	(3.2 ± 0.7) × 10 ⁻²
		5.83	3 ⁻ ; 0	0.62 ± 0.08 ^e	(3.9 ± 0.6) × 10 ⁻²
		6.45	3 ⁺ ; 0	8.9 ± 0.8 ^e	0.56 ± 0.06
		7.03	2 ⁺ ; 0	3.2 ± 0.3 ^e	0.20 ± 0.03
9.51 ^p	2 ⁻ ; 1	0	1 ⁺ ; 0	0.6 ± 0.1	0.026 ± 0.006

Table 14.11: Radiative decays in ^{14}N ^a (continued)

E_i (MeV)	$J_i^\pi; T$	E_f (MeV)	$J_f^\pi; T$	Branch (%)	Γ_γ (eV)
9.70 ^p	1 ⁺ ; 0	3.95	1 ⁺ ; 0	6.6 ± 0.5	0.26 ± 0.04
		5.11	2 ⁻ ; 0	75.9 ± 4.7	3.02 ± 0.36
		5.83	3 ⁻ ; 0	16.8 ± 1.5	0.67 ± 0.10
		0	1 ⁺ ; 0	30 ± 7	0.018 ± 0.004
		2.31	0 ⁺ ; 1	70 ± 8	0.043 ± 0.005
10.10 ^p	2 ⁺ , 1 ⁺ ; 0	0	1 ⁺ ; 0	100	0.21 ± 0.02
10.23	1 ⁽⁻⁾ ; 0	2.31	0 ⁺ ; 1	≈ 100	4 ± 1.3
10.43 ^p	2 ⁺ ; 1	0	1 ⁺ ; 0	83 ± 3	10.8 ± 0.6
		5.11	2 ⁻ ; 0	2.4 ± 0.2	0.31 ± 0.03
		5.69	1 ⁻ ; 0	1.6 ± 0.4	0.21 ± 0.05
		6.45	3 ⁺ ; 0	6.5 ± 0.3	0.85 ± 0.06
		7.03	2 ⁺ ; 0	6.5 ± 0.3	0.85 ± 0.06
10.81	5 ⁺ ; 0	6.45	3 ⁺ ; 0	100	(1.6 ± 0.7) × 10 ⁻² °
11.05	3 ⁺	0	1 ⁺ ; 0		0.12 ± 0.02
		3.95	1 ⁺ ; 0		0.09 ± 0.02

^a See Table 14.11 in (1981AJ01) for the earlier references and for additional comments. See also Table 14.14 in (1986AJ01) and (1981KO08) for additional discussions.

^b Two values have been reported: 1.3 ± 1.0 and $\leq 0.5\%$.

^c (1982BH06).

^d $\delta(\text{M2/E1}) = -0.16 \pm 0.02$, $\delta(\text{E3/E1}) = -0.15 \pm 0.025$: see (1981KO08).

^e Recalculated to sum to 100%: see Table 14.11 in (1981AJ01).

^f (1981KO08).

^g $\delta(\text{M3/E2}) = -0.004 \pm 0.010$.

^h $\delta(\text{E2/M1}) = 0.74 \pm 0.09$.

ⁱ $\Gamma_\gamma/\Gamma = (0.7 \pm 0.2)\%$; $(2J+1)\Gamma_p = 12.6 \pm 3.6$ eV; $\Gamma = 2.5 \pm 0.7$ eV.

^j $\Gamma = (3.5 \pm 0.5) \times 10^{-2}$ eV from Table 14.14 in (1986AJ01); $\Gamma_p/\Gamma = 3.7 \pm 1.1$ [see (1981AJ01)] leads to $\Gamma_\gamma = 7.4 \pm 2.5$ meV.

^k $\Gamma = 6.3 \pm 1.0$ meV from Table 14.14 (1986AJ01); $\Gamma_p/\Gamma = 4.1 \pm 0.5$.

^l $\Gamma_p = 43_{+31}^{-15}$ meV; $\delta(\text{M3/E2}) = -0.03 \pm 0.02$.

^m $\Gamma_\gamma = 6.3 \pm 0.3$ eV: see Table 14.19.

ⁿ (1986ZI08). See also (1981KO08, 1985PR03).

^o $\Gamma_\gamma/\Gamma = (4.1 \pm 0.8)\%$; $\Gamma = 0.39 \pm 0.16$ eV.

^p (1985PR03).

4. (a) $^{10}\text{B}(\alpha, \text{d})^{12}\text{C}$ $Q_{\text{m}} = 1.3401$ $E_{\text{b}} = 11.6125$
 (b) $^{10}\text{B}(\alpha, \text{t})^{11}\text{C}$ $Q_{\text{m}} = -11.1244$

Excitation curves have been measured at E_{α} up to 27 MeV [see (1970AJ04, 1976AJ04, 1981AJ01)]. The low energy resonances are exhibited in Table 14.12. At the higher energies the yield curves are fairly smooth although broad resonances in the d_1 and d_0 yields corresponding to $^{14}\text{N}^*(23.25)$, respectively have been reported as has a sharp rise in the 15.1 MeV γ yield ≈ 1 MeV above the $^{12}\text{C}^*(15.1) + \text{p} + \text{n}$ threshold, a channel which is not isospin forbidden: see (1981AJ01). For cross sections at $E_{\alpha} = 29.5$ MeV (reaction (a)) and 25.0 and 30.1 MeV (reaction (b)) see (1983VA28). See also ^{12}C in (1990AJ01) and (1989VA07).

5. $^{10}\text{B}(\alpha, \alpha)^{10}\text{B}$ $E_{\text{b}} = 11.6125$

The yield of α -particles [and of 0.7 MeV γ -rays for $E_{\alpha} = 2.1$ to 3 MeV] has been measured for E_{α} to 50.6 MeV: see (1981AJ01). Observed resonances are displayed in Table 14.12. In addition to two strong resonances in the α_0 yields at $E_{\alpha} = 2.21$ and 4.26 MeV ($^{14}\text{N}^*(13.19, 14.66)$), two other states ($^{14}\text{N}^*(13.72, 14.25)$) are required to fit the data: an R -matrix calculation leads to $J^{\pi} = 3^+$, 1^+ [see, however, (1975WI04)], 3^+ and 2^- for $^{14}\text{N}^*(13.19, 13.72, 14.25, 14.66)$: see (1981AJ01).

6. $^{10}\text{B}(^6\text{Li}, \text{d})^{14}\text{N}$ $Q_{\text{m}} = 10.1374$

States with $E_x > 10$ MeV studied in this reaction at $E(^6\text{Li}) = 34$ MeV are displayed in Table 14.13 (1984CL08). In addition most of the lower-lying $T = 0$ states have been populated: see (1970AJ04, 1981AJ01).

7. $^{10}\text{B}(^7\text{Li}, \text{t})^{14}\text{N}$ $Q_{\text{m}} = 9.1446$

At $E(^7\text{Li}) = 24$ MeV angular distributions of the tritons to $^{14}\text{N}^*(3.95, 5.83, 6.45, 8.96, 9.13, 10.06, 10.81, 12.79 + 12.81, 13.03, 15.26)$ have been studied. $^{14}\text{N}^*(4.91, 5.11, 5.69, 6.20, 7.03, 7.97, 8.49, 8.98, 9.39, 11.05, 11.51, 12.42)$ are also populated: see (1981AJ01).

8. $^{10}\text{B}(^9\text{Be}, \alpha\text{n})^{14}\text{N}$ $Q_{\text{m}} = 10.0390$

For cross sections see (1986CU02).

Table 14.12: Resonances in $^{10}\text{B} + \alpha$ ^a

E_α (MeV \pm keV)	$\Gamma_{\text{c.m.}}$ (keV)	Outgoing particle ^b (x)	$^{14}\text{N}^*$ (MeV)	J^π
0.95		p_0	12.29	
1.13 ± 5	30 ± 5	$p_0 \rightarrow p_3, d$	12.42	4^-
1.20 ± 5	≈ 20	$p_0, (p_2), p_3$	12.47	
1.23 ± 5	35 ± 5	p_0, p_3	12.49	
1.40 ± 5	46 ± 4	$p_1, p_2, (p_3)$	12.61	3^+
1.507 ± 5	18 ± 5	$n_0, p_0, p_1, p_2, p_3, d, \alpha^c$	12.689	3^-
1.645 ± 5	16 ± 3	$n_0, p_0, p_1, p_2, p_3, d, \alpha^d$	12.787	4^+
1.68 ± 5	5 ± 2	p_1, p_2, p_3, d	12.812	4^-
1.83 ± 5	22 ± 4	$p_0 \rightarrow p_3, d$	12.919	4^+
2.174 ± 5	15 ± 5	$n_0, p_0 \rightarrow p_3, d, \alpha_1$	13.165	1^+
2.21 ± 10	65 ± 10	α_0	13.191	3^+
2.281 ± 10	92 ± 5	$n_0, p_0 \rightarrow p_3$	13.241	2^-
2.86 ± 5	≈ 90	n_0, p_1, p_2, α_1	13.655	
2.94 ± 5	105 ± 25	$n_0, p_0 \rightarrow p_3, d$	13.712	$2^-, 3^+$
2.98 ± 10	180 ± 20	$n_0, p_0, p_1, (p_2), \alpha_0$	13.74	$3^+, 1^{(+)}$
3.02 ± 10	120	p_1, p_3	13.77	(1^+)
3.40 ± 30	100	n_0, p_1	14.04	
3.56 ± 30	230	$n_0, (p_0), p_3$	14.16	
3.69 ± 50	420 ± 100	p, α_0	14.25	3^+
3.76 ± 20	150	p_1	14.30	
3.98 ± 20	100	n_0, p_0, p_2	14.56	
4.16 ± 30	50	n_0, p_0, p_3	14.59	
4.26 ± 10	100 ± 20	α_0	14.65	2^-
4.36 ± 30	125	$n_0, p_0, p_1, (p_2)$	14.73	
4.54 ± 30	140	n_0, p_2, p_3	14.86	
4.633 ± 30	43 ± 8	n_0, n_{2+3}, p_0	14.92	
4.77 ± 20	≈ 60	n_0, n_1	15.02	
5.08 ± 20	100	p_3	15.24	
5.35 ± 20	100	n_1, p_2, p_3	15.43	
6.44 ± 20	125	n_0, p_0, p_2	16.21	

Table 14.12: Resonances in $^{10}\text{B} + \alpha$ ^a (continued)

E_α (MeV \pm keV)	$\Gamma_{\text{c.m.}}$ (keV)	Outgoing particle ^b (x)	$^{14}\text{N}^*$ (MeV)	J^π
6.70 ± 20	150	p ₂	16.40	
7.42 ± 20		p ₀	16.91	
7.78 ± 20	50	p ₃	17.17	

^a See references in Tables 14.13 in (1981AJ01) and 14.15 in (1986AJ01), as well as in (1970AJ04, 1976AJ04).

^b n₀, n₁, n₂₊₃ correspond to $^{13}\text{N}^*(0, 2.37, 3.51 + 3.55)$; p₀, p₁, p₂, p₃ correspond to $^{13}\text{C}^*(0, 3.09, 3.68, 3.85)$ and the corresponding γ -rays; α_1 corresponds to the transition to $^{10}\text{B}^*(0.7)$. For θ_x^2 see Table 14.8 in (1970AJ04).

^c $\Gamma_x = 4.3, 0.62, 0.17, 0.70, 5.6, 0.93, 1.7$ keV for n₀, p₀, p₁, p₂, p₃, d, α .

^d $\Gamma_x = \leq 0.6, 0.18, 0.085, 0.44, 9.6, 2.0, 1.0$ keV for n₀, p₀, p₁, p₂, p₃, d, α .

9. (a) $^{11}\text{B}(^3\text{He}, \gamma)^{14}\text{N}$	$Q_m = 20.7361$	
(b) $^{11}\text{B}(^3\text{He}, n)^{13}\text{N}$	$Q_m = 10.1826$	$E_b = 20.7361$
(c) $^{11}\text{B}(^3\text{He}, p)^{13}\text{C}$	$Q_m = 13.1855$	
(d) $^{11}\text{B}(^3\text{He}, d)^{12}\text{C}$	$Q_m = 10.4637$	
(e) $^{11}\text{B}(^3\text{He}, t)^{11}\text{C}$	$Q_m = -2.001$	
(f) $^{11}\text{B}(^3\text{He}, ^3\text{He})^{11}\text{B}$		
(g) $^{11}\text{B}(^3\text{He}, \alpha)^{10}\text{B}$	$Q_m = 9.1236$	
(h) $^{11}\text{B}(^3\text{He}, ^6\text{Li})^8\text{Be}$	$Q_m = 4.5721$	

The capture γ -rays [reaction (a)] have been studied at $E(^3\text{He}) = 0.9$ to 2.6 MeV ($\theta = 0^\circ, 90^\circ$). When the barrier penetration factor has been removed a single resonance is observed at $E(^3\text{He}) \approx 1.4$ MeV [$^{14}\text{N}^*(21.8)$], $\Gamma_{\text{c.m.}} = 0.65$ MeV.

The excitation function for reaction (b) has been measured for $E(^3\text{He}) = 1.5$ to 18 MeV [see (1981AJ01)]. A broad peak at $E(^3\text{He}) = 4.15$ MeV may indicate the existence of $^{14}\text{N}^*(24)$, $\Gamma \approx 1$ MeV.

Yield curves for protons (reaction (c)) have been measured for $E(^3\text{He}) = 3.0$ to 5.5 MeV (p₀, p₁, p₁ + p₂ + p₃): they are rather featureless. This is also true for the ground-state deuterons of reaction (d) in the same energy interval. Yield curves for reaction (e) have been measured for $E(^3\text{He}) = 6$ to 30 MeV: see (1976AJ04). A_y measurements for t₀ and t₁ are reported at $E(^3\text{He}) = 33$ MeV: see (1986AJ01). See also ^{13}C and ^{13}N , and ^{11}B , ^{11}C , ^{12}C in (1990AJ01).

The excitation functions for α -particle groups [reaction (g)] have been measured for $E(^3\text{He}) = 0.9$ to 5.5 MeV: see (1976AJ04). No significant resonance behavior is seen except for the α_2 group which, in the 15° excitation function, exhibits a resonance at $E(^3\text{He}) = 4$ MeV, $\Gamma \approx 1$ MeV. See also ^{10}B in (1988AJ01).

The excitation function for reaction (h) to $^6\text{Li}_{\text{g.s.}} + ^8\text{Be}_{\text{g.s.}}$ has been measured for $E(^3\text{He}) = 1.4$ to 5.8 MeV: no pronounced structure is observed. At $E(^3\text{He}) = 25.20$ to 26.25 MeV the excitation functions for the transitions to $^8\text{Be}^*(0, 16.63, 16.91, 17.64)$ are smooth, indicating a predominantly direct reaction mechanism: see (1976AJ04).

$$10. \ ^{11}\text{B}(\alpha, \text{n})^{14}\text{N} \quad Q_{\text{m}} = 0.1583$$

For angular distributions to $E_{\alpha} = 13.9$ MeV see (1981AJ01). At $E_{\alpha} = 47.4$ MeV, $\theta = 0^\circ$, unresolved groups are reported to $E_x = 5.2, 8.6, 14.71, 16.84, 19.10, 20.52, 21.72, 22.38, 23.57$ and 24.25 MeV (1988LU02). [See for comments about dominant J^π : high-spin states are expected to be preferentially populated.] Uncertainties in E_x are ± 0.35 MeV for 15 MeV neutrons to 1.5 MeV for 30 MeV neutrons. Widths could not be determined. A state at ≈ 25 MeV was also populated [J.D. Brown, private communication]. See also ^{15}N , (1986AJ01) and (1988CA26; astrophys.).

$$11. \ ^{11}\text{B}(^6\text{Li}, \text{t})^{14}\text{N} \quad Q_{\text{m}} = 4.9406$$

States with $E_x > 10$ MeV studied in this reaction at $E(^6\text{Li}) = 34$ MeV are displayed in Table 14.13 (1984CL08).

$$12. \ ^{12}\text{C}(\text{d}, \gamma)^{14}\text{N} \quad Q_{\text{m}} = 10.27239$$

At $E_{\text{d}} = 1.5$ MeV the capture cross section is $< 1 \mu\text{b}$: see (1970AJ04). See also (1984NA1F). See also (1990HA46).

$$\begin{array}{lll} 13. \text{ (a) } ^{12}\text{C}(\text{d}, \text{n})^{13}\text{N} & Q_{\text{m}} = -0.2811 & E_{\text{b}} = 10.27239 \\ \text{ (b) } ^{12}\text{C}(\text{d}, \text{p})^{13}\text{C} & Q_{\text{m}} = 2.7218 & \\ \text{ (c) } ^{12}\text{C}(\text{d}, 2\text{p})^{12}\text{B} & Q_{\text{m}} = -14.812 & \end{array}$$

Table 14.13: States in ^{14}N from $^{10}\text{B}(^6\text{Li}, \text{d})$, $^{11}\text{B}(^6\text{Li}, \text{t})$, $^{12}\text{C}(^6\text{Li}, \alpha)$ ^a

E_x (MeV \pm keV) ^b	$d\sigma/d\Omega_{\text{c.m.}}$ ($\mu\text{b}/\text{sr}$) ^c		
	A	B	C
10.07 \pm 15	266	262	290
10.43 \pm 15		88	
10.81 \pm 15	234	164	
11.05 \pm 15	82	64	770
11.24 \pm 15		118	
11.27 \pm 15	74		1510
11.51 \pm 20	102	65	1170
11.79 \pm 20	55		
12.42 \pm 15	68	305	2702
12.66 \pm 30	82	286	1175
12.79 \pm 15		434	
12.81 \pm 15	149		
12.85 \pm 30			4960
12.92 \pm 20		324	
13.00 \pm 30	138		
13.19 \pm 20	80	234	
13.71 \pm 20	34	202	
14.57 \pm 20	183	217	
14.81 \pm 25		332	
14.85 \pm 30	189		2325
14.95 \pm 30		515	
15.00 \pm 30	157		
15.24 \pm 20	141	540	
15.40 \pm 50			1653
15.70 \pm 50	51		3530
16.20 \pm 50			1830
16.80 \pm 40		246	
16.91 \pm 30		297	
17.17 \pm 30		712	4860

A: $^{10}\text{B}(^6\text{Li}, \text{d}); E(^6\text{Li}) = 34 \text{ MeV}$.

B: $^{11}\text{B}(^6\text{Li}, \text{t}); E(^6\text{Li}) = 34 \text{ MeV}$.

C: $^{12}\text{C}(^6\text{Li}, \alpha); E(^6\text{Li}) = 32 \text{ MeV}$.

^a (1984CL08): see for angular distributions and for discussion of analog states in ^{14}C .

^b States below $E_x = 10 \text{ MeV}$ are not displayed here.

^c At $\theta_{\text{lab}} = 10^\circ$. Uncertainties in the differential cross sections are approximately $\pm 20\%$.

Resonances in the yields of neutrons and protons are displayed in Table 14.14. The 0° yield of neutrons shows broad structures at $E_d \approx 7.2$ and 11.5 MeV [n_0] and 8 and $(10.8) \text{ MeV}$ [n_1] as well as a sharper structure at $E_d \approx 9.5 \text{ MeV}$: see (1986AJ01).

Polarization measurements for both reactions (a) and (b) have been made at many energies. For the earlier work see (1970AJ04, 1976AJ04, 1981AJ01, 1986AJ01). Recent studies have been reported for reaction (b) at $E_d = 0.25 \rightarrow 1.10 \text{ MeV}$ (1986KO08; p_0) and at $E_d = 12 \text{ MeV}$ (1988LA03; ^{13}C states with $E_x < 7.7 \text{ MeV}$; VAP, TAP), 56 MeV (1986SA2G; $p_0, p_1; K_{yy}^y$ and $K_{yy}^{y'}$; prelim.), 2.1 GeV (1987PE19, 1989PU01; TAP; deuteron breakup), and $9.1 \text{ GeV}/c$ (1988AB13; TAP). For the breakup at high energies see also (1984KO42, 1989AV02, 1989BE2K). For reaction (c) to $^{12}\text{B}^*(0, 4.4[\text{u}])$ at $E_d = 70 \text{ MeV}$ see (1986MO27, 1988MO11; VAP, TAP) [see (1986MO27) for comment re lower energy measurement at 0°]. For a study of the Δ -region at $E_d = 2 \text{ GeV}$ see (1989EL05).

Table 14.14: Resonances in $^{12}\text{C} + \text{d}$ ^a

E_d (MeV \pm keV)	$\Gamma_{\text{c.m.}}$ (keV)	Particles out	$^{14}\text{N}^*$ (MeV)	$J^\pi; T$
0.92	95	n, p_0, p_1	11.06	$1^+, 0$
1.13		p_0, p_1	11.24	$T = 1$
1.19	190	n, p_0, p_1, d	11.29	$2^-; 0$
1.23		p_0	11.33	(3^+)
1.30	30	n, p_0, p_1, d	11.39	$1^+; 0$
1.39		p_0	11.46	(2^-)
1.4495 ± 1.5	7.0 ± 0.5	p_0, p_1, d	11.5135	$2^+, 3^+$
1.55		p_0	11.60	(2^-)
1.640 ± 20	150 ± 20	n, p_1, d_0	11.68	$1^-, 2^-$
1.715 ± 6	40 ± 9	p_2	11.741	$1^-, 2^-$
1.738 ± 6	78 ± 6	p_1	11.761	$3^-, 4^-, (2^-)$
1.792 ± 7	119 ± 9	n, $p_0, p_1, p_2, \text{d}_0$	11.807	$2^-, (1^+)$
1.870 ± 6	101 ± 9	p_0, p_1, p_2	11.874	$2^-, (1^-)$
2.250 ± 19	300 ± 30	n, $p_0 \rightarrow p_3, \text{d}_0$	12.20	$1^-, 2^-$
2.494 ± 3^b	37 ± 4	n, $p_0 \rightarrow p_3, \text{d}_0$	12.408	$3^+, (3^-, 4^-)$

Table 14.14: Resonances in $^{12}\text{C} + \text{d}$ ^a

E_d (MeV \pm keV)	$\Gamma_{\text{c.m.}}$ (keV)	Particles out	$^{14}\text{N}^*$ (MeV)	$J^\pi; T$
2.506 \pm 3	41 \pm 4	p ₁	12.418	3 ⁻ , 4 ⁻ , (2 ⁺ , 3 ⁺)
2.610 \pm 20	30 \pm 20	n, p ₁ , p ₂ , p ₃	12.507	
2.712 \pm 3	48 \pm 2	(n), p ₀ \rightarrow p ₃ , d ₀	12.594	3 ⁺
(2.817 \pm 7)	27 \pm 6	n, p ₁ , p ₂ , p ₃ , d ₀	(12.684)	
2.844 \pm 9	43 \pm 15	p ₂ , p ₃	12.708	
2.940 \pm 10	30 \pm 10	p ₂ , p ₃ , d	12.790	
2.967 \pm 5	37 \pm 6	p ₁	12.813	
2.982 \pm 6	11 \pm 3	n, p ₃ , d	12.826	
3.018 \pm 6	78 \pm 10	n, p ₀ , p ₁	12.857	
3.049 \pm 8	134 \pm 11	p ₁	12.883	
3.100 \pm 10	20 \pm 14	p ₁ , p ₂ , p ₃ , d	12.927	(3 ⁻ , 4 ⁻)
3.39 \pm 12	47 \pm 15	n, p ₂ , p ₃ , d	13.17	(0 ⁻ , 1 ⁻)
3.97 \pm 30	< 200	p ₀ , p ₂ , p ₃ , (d)	13.67	(2 ⁺ , 3 ⁺)
4.02 ⁺²⁰ ₋₁₀	\approx 235	n, (p), d	13.71	(1 ⁺)
4.40		p ₀ \rightarrow p ₃ , d	14.04	
4.55		n, p ₂ , d	14.17	
4.80		p ₀ , p ₂ , d	14.38	
5.17		d	14.70	
5.34	\approx 100	p ₀ \rightarrow p ₃ , d, α	14.84	
5.65		d	15.11	
5.83		p ₁ , p ₃ , d	15.26	
6.07		p ₁ , p ₂ , α	15.47	
6.3		p ₀ , p ₃ , d, α	15.7	
7.2		α	16.4	
7.448 ^c	240	α_2	16.65 ^d	4 ⁺
7.760 ^d	828	α_2	16.92	2 ⁺
7.784	293	α_2	16.94	4 ⁺
7.887	246	α_2	17.03	3 ⁻
8.034	307	α_2	17.15	1 ⁻
8.217	275	α_2	17.31	4 ⁺

Table 14.14: Resonances in $^{12}\text{C} + \text{d}$ ^a

E_d (MeV \pm keV)	$\Gamma_{\text{c.m.}}$ (keV)	Particles out	$^{14}\text{N}^*$ (MeV)	$J^\pi; T$
8.327	244	α_2	17.40	4^+
8.851	473	α_2	17.85	4^+
8.852	437	α_2	17.85	3^-
8.942 ^d	336	α_2	17.93	2^+
9.051	567	α_2	18.02	3^-
9.186	481	α_2	18.14	4^+
9.433	558	α_2	18.35	1^-
9.530 ^d	313	α_2	18.43	4^+
9.610	62	α_2	18.50	5^-
9.637 ^d	410	α_2	18.53	2^+
9.647 ^d	312	α_2	18.53	3^-
9.768	673	α_2	18.64	3^-
9.939	314	α_2	18.78	1^-
10.057	475	α_2	18.88	4^+
10.112	452	α_2	18.93	$2^+, 3^-$
10.306	872	α_2	19.10	3^-
11.237	575	α_2	19.90	2^+
11.348	506	α_2	19.99	1^-
12.094	1071	α_2, α_3	20.63	4^+
12.122	612	α_2	20.65	5^-
12.809	414	α_2	21.24	4^+
13.124	233	α_2	21.51	3^-
13.148 ^d	362	α_2	21.53	5^-
13.323	357	α_2	21.68	4^+
14.002 ^d	65	α_2	22.26	4^+
14.054	568	α_2	22.31	5^-
15.334	640	α_2	23.40	5^-

^a For references see Table 14.15 in (1976AJ04). See also Table 14.10 in (1970AJ04).

^b A study of this resonance shows that either f-shell components are present in the wave function or that the coupling is very strong or that both effects are present.

^c S -matrix analysis of α_2 by (1981JO02) leads to the resonance parameters for the states shown below, all of which are isospin-mixed. See also Table 14.14 in (1981AJ01) and Table 1 in (1981JO02). Uncertainties in $\Gamma_{c.m.}$ and E_x are about 10% of $\Gamma_{c.m.}$.

^d Uncertainties in $\Gamma_{c.m.}$ and E_x are about 20% of $\Gamma_{c.m.}$.

For a study of the (\vec{d} , $p\vec{X}$) reaction at $E_{\vec{d}} = 65$ MeV see (1989IE01). For a report on high-energy γ -ray production see (1989NI1D). For pion production see (1986AJ01) and (1987AG1A). For total cross sections see (1986AJ01) and (1987KI1J; prelim.; 2.0 to 4.0 GeV/c). See also (1984NA1F, 1989NA1R) and (1986AI04; applied).

14. $^{12}\text{C}(d, d)^{12}\text{C}$

$$E_b = 10.27239$$

Reported resonances are displayed in Table 14.14. For a listing of excitation function measurements see (1976AJ04). A recent study is reported by (1986HO26; $E_d = 0.60$ to 1.10 MeV; d_0). For the earlier polarization measurements see (1976AJ04, 1981AJ01, 1986AJ01). $A_y = 0.412 \pm 0.011$ at $E_{\vec{d}} = 56$ MeV ($\theta = 47.5^\circ$), and VAP and TAP have been studied for $E_{\vec{d}} = 35$ to 70 MeV (1985KA1A, 1986KA1Z). Studies of VAP and TAP have also been carried out at $E_{\vec{d}} = 56$ MeV (1986MA32; d_0) and 191 and 395 MeV (1986GA18; inclusive scattering; on C). At $E_{\vec{d}} = 400$ MeV, VAP and TAP measurements are reported for the groups to $^{12}\text{C}^*(4.4, 9.7, 12.7, 18.3)$ (1987AR1H; prelim.). For the (d, pn) reaction at $E_{\vec{d}} = 56$ MeV see (1989OK02).

See also (1987CA14), (1986CL1C, 1990BO11; applied), (1986YA1R) and (1989GOZN; theor.).

15. (a) $^{12}\text{C}(d, t)^{11}\text{C}$

$$Q_m = -12.4645$$

$$E_b = 10.27239$$

(b) $^{12}\text{C}(d, ^3\text{He})^{11}\text{B}$

$$Q_m = -10.4637$$

At $E_{\vec{d}} = 89.1$ MeV A_y measurements are reported for $^{11}\text{C}^*(0, 2.3)$ (1989SA13). For the earlier work see (1986AJ01).

16. $^{12}\text{C}(d, \alpha)^{10}\text{B}$

$$Q_m = -1.3401$$

$$E_b = 10.27239$$

Reported resonances are displayed in Table 14.14. The major interest in this reaction has been the study of the yield of the α_2 group to the $J^\pi = 0^+$, isospin “forbidden” $T = 1$ state. In particular, the work of (1971RI15, 1972SM07) has shown that while the α_0 , α_1 and α_3 yields show only weak fluctuations, the α_2 “forbidden” yield shows narrow resonances which implies that the source of

the isospin mixing (at least in the region which they, and the subsequent work of (1974JO01) studied: $E_d = 7.2$ to 16 MeV) is due to states in the ^{14}N compound nucleus. The ratio of the σ_t for the α_2 group compared to the α_t for the “allowed” groups is $\approx 1\%$, an order of magnitude greater than predicted by direct or multistep processes (1972SM07). An S -matrix analysis leads to the resonance parameters shown in Table 14.14 (1981JO02). For polarization measurements see (1986AJ01).

Table 14.15: States of ^{14}N from $^{12}\text{C}(^3\text{He}, p)^{14}\text{N}^a$

E_x (MeV \pm keV)	L	$J^\pi; T$	E_x (MeV \pm keV)	L	$J^\pi; T$
0	2		10.063 ± 15^e		$3^+, \geq 4$
2.319 ± 15	0		10.101 ± 15		$1^+, 2^+$
3.9502 ± 1.5^b	0		10.23		1
4.9153 ± 1.4^b	1		10.441 ± 15	g	$(2^+; 1)^h$
$\equiv 5.10587 \pm 0.18$	1		10.53		1, 2
5.6888 ± 1.4^b	1		10.812 ± 15		$5^+; 0$
5.8324 ± 1.4^b	3		11.053 ± 15		
6.2025 ± 1.4^b	0		11.249 ± 15		
6.4449 ± 1.4^b	2		11.357 ± 15		
7.0279 ± 1.4^b	2		11.517 ± 15		
7.9649 ± 1.4^b	3		f		
8.072 ± 15	1		12.29 ± 15		
$8.4864 \pm 1.5^{b,c}$	3	$4^-; 0$	12.425 ± 15		
8.6174 ± 4^b	0	$(0^+; 1)^h$	12.506 ± 15		
$8.9099 \pm 1.9^{b,d}$		$(3^-; 1)^h$	12.608 ± 15		
8.9598 ± 1.4^b			12.69 ± 15		
8.9773 ± 4^b		$(2^+; 0)^h$	12.80 ± 15		
9.1241 ± 1.5^b		$(3^+; 0)^i$	12.90 ± 25^f		
9.1674 ± 1.4^b	g	$(2^+; 1)^h$	13.15 ± 40		
$9.3854 \pm 1.64^{b,d}$		$2^-; 0^j$	14.91 ± 60		
9.51		$(2^-; 1)^h$	15.8 ± 200		
9.703 ± 15		$(1^+; 0)^h$	17.4 ± 200		

^a See Tables 14.14 in (1970AJ04), 14.18 in (1976AJ04) and 14.15 in (1981AJ01) for references.

^b A re-evaluation by (1986WA13) [based on an overall comparison with γ -ray values] of the E_x obtained by (1971DU03) leads to $E_x = 3948.10 \pm 0.20, 4915.1 \pm 1.4, 5105.89 \pm 0.10, 5691.44 \pm 0.13, 5834.25 \pm 0.14, 6203.6 \pm 1.4, 6446.17 \pm 0.10, 7029.12 \pm 0.12, 7966.9 \pm 0.5, 8490 \pm 2, 8618 \pm 2, 8907 \pm 3, 8964 \pm 2, 8980 \pm 3, 9129.0 \pm 0.5, 9172.25 \pm 0.12$ and 9388 ± 3 keV.

^c $\Gamma_p/\Gamma = 0.73 \pm 0.10$.

^d The widths of $^{14}\text{N}^*(8.91, 9.39)$ are, respectively, 19.7 ± 1.9 and 15.6 ± 2.0 keV.

^e $\Gamma < 10$ keV (J.W. Noe, private communication).

^f See Table 14.15 in (1981AJ01).

^g $\theta_p^2(l=3) = (2.3 \pm 1.1) \times 10^{-3}$ and $< 1.6 \times 10^{-3}$ for $^{14}\text{N}^*(9.17, 10.43)$.

^h Known from other data; consistent with the results in this reaction.

ⁱ See discussion in (1986WA13).

^j Or $J^\pi = 3^-$.

$$17. \text{}^{12}\text{C}(d, \text{}^6\text{Li})\text{}^8\text{Be} \qquad Q_m = -5.8916 \qquad E_b = 10.27239$$

Polarization measurements have been reported at $E_d = 18$ and 22 MeV (1987TA07; VAP, TAP; g.s.) and 51.7 MeV (1986YA12; VAP; $^8\text{Be}^*(0, 2.9, 11.4)$). See also (1981AJ01).

$$18. \text{}^{12}\text{C}(t, n)\text{}^{14}\text{N} \qquad Q_m = 4.01510$$

Angular distributions have been measured to states below 8.7 MeV at $E_t = 1.12$ to 1.68 MeV and at 8 MeV: see (1976AJ04).

$$19. \text{}^{12}\text{C}(\text{}^3\text{He}, p)\text{}^{14}\text{N} \qquad Q_m = 4.7789$$

Observed proton groups are displayed in Table 14.15. Angular distributions have been measured for $E(\text{}^3\text{He})$ to 25.3 MeV [see (1970AJ04, 1976AJ04)] and at $E(\text{}^3\vec{\text{He}}) = 33$ MeV: see (1986AJ01). For a discussion of $^{14}\text{N}^*(9.13)$ see (1986WA13). For work at very high energies see (1987AB1J). See also (1986SC35, 1990TO10; applied).

$$20. \text{}^{12}\text{C}(\alpha, d)\text{}^{14}\text{N} \qquad Q_m = -13.57434$$

Angular distributions of deuterons have been studied corresponding to the $T = 0$ states $^{14}\text{N}^*(0, 3.95, 4.92, 5.11, 5.69, 5.83, 7.97, 8.49, 8.96, 9.13, 9.39, 10.81)$ [$E_\alpha = 34.5, 42, 55$ MeV; not all states at all energies]. At the higher energies the deuteron spectrum is dominated by very strong

Table 14.16: Levels of ^{14}N from $^{13}\text{C}(p, \gamma)^{14}\text{N}$ and $^{13}\text{C}(p, p)^{13}\text{C}$ ^a

E_p (MeV \pm keV)	$\Gamma_{\text{c.m.}}$ (keV)	l_p	$\omega\Gamma_\gamma$ (eV)	$J^\pi; T$	$^{14}\text{N}^*$ (MeV)
0.4485 ± 0.5	< 0.37	2	0.022	2^-	7.9669
0.551 ± 1	23 ± 1 ^p	0	9.2	$1^-; 1$	8.062
1.012 ± 2	≤ 0.2	4	≈ 0.01	$(4^-); 0$	8.490
1.152 ± 2 ^b	3.8 ± 0.3	1	1.3	$0^+; 1$	8.620
1.320 ± 7 ^b	410 ± 20	0	12.8	$0^-; 1$	8.776
1.462 ± 3	16 ± 2	2	0.67 ± 0.07 ^e	$3^-; 1$	8.907
1.523 ± 2	< 1		≈ 0.003	$5^+; 0$	8.964
1.540 ± 3	8 ± 2	1, (3)	0.13	2^+	8.980
1.7005 ± 1 ^j	< 1			$3^+; 0$	9.1287
1.7476 ± 0.9 ^{c,j}	135 ± 8 eV		^c	$2^+; 1$	9.1724
1.980 ± 3	13 ± 3	2		$3^-, 2^-$	9.388
2.110 ± 3	41 ± 2	2	7.0 ± 1.0 ^o	$2^-; 1$	9.509
2.319 ± 4	15 ± 3	1	0.11 ± 0.01 ^o	1^+	9.703
2.743 ^d	12 ± 3	1	0.37 ± 0.03 ^o	$1^+, (2^+)$	10.096
2.885 ± 10 ^d	80 ± 15	0, 2		$1^{(-)}; 0$	10.228
3.105 ± 5 ^d	33 ± 3	1	22.8 ± 1.3 ^o	$2^+; 1$	10.432
3.20 ^d	140	0, 2		1^-	10.52
3.72 ± 30 ^f	165 ± 30				11.00
3.771 ± 5	1.2 ± 0.4		^k	3^+	11.050
3.79	100			1^+	11.07
3.94 ± 30	220 ± 30				11.21
3.98 ^d	11	2		3^-	11.24
4.04 ^d	175	2		2^-	11.30
4.14 ^d	28	1		1^+	11.39
4.525 ± 15 ^g	115 ± 10		^l	1^+	11.750
5.325 ± 10	48 ± 7		^m		12.492
5.88 ± 20 ^f	120 ± 30				13.01
6.20 ± 100 ^h	1000 ± 150		ⁿ	$(2^-); 1$	13.30
6.62 ± 20 ^f					13.69
ⁱ					

Table 14.16: Levels of ^{14}N from $^{13}\text{C}(p, \gamma)^{14}\text{N}$ and $^{13}\text{C}(p, p)^{13}\text{C}$ ^a (continued)

E_p (MeV \pm keV)	$\Gamma_{\text{c.m.}}$ (keV)	l_p	$\omega\Gamma_\gamma$ (eV)	$J^\pi; T$	$^{14}\text{N}^*$ (MeV)
16.1				$2^-; 1$	22.5
16.7				$2^-; 1$	23.0

^a See references in Tables 14.16 in (1970AJ04), 14.20 in (1976AJ04) and 14.16 in (1981AJ01).

^b See (1986AD01).

^c See (1981BI17): $E_x = 9172.5 \pm 0.3$ keV from γ -ray measurements. See also Table 14.10, $\Gamma_{\gamma_0}/\Gamma_\gamma = (79 \pm 4)\%$; Γ_{γ_0} (from reaction 41 and Table 14.19) = 7.2 ± 0.4 eV; $\Gamma_{\text{c.m.}}$ from $^{13}\text{C}(p, p)$.

^d Reduced width for proton emission is of the order of 1% of the Wigner limit. For recent work on the $E_p = 3.11$ MeV resonance see (1990WIZV; prelim.).

^e (1986ZI08); $\Gamma_{\gamma_0} = (11.0 \pm 1.7) \times 10^{-3}$ eV; see Table 14.11. See also (1985PR03).

^f Weak resonance.

^g In the $\gamma_{3.09}$ channel the peak occurs 55 keV higher: interference effects may be present.

^h Part of the giant dipole resonance.

ⁱ Some broad structures appear in the γ_0 , $\gamma_{3.68}$ and $\gamma_{3.85}$ yields. See also reaction 26 and reaction 25 in (1986AJ01).

^j See also (1986WA13) and Table 14.15.

^k $\Gamma_\gamma = 1.2 \pm 0.4$ keV; $\Gamma_p = 0.5\%$ of single-particle unit. J^π based on angular distribution of γ_0 . For nature of γ -decay see Table 14.11.

^l $(2J + 1) \Gamma_\gamma = (18.5 \pm 4.2) \Gamma/\Gamma_p$ eV; if $J = 1$, $\Gamma_\gamma \geq 6$ eV.

^m $(2J + 1) \Gamma_{\gamma_0} = 2.3 \Gamma/\Gamma_p$ eV, if $\Gamma = 38$ eV is assumed.

ⁿ $(2J + 1) \Gamma_{\gamma_0} \geq 200$ eV: thus the transition is dipole and $T = 1$. The resonance is asymmetric and it is suggested that two states are involved, one with $J^\pi = 1^-$ at $E_x = 12.7$ MeV and the other one with 2^- at $E_x = 13.3$ MeV.

^o (1985PR03).

^p (1990SP02).

groups corresponding to the $(d_{5/2})^2$, $J^\pi = 5^+$ state at 8.96 MeV, and to a state at 15.1 ± 0.1 MeV: see Table 14.19 in (1976AJ04), and (1981AJ01, 1986AJ01). At $E_\alpha = 50$ MeV the angular distributions of the singlet deuterons exciting the $T = 1$ states $^{14}\text{N}^*(2.31, 8.91[\text{u}])$ have been studied by (1986SA06): a state at 12.6 ± 0.3 MeV is also populated. See also (1989GA1H, 1989SH1G).

21. $^{12}\text{C}(^6\text{Li}, \alpha)^{14}\text{N}$

$$Q_m = 8.7974$$

At $E(^6\text{Li}) = 20$ MeV [see Table 14.19 in (1976AJ04)] and 32 MeV [see Table 14.13 here] many of the α -groups corresponding to $T = 0$ states with $E_x < 17.2$ MeV are observed. The 5^+

state, $^{14}\text{N}^*(9.0)$, is strongly populated: see (1970AJ04). Angular distributions have been measured at $E(^6\text{Li}) = 2$ to 33 MeV: see (1981AJ01, 1986AJ01). Inclusive α -particle spectra have been studied at $E(^6\text{Li}) = 156$ MeV (1989JE01). See also ^{18}F in (1987AJ02), (1987PA12) and (1986HA1E; theor.).

$$22. \ ^{12}\text{C}(^9\text{Be}, ^7\text{Li})^{14}\text{N} \quad Q_{\text{m}} = -6.4227$$

See (1988GO1H).

$$23. \ ^{12}\text{C}(^{12}\text{C}, ^{10}\text{B})^{14}\text{N} \quad Q_{\text{m}} = -14.9144$$

This reaction has been studied at $E(^{12}\text{C}) = 114$ MeV: the spectrum is dominated by $^{14}\text{N}^*(8.96)$ [$J^\pi = 5^+$] but there is substantial population also of $^{14}\text{N}^*(5.83)$ [3^-] and of a state at $E_{\text{x}} = 11.2$ MeV. Angular distributions are reported at $E(^{12}\text{C}) = 49.0$ to 93.8 MeV: see (1981AJ01, 1986AJ01).

$$24. \ ^{12}\text{C}(^{13}\text{C}, ^{11}\text{B})^{14}\text{N} \quad Q_{\text{m}} = -8.4066$$

At $E(^{13}\text{C}) = 390$ MeV angular distributions have been studied to $^{14}\text{N}^*(0, 2.31, 5.8[\text{u}])$ and to unresolved structures and continua. The spectra are dominated by the group to $^{14}\text{N}^*(5.8)$ (1987AD07, 1988VO08). See also (1989VO1D).

$$25. \ (a) \ ^{13}\text{C}(p, \gamma)^{14}\text{N} \quad Q_{\text{m}} = 7.55063$$

$$(b) \ ^{13}\text{C}(p, p'\gamma)^{13}\text{C} \quad E_{\text{b}} = 7.55063$$

Observed resonances are displayed in Table 14.16. The radiative decay is exhibited in Table 14.11.

The low-energy capture cross section yields an extrapolated S -factor at $E_{\text{p}} = 25$ keV (c.m.), $S_0 = 6.0 \pm 0.8$ keV \cdot b. The capture cross section rises from $(7.7 \pm 1.8) \times 10^{-10}$ b at $E_{\text{p}} = 100$ keV to $(9.8 \pm 1.2) \times 10^{-9}$ b at $E_{\text{p}} = 140$ keV: see (1970AJ04).

Following is a summary of the reasons for the assignments of J^π ; T to some of the lower resonances displayed in Table 14.16: for a fuller discussion and complete references see (1970AJ04, 1976AJ04, 1981AJ01). $^{14}\text{N}(7.97)$: angular distribution of the γ -rays is consistent with $J^\pi = 2^-$, $^{14}\text{N}^*(8.06)$: width of resonance, isotropy of γ -rays show $l_{\text{p}} = 0$; $J^\pi = 1^-$ from $^{13}\text{C}(p, p)$; E1 transition to g.s. is uninhibited; therefore, $T = 1$ [but 1.4% $8.06 \rightarrow 2.31$ transition [$E_{\text{x}} = 2312.6 \pm 0.3$ keV] shows $T = 0$ admixture: $\alpha^2 = 0.046$]. The strong transition $8.06 \rightarrow 5.69$ [3.5%] permits

either E1 or M1, $\Delta T = 1$. Since $5.69 \rightarrow 2.31$ is seen $^{14}\text{N}^*(5.69)$ cannot have $J^\pi = 0^+$, and 2^+ is excluded by the strength of the $8.62 \rightarrow 5.69$ transition. It is then $J^\pi = 1^-$; $T = 0$ [the isospin mixing $\alpha^2 = 0.09$]; $E_x = 5691.55 \pm 0.13$ keV (1981BI17). $^{14}\text{N}^*(8.49, 8.96, 9.13)$ correspond to anomalies in the cross section. The nature of their γ -decays [see Table 14.11] and the angular distribution leads to $J^\pi = 4^-, 5^+, 3^+$ [all $T = 0$], respectively.

$^{14}\text{N}^*(8.62)$ [$J^\pi = 0^+$ from $^{13}\text{C}(\text{p}, \text{p})$] shows strong transitions to $^{14}\text{N}^*(0, 3.95, 5.69)$: $T = 1$. The strength of the $8.62 \rightarrow 3.95$ decay shows it is dipole and therefore $J = 1$ for $^{14}\text{N}^*(3.95)$ [$E_x = 3947.6 \pm 0.4$ keV]. The strength of the transition $8.62 \rightarrow 6.20$ and the angular correlation $8.62 \rightarrow 6.20 \rightarrow \text{g.s.}$ is consistent with $J^\pi = 1^+$, $T = 0$ for $^{14}\text{N}^*(6.20)$ [$E_x = 6203.7 \pm 0.6$ keV]. $^{14}\text{N}^*(8.78)$ [$J^\pi = 0^-$ from $^{13}\text{C}(\text{p}, \text{p})$] has a large Γ_γ consistent with E1 and $T = 1$. $^{14}\text{N}^*(9.17)$: angular correlation and angular distribution measurements indicate $J^\pi = 2^+$ for that state, 3^- for $^{14}\text{N}^*(6.45)$ [see however Table 14.10] and $J = 2$ for $^{14}\text{N}^*(7.03)$. For recent studies of $^{14}\text{N}^*(9.17)$ see (1981BI17, 1986WA13): $E_x = 9172.5 \pm 0.3$ keV from E_γ , $\Gamma_{\gamma_0}/\Gamma_\gamma = (79 \pm 4)\%$, Γ [from (p, p)] = 135 ± 8 eV [135 ± 11 eV in (γ, γ)]. Other E_x determined by (1981BI17) are 2312.90 ± 0.03 , 3948.2 ± 0.2 , 5105.9 ± 0.3 , and 6446.3 ± 0.2 keV. See also Tables 14.11 and 14.15.

The angular distribution of the γ -rays from $10.23 \rightarrow 2.31$ is consistent with $J^\pi = 1^+$ for $^{14}\text{N}^*(10.23)$: $T = 0$ from M^2 (M1) [see, however, Table 14.10]. The γ_0 angular distribution is consistent with $J = 2$ for $^{14}\text{N}^*(10.43)$: the similar decay characteristics of this state and of $^{14}\text{N}^*(9.17)$ suggest that they are both $J^\pi = 2^+$, $T = 1$.

Below $E_p = 5.5$ MeV only γ_0 can be observed in the capture radiation. A number of resonances in the γ_0 yield and in the yield of the ground-state γ -rays from $^{13}\text{C}^*(3.09, 3.68, 3.85)$ have been observed: these are shown in Table 14.16 in the range $E_p = 3.7$ to 6.6 MeV. Angular distributions and measurements of Γ_{γ_0} lead to the J^π values shown. Above $E_p = 7$ MeV the γ_0 yield shows broad structure and the giant dipole resonance at $E_x = 22.5$ and 23.0 MeV. Measurements of the γ_0 and γ_1 90° yields for $E_x = 23$ to 33 MeV find that the $T = 2$ resonances reported earlier at $E_x = 23.7$ and 24.2 MeV do not exist and that there is no evidence for the $T = 2$ GDR between $E_x = 25$ and 29 MeV. The 90° yields of γ -rays to $T = 0$ states ($4.9 < E_x < 5.9$ MeV) and to $T = 1$ states ($8.0 < E_x < 9.5$ MeV) have been measured from $E_x = 23$ and 26 MeV, respectively, to $E_x = 33$ MeV. A study of the 90° yield of γ_0 and γ_1 [and of analyzing powers] has been reported for $E_p = 6.25$ to 17.0 MeV. The γ_0 results are in good agreement with those in the inverse reaction [$^{14}\text{N}(\gamma, \text{p})^{13}\text{C}$]. Broad structures are observed at $E_p \approx 8, 13, 14, 15$ and 16.5 MeV. The γ_1 results indicate that the $T = 0$ strength is spread out fairly uniformly between $E_x = 13$ and 23 MeV. At $E_p = 25$ MeV strong transitions are observed to two groups of states centered near $E_x = 5.8$ and 8.9 MeV.

For searches for short-lived neutral particles in the decay of $^{14}\text{N}^*(9.17)$ see (1986SA2E, 1988SA2A). See also (1985AB15), (1986RO18, 1988KI1C; applied), (1985CA41, 1987WE1C, 1988CA26, 1989BA2P, 1990MA1P; astrophysics) and (1986WE1D, 1987MC1C) and (1980HA30; theor.).

Table 14.17: Resonances in $^{13}\text{C}(p, n)^{13}\text{N}$ (1961DA09) ^a

E_p (MeV)	Γ (keV)	$^{14}\text{N}^*$ (MeV)
3.76 ± 0.05	100	11.04
3.98 ± 0.02	30	11.24
4.05		11.31
4.15 ± 0.02	40	11.40
4.5 ± 0.1	100	11.7
4.7 ± 0.1	150	11.9
5.03 ^b		12.22
(5.44 ± 0.03)	(60)	(12.60)
5.53 ± 0.03	50	12.68
5.72 ± 0.03	60	12.86
6.20 ± 0.04	70	13.30
6.67 ± 0.13 ^c	250	13.74
7.0 ± 0.1	150	14.0
7.3		14.3
7.85 ± 0.08	150	14.83
7.93 ± 0.03	50	14.91
8.03 ± 0.03	50	15.00
8.7 ± 0.2	350	15.6
9.3 ± 0.1	150	16.2
10.2 ± 0.2	400	17.0
11.4 ± 0.3	600	18.1

^a See also Table 14.9 in (1959AJ76).

^b (1959GI47).

^c See also (1989WA16).

The elastic scattering has been studied for $E_p = 0.14$ MeV to 1 GeV: see (1981AJ01) and ^{13}C here. For observed resonances see Table 14.16. A_y measurements have been reported at $E_{\bar{p}} = 200$ and 547 MeV [see (1986AJ01)], at 35 MeV (1986OH03; $p_{0\rightarrow 3}$), at 71.8 MeV (1989VO05, 1990VO02; p_0 ; and measurements of depolarization parameter, D), at 119 MeV (1988CO05; $p_0 \rightarrow p_4$ and p to $^{13}\text{C}^*(7.55, 8.86, 9.5, 9.9)$) and at 500 MeV (1990HO06; p_0 ; A_y and rotation parameters). See (1990HO1L; prelim.) for measurements at $E_p = 497.5$ MeV on $^{13}\vec{\text{C}}$. The $0^+ - 0^-$ doublet at $E_x \approx 8.7$ MeV has been studied by (1984AD04, 1986AD01, 1986SW1A, 1987ZEZZ, 1988ZE1B). For pion production see (1988HU06). See also (1985BL22, 1986ADZT) and (1986RA05, 1987BE1M, 1987BE1P, 1988RA08, 1989AM05, 1989BEXT, 1989GO14, 1989KU07, 1989KU14, 1989KU32, 1989RA10, 1990DU01; theor.).

$$27. \ ^{13}\text{C}(p, n)^{13}\text{N} \qquad Q_m = -3.0028 \qquad E_b = 7.55063$$

Observed resonances are displayed in Table 14.17. Polarization measurements are reported at $E_{\bar{p}} = 35$ MeV (1986OH03; A_y ; n_0, n_1, n_{2+3}) and 160 MeV (1984TA07, 1987RA15; A_y ; $D_{NN}(0^\circ)$; n_0, n_{2+3} , and n to $^{13}\text{N}^*(15.1)[u]$). Forward-angle cross sections have been measured at $E_p = 318$ and 800 MeV (1986KI12) and at 492 and 590 MeV (1989RA09). Cross sections for ^{13}N production have been studied for $E_p = 5.2$ to 30.6 MeV by (1989WA16). For the earlier work see (1986AJ01). See also ^{13}N , (1987ALZW, 1990TA1J), (1986AI04, 1989AR1Q; applied), (1985CA41; astrophysics), (1986AL18, 1986CA1N, 1986TA1E, 1987TA22) and (1987BE1D, 1989AM02, 1989RA15; theor.).

$$28. \ ^{13}\text{C}(p, d)^{12}\text{C} \qquad Q_m = -2.7218 \qquad E_b = 7.55063$$

A_y measurements have been reported at $E_{\bar{p}} = 13.6$ to 530 MeV [see (1986AJ01)] and at 119 MeV (1987LE24; to $^{12}\text{C}^*(0, 4.4, 7.7, 9.6, 12.7, 14.1, 15.1, 16.1, 16.6, 17.8, 18.1, 18.8, 19.9, 20.3, 20.6)$). For a measurement of the tensor polarization of $^{12}\text{C}^*(15.1)$ at $E_p = 41.3$ MeV see (1987CA20). For other work see (1976AJ04, 1981AJ01) and ^{12}C in (1990AJ01). See also (1986KO1K; theor.).

$$29. \ (a) \ ^{13}\text{C}(p, t)^{11}\text{C} \qquad Q_m = -15.1863 \qquad E_b = 7.55063$$

$$\quad (b) \ ^{13}\text{C}(p, ^3\text{He})^{11}\text{B} \qquad Q_m = -13.1855$$

See ^{11}B , ^{11}C in (1990AJ01), and (1986AJ01).

$$30. \ ^{13}\text{C}(p, \alpha)^{10}\text{B} \qquad Q_m = -4.0618 \qquad E_b = 7.55063$$

See (1981AJ01).

Table 14.18: ^{14}N levels from $^{13}\text{C}(\text{d}, \text{n})$ and $^{13}\text{C}(\text{}^3\text{He}, \text{d})$ ^a

$^{14}\text{N}^*$ ^b (MeV \pm keV)	$J^\pi; T$ ^b	l_p ^c	l_j ^d	$(2J_f + 1)C^2S$ ^d
0	$1^+; 0$	1	$p_{1/2}$	2.27
2.31	$0^+; 1$	1	$p_{1/2}$	0.92
3.95	$1^+; 0$	1	$p_{3/2}$	1.10
4.92	$0^-; 0$	0	$s_{1/2}$	0.29
5.11	$2^-; 0$	2	$d_{5/2}$	1.79
5.69	$1^-; 0$	0	$s_{1/2}$	0.91
			$d_{3/2}$	0.29
5.83	$3^-; 0$	2	$d_{5/2}$	2.19
6.20	$1^+; 0$	1	$p_{1/2}$	0.032
6.45	$3^+; 0$	1	$f_{7/2}$	(0.1)
7.03	$2^+; 0$	1	$p_{3/2}$	0.31
7.97	$2^-; 0$		$d_{5/2}$	0.051
8.06	$1^-; 1$	0	$s_{1/2}$	0.10
			$d_{3/2}$	< 0.006
8.49	$4^-; 0$	$4^{h, i}$		
8.62	$0^+; 1$	1^j	$p_{1/2}$	0.021
8.78	$0^-; 1$		$s_{1/2}$	< 0.009
8.91	$3^-; 1$	2^k	$d_{5/2}$	3.32
8.98	$2^+; (0)$	(1, 2, 3)	$p_{3/2}$	< 0.2
9.13	$(2^-; 0)^g$	2	$d_{5/2}$	0.14
9.17	$2^+; 1$	(1, 3)	$p_{3/2}$	< 0.08
9.39	$2^-; 0$	2	$d_{5/2}$	0.62
9.51	$2^-; 1$	2	$d_{5/2}$	1.31
9.70	$1^+; 0$	1	$p_{1/2}$	0.039
10.085 ± 12	$(1 - 3)^- e$		$d_{5/2}$	0.054
10.222 ± 12	$(0 - 2)^+ e$		$p_{1/2}$	0.16
10.534 ± 20	$(0 - 2)^+ e, f$		$p_{1/2}$	0.34
10.81	$5^+; 0^f$			
11.05	$(3^+)^{e, f}$			
11.26 ± 50	$(0 - 2)^+ e, f$		$p_{1/2}$	0.22

Table 14.18: ^{14}N levels from $^{13}\text{C}(\text{d}, \text{n})$ and $^{13}\text{C}(^3\text{He}, \text{d})$ ^a (continued)

$^{14}\text{N}^*$ ^b (MeV \pm keV)	J^π, T ^b	l_p ^c	l_j ^d	$(2J_f + 1)C^2S$ ^d
11.49 \pm 40	$(0 - 2)^+$ ^{e, f}		p _{3/2}	0.040
11.66 \pm 40	$(0 - 2)^+$ ^{e, f}		p _{1/2}	0.092

^a See also Table 14.18 in (1981AJ01) and 14.23 in (1976AJ04).

^b From Table 14.10.

^c $^{13}\text{C}(\text{d}, \text{n})^{14}\text{N}$: $E_d = 4.5$ to 6.5 MeV.

^d $^{13}\text{C}(^3\text{He}, \text{d})^{14}\text{N}$: $E(^3\text{He}) = 43.6$ MeV: see (1986AJ01).

^e From ($^3\text{He}, \text{d}$).

^f $\Gamma \approx 200, 50, 50, 80, 80$ and 100 keV for $^{14}\text{N}^*(10.53, 10.81, 11.06, 11.26, 11.51, 11.66)$.

^g See, however, Table 14.10.

^h Observed in (d, n) and ($^3\text{He}, \text{d}$).

ⁱ $\Gamma_p < 9.9 \times 10^{-2}$ eV.

^j $\Gamma_p < 18$ keV.

^k $\Gamma_p = 12.1$ keV.

$$31. \ ^{13}\text{C}(\text{d}, \text{n})^{14}\text{N} \quad Q_m = 5.3260$$

Observed neutron groups are displayed in Table 14.18. See (1970AJ04, 1976AJ04) for comments.

$$32. \ ^{13}\text{C}(^3\text{He}, \text{d})^{14}\text{N} \quad Q_m = 2.0571$$

Angular distributions have been reported at $E(^3\text{He}) = 33$ MeV to $^{14}\text{N}^*(0, 2.31, 3.95, 5.11, 5.83, 8.91, 9.51)$ (1986DR03; also A_y). See Table 14.18 here, and (1981AJ01), for the earlier work.

$$33. \ ^{13}\text{C}(\alpha, \text{t})^{14}\text{N} \quad Q_m = -12.2634$$

See (1981AJ01).

$$34. \ ^{13}\text{C}(^7\text{Li}, ^6\text{He})^{14}\text{N} \quad Q_m = -2.424$$

At $E(^7\text{Li}) = 34$ MeV angular distributions have been studied to $^{14}\text{N}^*(0, 2.31, 3.95, 5.0[\text{u}], 5.7[\text{u}])$. $^{14}\text{N}^*(7.0, 8.9, 9.5)$ are also populated. $^{14}\text{N}_{\text{g.s.}}$ is dominant (1987CO16). See also (1986AJ01), (1988AL1G) and reaction 18 in ^{14}C .

$$35. \ ^{14}\text{C}(\beta^-)^{14}\text{N} \quad Q_{\text{m}} = 0.15648$$

See ^{14}C . See also (1989AM01; theor.).

$$36. \ ^{14}\text{C}(\pi^+, \pi^0)^{14}\text{N} \quad Q_{\text{m}} = 4.761$$

Forward-angle differential cross sections for the isobaric-analog state (IAS) [$^{14}\text{N}^*(2.31)$] have been measured at $E_{\pi^+} = 20$ MeV (1987IR01), 35 to 80 MeV (1986UL01), 100 to 295 MeV (1983IR04) and 300 to 550 MeV (1988RO03). Angular distributions to the IAS are reported by (1986UL01, 1987IR01), See also (1985IR02, 1989LE1L) and (1989ST1H; theor.).

$$37. \ ^{14}\text{C}(\text{p}, \text{n})^{14}\text{N} \quad Q_{\text{m}} = -0.6259$$

Angular distributions, generally for the n_0 , n_1 and n_2 groups, have been measured in the range $E_{\text{p}} = 2.45$ to 45 MeV [see (1981AJ01, 1986AJ01)] and at $E_{\text{p}} = 35$ MeV (1990IE01) and 160 MeV (1987RA15). (1984TA07) have been measured the transverse spin-transfer coefficients [$D_{\text{NN}}(0^\circ)$] at 160 MeV for the groups to $^{14}\text{N}^*(0, 2.31 [D_{\text{NN}} = 1], 3.95, 13.72)$. The main GT strength lies in the three 1^+ states and their D_{NN} values, which are consistent with $\frac{1}{3}$, are those expected for pure $L = 0$ transitions (1984TA07). At $E_{\text{p}} = 60$ to 200 MeV the spectra are dominated by the neutrons to $^{14}\text{N}^*(3.95)$ (1987TA13). 0° differential cross sections have recently been obtained at $E_{\text{p}} = 60$ to 200 MeV (1987TA13; n_0, n_1, n_2), 200, 300, and 450 MeV (1989AL04; n_1, n_2) and 492 MeV (1989RA09). See also (1989MAZP). For discussions of the Fermi and Gamow-Teller strengths see (1985WA24, 1987RA15, 1987TA13, 1989RA09). See also ^{15}N , (1985TA23, 1989SU1J), (1988CA26, 1989KEZZ; astrophysics), (1986AL18, 1986TA1E, 1986VO1G, 1987BE25, 1987GO1V, 1987HE22, 1987RA32, 1988RO17, 1988WA1Q, 1989RA1G, 1989SU1A) and (1986PE1E, 1987LO13, 1987LO1D, 1989AM01; theor.).

$$38. \ ^{14}\text{C}(^3\text{He}, \text{t})^{14}\text{N} \quad Q_{\text{m}} = 0.1379$$

At $E(^3\text{He}) = 44.8$ MeV, triton groups are observed corresponding to all known levels of ^{14}N with $E_{\text{x}} < 7.1$ MeV. Triton groups were also seen to unresolved states with $E_{\text{x}} = 8.0 \rightarrow 9.5$ MeV, to $^{14}\text{N}^*(10.43)$ and to excited states with $E_{\text{x}} = 12.49 \pm 0.04, 12.83 \pm 0.05$ and 13.70 ± 0.04 MeV.

Angular distributions were obtained for nine of the triton groups and analyzed using a local two-body interaction with an arbitrary spin-isospin exchange mixture. Dominant $L = 0$ to $^{14}\text{N}^*(2.31, 3.95, 13.7)$, $L = 1$ to $^{14}\text{N}^*(5.11)$, $L = 2$ to $^{14}\text{N}^*(0, 7.03, 10.43)$ and $L = 3$ to $^{14}\text{N}^*(5.83)$ (1969BA06). Angular distributions have also been studied at $E(^3\text{He}) = 72$ MeV (1988DE34, 1988DE47, 1989ER05; t_0, t_1, t_2).

$$39. \ ^{14}\text{C}(^6\text{Li}, ^6\text{He})^{14}\text{N} \quad Q_m = -3.350$$

Angular distributions have been studied at $E(^6\text{Li}) = 34$ and 62 MeV [see (1986AJ01)], at 93 MeV (1986BR33, 1987DE02, 1988DE47, 1989DE34; to $^{14}\text{N}^*(0, 3.95)$) and at $84, 150$ and 210 MeV (1987WI09, 1986AN29, 1988AN06; to $^{14}\text{N}^*(0, 2.31, 3.95)$). $^{14}\text{N}^*(3.95)$ dominates the spectra: see e.g. (1987WI09). $^{14}\text{N}^*(5.11, 5.83, 6.20, 7.03, 8.49)$ are also populated (1980WH03, 1987WI09). For studies of the GT strength see (1980WH03, 1987WI09). See also (1987AU04, 1988AU1E, 1988GA1N, 1989AU1B) and (1986AJ01).

$$\begin{aligned} 40. \text{ (a) } & \ ^{14}\text{N}(\gamma, n)^{13}\text{N} & Q_m = -10.5535 \\ \text{ (b) } & \ ^{14}\text{N}(\gamma, p)^{13}\text{C} & Q_m = -7.55063 \\ \text{ (c) } & \ ^{14}\text{N}(\gamma, d)^{12}\text{C} & Q_m = -10.27239 \\ \text{ (d) } & \ ^{14}\text{N}(\gamma, \pi^+)^{14}\text{C} & Q_m = -139.725 \end{aligned}$$

The total absorption over the range $E_\gamma = 9$ to 31 MeV is dominated by a single peak at 22.5 MeV [estimated $\sigma \approx 29$ mb, $\Gamma \approx 2 - 3$ MeV] and appreciable strength extending beyond 30 MeV. The cross section cannot be accounted for solely by the (γ, n) and (γ, p_0) processes: particle-unstable excited states of ^{13}C , ^{13}N are involved. The combined (γ, n) and (γ, pn) cross section begins to rise rapidly above 18 MeV, reaches its maximum value of 15 mb at 23.3 MeV and exhibits structure at about $19, 20.5$ and 26 MeV. The main peak ($\Gamma \approx 3.5$ MeV: see (1970AJ04)) at 23.3 MeV appears to be split into two absorption levels: see (1981AJ01). Maxima reported in other experiments and “breaks” in the (γ, n) activation curve are listed in (1970AJ04). Most of the photon absorption in the giant resonance region forms $J^\pi = 2^-$ states in ^{14}N which decay by d-wave neutron emission to $^{13}\text{N}_{\text{g.s.}}$. Some evidence is found for the existence of $J^\pi = 0^-$ strength at the peak of the giant resonance and for a small amount of isospin $T = 0$ mixing near 22.5 MeV: see (1981AJ01). The cross section for the (γ, n) reaction has recently been measured from threshold to 15.5 MeV (1987FA14). See also (1988DI02).

The (γ, p_0) and (γ, p_2) cross sections and angular distributions have been measured in the giant resonance region. The giant dipole states $[(p_{3/2})^{-1} (2s1d)]$ which decay by p_0 emission to $^{13}\text{C}^*(3.68)$ appear to carry $\approx 90\%$ of the E1 strength and do not contribute substantially to the (γ, p_0) process which is populated by $(p_{1/2})^{-1} (2s1d)$ giant dipole states. Above $E_\gamma = 22$ MeV d-wave emission from 2^- states appears to dominate the (γ, p_0) cross section: see (1976AJ04).

For reaction (c) see (1987IM02). For reaction (d) see ^{14}C . See also (1985FU1C) and (1985GO1A, 1986WI10, 1987HU01, 1987KI1C, 1987LU1B, 1988DU04; theor.).

41. $^{14}\text{N}(\gamma, \gamma)^{14}\text{N}$

A measurement of the protons from the $^{14}\text{N}(\gamma, p)^{13}\text{C}$ reaction and a resonant absorption measurement lead to $\Gamma_{\gamma_0}/\Gamma = 0.052 \pm 0.004$ for $^{14}\text{N}^*(9.17)$ and to $\Gamma = 122 \pm 8$ eV (1989VA21). See also (1986AJ01), Table 14.19, (1985BEZI, 1987BE1K) and (1986DU03; theor.).

42. (a) $^{14}\text{N}(e, e)^{14}\text{N}$

(b) $^{14}\text{N}(e, ep)^{13}\text{C} \quad Q_m = -7.55063$

Form factors have been determined at many energies in the range $E_e = 60.7$ to 300 MeV: see (1981AJ01, 1986AJ01) for the earlier references. In recent work at $E_e = 80.0$ to 372.6 MeV the form factors for $^{14}\text{N}^*(0, 2.31)$ have been determined [$q = 0.80$ to 3.55 fm^{-1}] (1987HU01; see for a discussion of the wave functions for these two states): see also (1989AM01, 1989TA01). A number of other excited states of ^{14}N have also been studied: see Table 14.19. (1984BE13) have populated $^{14}\text{N}^*(12.50, 13.17, 13.71, 15.43, 15.7, 17.2, 17.8)$ but not the 5^- states at $E_x = 14.66$ and 17.46 MeV which are thus presumably $T = 0$. (1984BE13) report that within the triplet of 5^- states at 14.66, 16.91, 17.46 MeV, they can account for $\approx 60\%$ of the isovector 5^- strength but only 35% of the isoscalar strength. There is no other significant M4 strength up to $E_x \approx 28$ MeV (1984BE13).

See also (1986LI1C, 1987DE43, 1987LI30, 1987RO23) and (1985CH1F, 1985CH1G, 1985GO1P, 1986DO11, 1986ER1A, 1986GO29, 1986JE1B, 1986ZE1A, 1987GO08, 1988AL1J, 1988GO1R, 1988YA10, 1990BE24, 1990GA1M; theor.).

43. $^{14}\text{N}(\pi^\pm, \pi^\pm)^{14}\text{N}$

Angular distributions at $E_{\pi^\pm} = 162$ MeV have been studied to the states listed in Table 14.20 (1983GE03). See also the “General” section.

44. $^{14}\text{N}(n, n)^{14}\text{N}$

Angular distributions of elastically and inelastically scattered neutrons are displayed in Table 14.23 of (1970AJ04). Recent work is reported at $E_n = 7.68$ to 13.50 MeV (1986CH2F; prelim.; to $^{14}\text{N}^*(0, 2.31, 3.95, 4.91, 5.11, 5.69, 5.83)$), 11, 14 and 17 MeV (1985TE01; n_0 ; prelim.), 20 and 25

Table 14.19: ^{14}N states from $^{14}\text{N}(\gamma, \gamma')$ and $^{14}\text{N}(e, e')$ ^a

E_x (MeV \pm keV)	Mult.	$J^\pi; T$	Γ_{γ_0} (eV)	Γ (keV)
8.06	E1	$1^-; 1$	10.5 ± 6	
8.91	M2	$3^-; 1$	$(6.6 \pm 2.2) \times 10^{-3}$	
9.17	M1	$2^+; 1$	7.2 ± 0.4 ^b	
			$\underline{6.3 \pm 0.3}$ ^c	
10.43 ^d	M1	$2^+; 1$	9.6 ± 1.9 ^e	
11.24 ^f	C3	(3^-)		
12.54 ± 100 ^e	(M1, C2)	$J = 0, 1, 2, 3$	$\underline{14.7 \pm 3.2}$ $2J + 1$	
12.81 ^f	C3	4^-		
13.27 ± 100 ^e	(M1, M2, C2)	$J = 0, 1, 2, 3$		
13.76 ± 100 ^e	(M1, C1)	$J = 0, 1, 2$	$(4 \pm 1) \times 10^{-3}$ ^g	
14.72 ± 30 ^f	M2	$(2^-; 1)$		≈ 100
15.01 ± 30 ^f	M4	$3^-, 4^-; \approx 1$		≈ 100
16.11 ± 100 ^e	(M2)	$J = 0, 1, 2, 3$		
16.91 ± 20 ^f	M4	$5^-; \approx 1$		170 ± 20
18.48 ± 40 ^f	M4	$5^-; \approx 1$		
20.11 ± 20 ^f	M4	$3^-, 4^-; \approx 1$		120 ± 20

^a See Table 14.19 in (1981AJ01) for references and additional information. See also Table 14.11 here.

^b (1981BI17).

^c A. Richter and G. Kuehner, private communication; adopted.

^d $\Gamma = 44$ keV, $\Gamma_{\gamma_0} = 8.8$ eV (A. Richter and G. Kuehner, private communication).

^e (1979EN01).

^f (1984BE13).

^g And $\Gamma = 105 \pm 20$ keV (A. Richter and G. Kuehner, private communication).

Table 14.20: States of ^{14}N from $^{14}\text{N}(\pi^\pm, \pi^\pm)$ (1983GE03)

E_x (MeV)	$J^\pi; T$	Mult.	$B(E\lambda)$ ($e^2 \cdot \text{fm}^{2\lambda}$)
0			
3.95		E2	2.8 ± 0.4
4.92			
5.11		E3	74 ± 10
5.69			
5.83		E3	117 ± 18
7.03		E2	3.95 ± 0.7
8.49			
11.24		E3	110 ± 12
12.79		E3	151 ± 17
13.14		E3	31 ± 8^b
14.66	$5^-; 0 + 1$		
15.10			
15.57	$2, 3, 4^-; 0$	E3	$10(2J + 1)$
16.06	$3^-; 0$		
16.86	$5^-; 1 + 0$		
17.46	$5^-; 0 + 1$		
17.89	$2^- + 4^-; 0$		
^a			
18.70	$(3^-); 0 + 1$		
20.10	$(3^-); 0 + 1$		

^a States at $E_x = 18.2$ and 18.4 MeV are also populated.

^b $J^\pi = 2^-$ assumed.

MeV (1985PE10; n_0) and at 21.6 MeV (1990OL01; n to $^{14}\text{N}^*(0, 5.83, 7.03)$ as well as at $E_{\bar{n}} = 10, 12, 14$ and 17 MeV (1986LI1M; n_0 ; prelim.). See also (1976AJ04), (1986GEZX, 1989LI26) and (1989STZW; applied).

45. (a) $^{14}\text{N}(p, p)^{14}\text{N}$
 (b) $^{14}\text{N}(p, 2p)^{13}\text{C}$ $Q_m = -7.55063$
 (c) $^{14}\text{N}(p, pd)^{12}\text{C}$ $Q_m = -10.27239$
 (d) $^{14}\text{N}(p, p\alpha)^{10}\text{B}$ $Q_m = -11.6125$

Angular distributions of elastically and inelastically scattered protons have been studied at many energies up to $E_p = 800$ MeV [see (1981AJ01, 1986AJ01)], at $E_{\bar{p}} = 35$ MeV (1990IE01; p_1) and 800 MeV (1985BL22; elastic) and at $E_p = 1$ GeV (1985AL16; elastic). For a display of the observed ^{14}N states see Table 14.24 in (1986AJ01). For a study of the 1.6 and 2.3 MeV γ -rays [from $^{14}\text{N}^*(2.31, 3.95)$] see (1988LE08). For reaction (b) see (1989BE1P) and ^{13}C . For reaction (c) see (1985DE17). For reaction (d) see ^{10}B (1988AJ01). See also (1989BEXX), (1985PE10, 1987VD1A) and (1986AO1A, 1986ER1A, 1987HU01, 1987VD03, 1988VD1B, 1989AM01, 1989LO1E; theor.).

46. $^{14}\text{N}(d, d)^{14}\text{N}$

Angular distributions of elastically and inelastically scattered deuterons have been studied to $E_d = 52$ MeV: see Table 14.20 in (1981AJ01). The deuteron group to the $0^+, T = 1$ state $^{14}\text{N}^*(2.31)$ is isospin “forbidden”: its cross section is 1-2 orders of magnitude less than that to $^{14}\text{N}^*(3.95)$ [$J^\pi; T = 1^+; 0$]: see (1981AJ01). See also (1986HA1E, 1986AO1A; theor.).

47. $^{14}\text{N}(^3\text{He}, ^3\text{He})^{14}\text{N}$

Angular distributions of elastically and inelastically scattered ^3He ions have been measured at $E(^3\text{He})$ up to 44.6 MeV: see Table 14.20 in (1981AJ01). See also (1989DE1Q).

48. $^{14}\text{N}(\alpha, \alpha)^{14}\text{N}$

Angular distributions of elastically and inelastically scattered α -particles have been studied for $E_\alpha = 7.6$ to 104 MeV [see Table 14.24 in (1986AJ01)] and at $E_\alpha = 48.7$ and 54.1 MeV (1987AB03; α_0). See also ^{18}F in (1987AJ02), (1987BU27, 1989BE1R), (1989GU28; astrophysics), (1988PA1K; applied) and (1985SH1D; theor.).

49. (a) $^{14}\text{N}(^6\text{Li}, ^6\text{Li})^{14}\text{N}$
 (b) $^{14}\text{N}(^7\text{Li}, ^7\text{Li})^{14}\text{N}$

Elastic angular distributions have been measured at $E(^6\text{Li}) = 19.5, 32$ and 36 MeV and at $E(^7\text{Li}) = 36$ MeV: see (1981AJ01, 1986AJ01). For reaction (b) see also (1986GO1H; $E(^{14}\text{N}) = 150$ MeV; prelim.). See also (1989DE1Q).

50. $^{14}\text{N}(^9\text{Be}, ^9\text{Be})^{14}\text{N}$

See (1986AJ01) and (1988HAZS).

51. (a) $^{14}\text{N}(^{10}\text{B}, ^{10}\text{B})^{14}\text{N}$
 (b) $^{14}\text{N}(^{11}\text{B}, ^{11}\text{B})^{14}\text{N}$

Elastic angular distributions have been measured for reaction (a) at $E(^{10}\text{B}) = 100$ MeV and $E(^{14}\text{N}) = 73.9$ to 93.6 MeV [see (1981AJ01, 1986AJ01)] as well as at $E(^{14}\text{N}) = 38.1, 42.0, 46.0$ and 50.0 MeV (1988TA13); those for reaction (b) have been studied at $E(^{14}\text{N}) = 41, 77$ and 113 MeV: see (1981AJ01). For fusion and other yield measurements see (1986AJ01). See also (1985BE1A, 1985CU1A) and (1985KO1J, 1986RO12; theor.).

52. (a) $^{14}\text{N}(^{12}\text{C}, ^{12}\text{C})^{14}\text{N}$
 (b) $^{14}\text{N}(^{12}\text{C}, \text{d}^{12}\text{C})^{12}\text{C}$ $Q_m = -10.27239$

Elastic and inelastic angular distributions have been studied in the range $E(^{14}\text{N}) = 21.3$ to 155 MeV [see (1981AJ01)] and at 86 MeV (1988AR23). For cross sections and fusion, fragmentation and evaporation residue studies see (1981AJ01, 1986AJ01) and (1986MO13, 1987GO1F, 1987ST01, 1989KI13, 1990WE14). For high-energy γ -emission see (1986ST07). For neutron emission see (1988KI06). For pion emission see (1989SUZS). For reaction (b) see (1987AR25). See also (1986GO1H, 1987VE1D, 1988HAZS, 1989AR1M), (1982BA1D, 1985BA1T; astro-phys.), (1985BE1A, 1985CU1A, 1987GE1B) and (1985HU04, 1985KO1J, 1985VI09, 1986BA62, 1986HA13, 1986POZW, 1986RE14, 1987BI20, 1987RE03, 1987RE11, 1988BA37, 1988HE12, 1988PR02, 1989BL1D, 1989NI1C, 1989RO22, 1989SH05, 1990CA1S, 1990DE13, 1990GH1F, 1990PR01; theor.).

53. $^{14}\text{N}(^{13}\text{C}, ^{13}\text{C})^{14}\text{N}$

Elastic angular distributions have been measured at $E(^{14}\text{N}) = 19.3$ to 35 MeV and $E(^{13}\text{C}) = 105$ MeV: see (1981AJ01, 1986AJ01) [see also for fusion studies].

54. $^{14}\text{N}(^{14}\text{N}, ^{14}\text{N})^{14}\text{N}$

Elastic angular distributions have been studied for $E(^{14}\text{N}) = 5.0$ to 20.2 MeV: see (1981AJ01). For fusion and other cross section measurements, see (1981AJ01, 1986AJ01). See also (1985BE1A, 1985CU1A, 1986ST1J, 1986ST1A, 1988BO46) and (1985KO1J, 1986RO12; theor.).

55. (a) $^{14}\text{N}(^{16}\text{O}, ^{16}\text{O})^{14}\text{N}$
(b) $^{14}\text{N}(^{19}\text{F}, ^{19}\text{F})^{14}\text{N}$

Elastic angular distributions have been studied for $E(^{14}\text{N}) = 8.1$ to 155 MeV [reaction (a)]: see (1981AJ01). For fusion cross section measurements, see (1981AJ01, 1986AJ01). See also (1985BE1A, 1985CU1A) and (1985HU04, 1985KO1J; theor.). For reaction (b), see (1989HO1H; theor.).

56. (a) $^{14}\text{N}(^{24}\text{Mg}, ^{24}\text{Mg})^{14}\text{N}$
(b) $^{14}\text{N}(^{26}\text{Mg}, ^{26}\text{Mg})^{14}\text{N}$
(c) $^{14}\text{N}(^{27}\text{Al}, ^{27}\text{Al})^{14}\text{N}$
(d) $^{14}\text{N}(^{28}\text{Si}, ^{28}\text{Si})^{14}\text{N}$
(e) $^{14}\text{N}(^{40}\text{Ca}, ^{40}\text{Ca})^{14}\text{N}$
(f) $^{14}\text{N}(^{48}\text{Ca}, ^{48}\text{Ca})^{14}\text{N}$

Elastic angular distributions have been measured at $E(^{14}\text{N}) \approx 53$ MeV for reactions (a), (c) and (d) [see (1986AJ01)] and at 84 MeV (1988YA06; reaction (d); also inelastic to $^{28}\text{Si}^*(1.78)$). For fusion and fragmentation studies see (1986AJ01) and (1986SH25, 1987BE55, 1987GU1M, 1987ST01, 1987YI1A, 1988SH03, 1989BR1K, 1990GOZZ). For reaction (e), see also (1988GO12). For pion production [reaction (c)], see (1986ST03). See also (1987SH1A), (1987BL1D) and (1985BL17, 1985CE11, 1985ST20, 1986OS05, 1986POZW, 1986PR01, 1988AY03, 1989BH03, 1989CH1K; theor.).

57. $^{14}\text{O}(\beta^+)^{14}\text{N}$

$$Q_m = 5.1431$$

$^{14}\text{O}_{\text{g.s.}}$ decays predominantly to its analog state $^{14}\text{N}^*(2.31)$: $E_x = 2312.798 \pm 0.011$ keV (1982WA16): see reaction 1 in ^{14}O . See also (1989AM01; theor.).

58. $^{15}\text{N}(\gamma, n)^{14}\text{N}$ $Q_m = -10.8333$

See (1988MC01) in ^{15}N . See also (1981AJ01) and (1988GOZM; theor.).

59. $^{15}\text{N}(p, d)^{14}\text{N}$ $Q_m = -8.6087$

Angular distributions have been obtained at $E_p = 39.8$ MeV for the deuterons corresponding to $^{14}\text{N}^*(0 \rightarrow 8.06, 8.62, 8.91, 8.96 + 8.98, 9.17, 9.39, 9.51, 9.70, 10.10, 10.21, 10.43, 11.06, 11.23+11.30, 11.39, 11.51, 11.66, 11.74+11.80, 11.97, 12.21+12.29, 12.52, 12.61, 12.80+12.83, 13.17+13.23, 13.72)$. Spectroscopic factors were extracted by DWBA analysis of the $l_n = 1$ pickup angular distributions: see (1969SN04). See also (1970AJ04).

60. $^{15}\text{N}(d, t)^{14}\text{N}$ $Q_m = -4.5760$

At $E_d = 89.1$ MeV (1989SA13) have investigated the level structure of ^{14}N up to $E_x = 24$ MeV: see Table 14.21. Above $E_x = 18.6$ MeV no discrete states appear. The observed summed spectroscopic strength is 88% of the shell-model sum rule. No significant $l = 3$ strength was seen (1989SA13).

61. $^{15}\text{N}(^3\text{He}, \alpha)^{14}\text{N}$ $Q_m = 9.7445$

Observed states in ^{14}N are displayed in Table 14.28 of (1976AJ04) together with the derived spectroscopic factors. Recently, angular distributions and A_y have been determined at $E(^3\text{He}) = 33$ MeV to $^{14}\text{N}^*(0, 2.31, 3.95, 5.11, 5.83, 7.03, 9.17, 10.43, 12.5, 13.7)$ (1986DR03).

62. $^{15}\text{N}(^{13}\text{C}, ^{14}\text{C})^{14}\text{N}$ $Q_m = -2.6568$

See (1981AJ01).

63. $^{16}\text{O}(\pi^+, 2p)^{14}\text{N}$ $Q_m = 117.390$

Table 14.21: States of ^{14}N from $^{15}\text{N}(\text{d}, \text{t})^{14}\text{N}$ ^a (1989SA13)

E_x (MeV \pm keV)	l	$J^\pi; T$ ^b	j	C^2S ^c
0	1		$\frac{1}{2}$	1.24 ± 0.09
			$\frac{3}{2}$	0.10 ± 0.08
2.312 ± 2	1		$\frac{1}{2}$	0.472 ± 0.009
3.946 ± 4	1		$\frac{1}{2}$	0.18 ± 0.04
			$\frac{3}{2}$	0.48 ± 0.04
4.910 ± 6	(0)		$\frac{1}{2}$	(0.008 ± 0.001)
5.102 ± 5	2			0.056 ± 0.007
5.689 ± 4	2		$\frac{3}{2}$	0.010 ± 0.001
5.832 ± 3	2		$\frac{5}{2}$	0.045 ± 0.012
6.202 ± 3	1		$\frac{3}{2}$	0.047 ± 0.007
6.443 ± 6	?			$< (0.002)$
7.028 ± 2	1		$\frac{3}{2}$	1.11 ± 0.03
7.966 ± 4	(2)			(0.017 ± 0.005)
8.491 ± 4	?			
9.173 ± 5	1		$\frac{3}{2}$	0.423 ± 0.008
9.388 ± 5	(2)			(0.022 ± 0.003)
9.522 ± 21	(2)			(0.007 ± 0.001)
9.708 ± 8	1		($\frac{3}{2}$)	(0.005 ± 0.001)
10.108 ± 6	1	(2^+)	$\frac{3}{2}$	(0.061 ± 0.003)
10.440 ± 6	1		$\frac{3}{2}$	0.388 ± 0.013
11.056 ± 8	?			$< (0.017)$
11.252 ± 9	(2)		$\frac{5}{2}$	(0.016 ± 0.001)
11.515 ± 10	?	(3^+)		$< (0.006)$
11.754 ± 11	2		$\frac{3}{2}$	(0.014 ± 0.001)
12.505 ± 10	1	($1^+; 1$)	$\frac{3}{2}$	0.13 ± 0.01
12.812 ± 13	?			
13.186 ± 21	?			$< (0.015)$
13.732 ± 16	1		$\frac{3}{2}$	0.45 ± 0.01
14.57 ± 23	?			
14.90 ± 21	(2)		($\frac{5}{2}$)	(0.025 ± 0.002)

Table 14.21: States of ^{14}N from $^{15}\text{N}(\text{d}, \text{t})^{14}\text{N}$ ^a (1989SA13) (continued)

E_x (MeV \pm keV)	l	$J^\pi; T$ ^b	j	C^2S ^c
15.63 ± 70	(2)		$(\frac{5}{2})$	(0.037 ± 0.003)
16.15 ± 130	?			
16.99 ± 21	(2)		$(\frac{5}{2})$	(0.034 ± 0.003)
17.28 ± 40	?			$< (0.017)$
17.88 ± 30	(2)	(3^-)	$(\frac{5}{2})$	(0.045 ± 0.005)
18.51 ± 30	1	$(2^+; 1)$	$\frac{3}{2}$	0.043 ± 0.007

^a $E_d = 89$ MeV. Measured angular distributions and A_y ; FRDWBA.

^b Only those $J^\pi; T$ determined in this experiment are shown.

^c Errors shown refer only to statistics.

At $E_{\pi^+} = 116$ MeV proton angular correlations, energy sharing and recoil momentum distributions have been studied to groups corresponding to $^{14}\text{N}^*(0, 3.9[\text{u}], 7.0[\text{u}], 11.0[\text{u}])$. No evidence is seen for other narrow states. The upper limit for the excitation of $^{14}\text{N}^*(2.31) [0^+; T = 1]$ is 5% (1988SC14). See also (1990SC10) and (1989CH04; theor.). Work at $E_{\pi^+} = 165$ MeV suggests that the earlier work reports too low a cross section and underestimates the two-nucleon absorption mechanism (1990HY01). In this paper the fraction of the total absorption cross section which can be attributed to that mechanism is reported to be about 50% (1990HY01). See also (1988KY1A, 1988RO1M).

$$64. \text{ (a) } ^{16}\text{O}(\text{p}, ^3\text{He})^{14}\text{N} \quad Q_m = -15.2428$$

$$\text{ (b) } ^{16}\text{O}(\text{p}, \text{pd})^{14}\text{N} \quad Q_m = -20.7363$$

Angular distributions (reaction (a)) have been measured in the range $E_p = 27$ to 54.1 MeV: see (1981AJ01). Comparisons have been made of the ratio of (p, ^3He) to the $T = 1$ state at 2.31 MeV and of (p, t) to the analog $^{14}\text{O}_{\text{g.s.}}$: see ^{17}F in (1982AJ01). For cross sections for the production of γ -rays from the decay of $^{14}\text{N}^*(2.31, 5.11)$ at $E_p = 40, 65$ and 85 MeV see (1987LA11). For reaction (b) see (1986VDZY, 1987VD1A) and (1986GO28; theor.).

$$65. ^{16}\text{O}(\text{d}, \alpha)^{14}\text{N} \quad Q_m = 3.1104$$

Angular distributions have been measured at many energies up to $E_d = 40$ MeV: see (1981AJ01). The yield of the isospin forbidden α_1 group [to $^{14}\text{N}^*(2.31)$] has been studied for $E_d = 2$ to 15

MeV: the intensity of the group is strongly dependent on E_d and on the angle of observation. The α_1 reaction appears to proceed almost exclusively by a compound-nuclear process and its study leads to the determination of a large number of ^{18}F states: the average isospin impurity in ^{18}F for $10 \leq E_x \leq 20$ MeV is 3–10%. At $E_d = 50$ MeV, the intensity of ^{14}N (2.31) is 0.1–0.2% that of $^{14}\text{N}_{g.s.}$. See also ^{18}F in (1987AJ02), (1985KA1A), (1985HA38, 1986DU1K; applied) and (1986SI1D; computer).

$$66. \ ^{17}\text{O}(p, \alpha)^{14}\text{N} \quad Q_m = 1.1916$$

See (1988CA26; astrophys.).

¹⁴O
(Figs. 4 and 5)

GENERAL (See also (1986AJ01)).

Nuclear models: (1985BA75, 1987BL15).

Electromagnetic transitions: (1989RA16, 1989SP01).

Astrophysical questions: (1985TA1A, 1987RA1D).

Applied work: (1989AR1J).

Complex reactions involving ¹⁴O: (1987PE1C, 1988ST1D, 1989BA92, 1989DR03, 1989KI13).

Reactions involving pions (See also reactions 5 and 7.): (1986BA1C, 1986BO1N, 1986FO06, 1986GE06, 1986SI11, 1987BL15, 1987KA39, 1987KO1O, 1987KO1Q, 1987MI02, 1987PA1H, 1988AU1D, 1988HA37, 1988YU04, 1990HAZV).

Hypernuclei: (1989BA93).

Other topics: (1985AN28, 1986AN07).

Ground state of ¹⁴O: (1985AN28, 1986HE26, 1987SA15, 1988WRZZ).

For searches for ⁴n and ⁴H involving the production of ¹⁴O see (1986BE35, 1986BE54, 1988BE02).

1. ¹⁴O(β^+)¹⁴N $Q_m = 5.1431$

The best value of $\tau_{1/2} = 70.606 \pm 0.018$ s: see (1978WI04). See also (1976AJ04). ¹⁴O decays predominantly to its analog state ¹⁴N*(2.31) [J^π ; $T = 0^+$; 1; $E_x = 2312.798$ (11) keV, $E_\gamma = 2312.593$ (11) keV (1982WA16)]. The branching ratio to the state is $(99.336 \pm 0.010)\%$. This value is obtained by adopting $(0.61 \pm 0.01)\%$ and $(0.054 \pm 0.002)\%$ for the branching ratios to ¹⁴N*(0, 3.95) [both 1^+ ; 0 states]. $\log f^R t = 3.4892$ (2) for the $0^+ \rightarrow 0^+$ transition (1981WH03), using the Wapstra masses for the atomic mass excess of ¹⁴N, ¹H and n; E_{thresh} for the ¹⁴N (p, n) threshold (1981WH03) and E_x shown above for ¹⁴N*(2.31) (1982WA16). See (1989OR01, 1989OR09) for other calculations of $\log ft$ [3.4884 (5)] and comments. Critical surveys of superallowed Fermi transitions lead to values for the first row of the Kobayashi-Maskawa matrix = 0.9970 ± 0.0021 (1990HA13), 0.9989 ± 0.0012 (1990WI05, 1990WI10, 1990WI1J) [and D.H. Wilkinson, private communication].

For the transitions to ¹⁴N*(0, 3.95) $\log ft = 7.266 \pm 0.009$ (1980WI13) and 3.15 ± 0.02 , respectively. The Q -value difference between the $0^+ - 0^+$ transition in this decay and in the ^{26m}Al decay has been measured by (1987KO34). For a study of the longitudinal polarization of the positrons see (1988GI02, 1989CA1J, 1990CA1U). See also (1989HA1X, 1990HA1Q) and (1986IS07, 1986JA07, 1986SI1H, 1987JA07, 1988LO01, 1989SA1P, 1989WO1E; theor.).

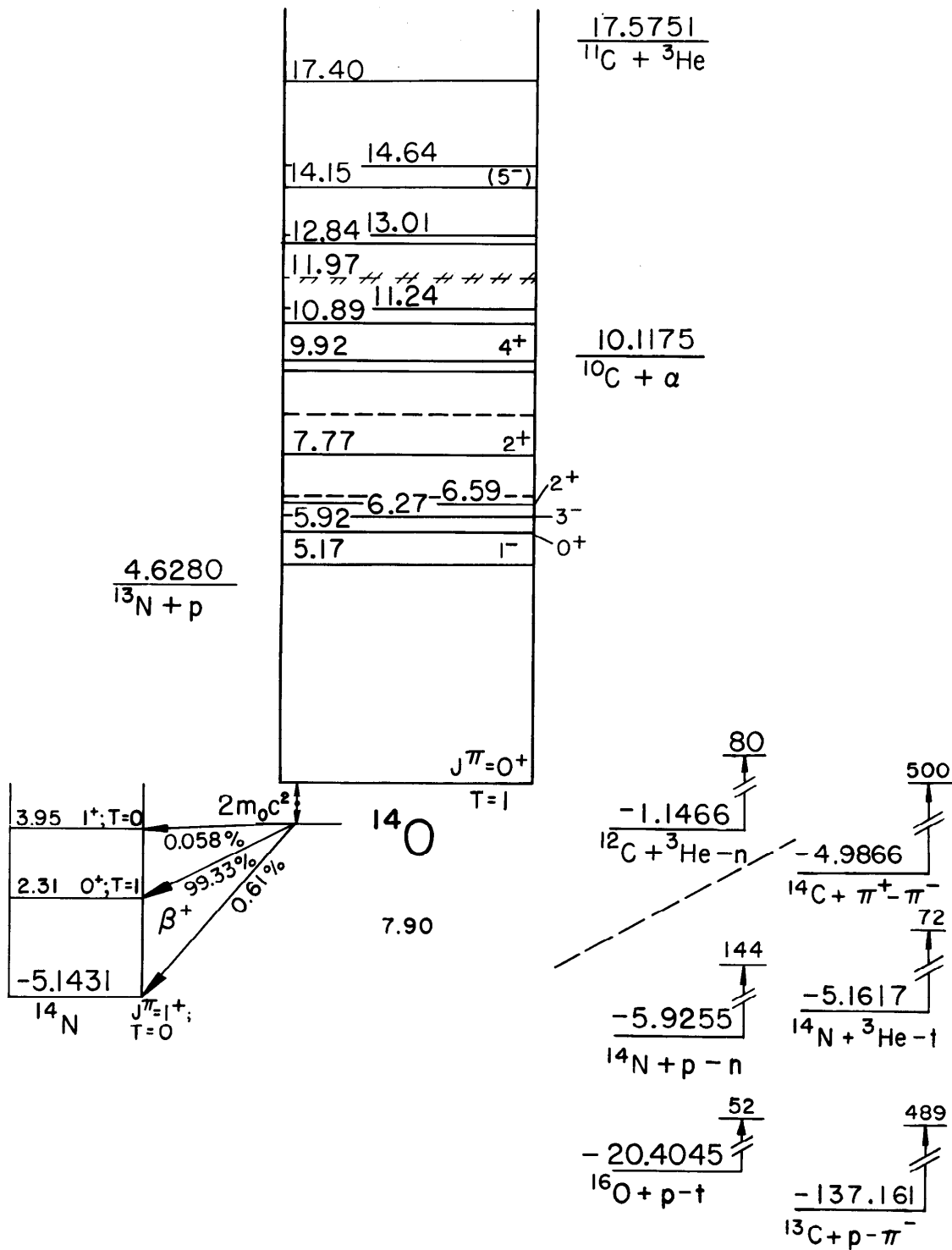

Figure 4: Energy levels of ^{14}O . For notation see Fig. 2.

Table 14.22: Energy levels of ^{14}O

E_x (MeV \pm keV)	$J^\pi; T$	$\tau_{1/2}$ or $\Gamma_{\text{c.m.}}$ (s) (keV)	Decay	Reactions
g.s.	$0^+; 1$	$\tau_{1/2} = 70.606 \pm 0.018$ s	β^+	1, 2, 3, 4, 5, 7, 8, 9, 10
5.173 ± 10	$1^-; 1$	$\Gamma = 38.1 \pm 1.8$ keV		3, 5, 6, 8, 9, 10
5.920 ± 10	$0^+; 1$	≤ 50	p	3, 9, 10
6.272 ± 10	$3^-; 1$	103 ± 6	p	3, 4, 5, 9, 10
6.590 ± 10	$2^+; 1$	≤ 60	p	3, 4, 5, 9, 10
(6.79 ± 30)	$\pi = -$			5, 9
7.768 ± 10	$2^+; 1$	76 ± 10	p	3, 5, 8, 9, 10
(8.72 ± 40)				9, 10
9.715 ± 20	$(2^+); 1$			3, 5, 10
9.915 ± 20	$4^+; 1$	100 ± 50		3, 4, 5, 9
10.89 ± 50				5, 9
11.24 ± 50				9
11.97^{a}				5, 9
12.84 ± 50				9
13.01 ± 50				9
14.15 ± 40	(5^-)			4, 5, 9
14.64 ± 60				5, 9
17.40 ± 60				5, 9

^a Possibly more than one level.

2. (a) ${}^9\text{Be}({}^{13}\text{C}, {}^8\text{He}){}^{14}\text{O}$ $Q_{\text{m}} = -25.13$

(b) ${}^9\text{Be}({}^{14}\text{C}, {}^9\text{He}){}^{14}\text{O}$ $Q_{\text{m}} = -34.44$

For reaction (a) see (1988BO20). For reaction (b) see (1988BEYJ).

3. ${}^{12}\text{C}({}^3\text{He}, \text{n}){}^{14}\text{O}$ $Q_{\text{m}} = -1.1466$

Observed neutron groups are displayed in Table 14.23. Angular distributions have been measured at $E({}^3\text{He}) = 15$ to 25.4 MeV [see (1981AJ01)] and at 45.5 MeV (1987AB04; n_0, n_1). For

Table 14.23: Levels of ^{14}O from $^{12}\text{C}(^3\text{He}, n)^{14}\text{O}$ ^a

E_x (MeV \pm keV)	$\Gamma_{\text{c.m.}}$ (keV)	L ^b	J^π ^b
0		0	0^+
5.173 ± 10		1	1^-
5.930 ± 15 ^c	≤ 47	0	0^+
6.272 ± 10	103 ± 6	3	3^-
6.596 ± 10 ^d	≤ 56	(2)	2^+ ^e
7.768 ± 10	76 ± 10	2	2^+
9.705 ± 25		(2)	(2^+)
9.915 ± 20 ^b	100 ± 50	4	4^+

^a For references see Table 14.22 in (1981AJ01).

^b See Table 14.30 in (1976AJ04).

^c $E_x = 5905 \pm 12$ keV has also been reported.

^d 6585 ± 5 keV has also been reported.

^e $J = 2$ follows from an np coincidence study. The J shown for $^{14}\text{O}^*(5.92, 6.27, 7.77)$ are in accord with this work.

$^{14}\text{O}^*(5.17)$ [$J^\pi = 1^-$], $\Gamma_\gamma/\Gamma = (7.2 \pm 3.5) \times 10^{-5}$; using $\Gamma_{\text{c.m.}}$ from Table 14.22, $\Gamma_\gamma = (2.7 \pm 1.3)$ eV (1989FE06). (1989AG1A; prelim.) report $\Gamma_\gamma = (7.6 \pm 3.8)$ eV.

$$4. \text{ (a) } ^{12}\text{C}(^{12}\text{C}, ^{10}\text{Be})^{14}\text{O} \quad Q_m = -20.6136$$

$$\text{ (b) } ^{12}\text{C}(^{14}\text{N}, ^{12}\text{B})^{14}\text{O} \quad Q_m = -18.513$$

At $E(^{12}\text{C}) = 480$ MeV (reaction (a)) forward-angle differential cross sections have been studied for $^{14}\text{O}^*(6.27, 9.9, 14.1, 15.7)$. $^{14}\text{O}^*(0, 6.59)$ are also populated. The forward spectra are dominated by $^{14}\text{O}^*(9.9)$ (1988KR11). For the earlier work on both reactions see (1976AJ04, 1981AJ01). See also (1988ME10).

$$5. ^{13}\text{C}(p, \pi^-)^{14}\text{O} \quad Q_m = -137.161$$

Differential cross sections have been measured at $E_p = 250$ MeV to $^{14}\text{O}^*(0, 5.17, 6.27 + 6.59, 9.92)$ and at $E_p = 354$ and 489 MeV to $^{14}\text{O}^*(0, 6.27 + 6.59)$ (1988HU04). At $E_p = 489$ MeV a broad structure near 23 MeV is also observed (1988HU06) but its origin is unknown (R.D. Bent

and G.M. Huber, private communication) [*Note*: a $T = 2$ state in ^{14}O , corresponding to $^{14}\text{C}^*(23.2)$ may be substantially broader and might be more difficult to detect].

At $E_{\bar{p}} = 200$ MeV angular distributions and A_y have been measured to $^{14}\text{O}^*(0, 5.17, 6.1[\text{u}], 6.6[\text{u}], 7.8, 9.7+9.9, 10.9, (12.0), 14.2, (14.6, 17.4))$. It is suggested that $^{14}\text{O}^*(14.15)$ has $J^\pi = 5^-$: see $^{13}\text{C}(p, \pi^+)^{14}\text{C}$ (reaction 15) (1987KO01, 1989KO21). For the earlier work see (1986AJ01). See also p. 104, (1986JA1H, 1987VI13) and (1986KU1J; theor.).

$$6. \ ^{13}\text{N}(p, \gamma)^{14}\text{O} \quad Q_m = 4.6280$$

This reaction is important in the hot-CNO cycle if its rate is dominated by $l = 0$ capture through $^{14}\text{O}^*(5.17)$. Calculations suggest Γ_γ for this state is 1.8 eV (1987FU02), ≥ 4.1 eV (1989DE28). See also (1986AJ01) and references below. For measurements see reactions 3 and 8 and, in particular, (1989FE06) [$\Gamma_\gamma = 7.6 \pm 3.8$ eV] for empirical S -factors as $f(E)$. See also (1990SMZZ) and (1982TR1A, 1983HA1B, 1985BA75, 1985CA41, 1986FI15, 1987BU12, 1988CA26, 1988JO1D, 1988RO04, 1988TR1C, 1989AG1A, 1989AR1G, 1989AR1H, 1989BA64).

$$7. \ ^{14}\text{C}(\pi^+, \pi^-)^{14}\text{O} \quad Q_m = -4.9866$$

Forward-angle cross sections have recently been measured for $E_{\pi^+} = 19$ to 79.5 MeV (1989LE11; 0°) and 300 to 500 MeV (1989WI02; 5°). For the earlier work see (1986AJ01). See also (1985AL15, 1986GI06, 1988SE1A, 1989LE1L) and (1987HA29, 1989CH1O, 1989ST1H, 1989YU1A, 1990CH14; theor.).

$$8. \ ^{14}\text{N}(p, n)^{14}\text{O} \quad Q_m = -5.9255$$

$$E_{\text{thresh.}} = 6353.04 \pm 0.08 \text{ keV (1981WH03).}$$

Angular distributions have been measured at $E_p = 35.2$ and 144 MeV [see (1986AJ01) and (1979MO16)] as well as at 35 MeV (1987OR01; to $^{14}\text{O}^*(5.17)$). A preliminary value for Γ_γ of $^{14}\text{O}^*(5.17)$ is ≈ 1 eV (1988WAZX) [see also the discussion in (1989FE06)]. See also (1984BA2E, 1990SMZZ) and (1988CA26, 1988LE08; astrophys.).

$$9. \ ^{14}\text{N}(^3\text{He}, t)^{14}\text{O} \quad Q_m = -5.1617$$

Triton groups have been observed at $E(^3\text{He}) = 44.6$ MeV to the first six states shown in Table 14.22 and to levels with $E_x = 6.79 \pm 0.03, 8.74 \pm 0.06, 9.74 \pm 0.03, 10.89 \pm 0.05, 11.24 \pm 0.05, 11.97$ (unresolved), $12.84 \pm 0.05, 13.01 \pm 0.05, 14.15 \pm 0.04, 14.64 \pm 0.06$ and 17.40 ± 0.06 MeV:

see (1981AJ01). [The states at 6.79 and 8.74 MeV reported in this reaction are relatively weakly excited and are not observed in reaction 3.] $\Gamma_{\text{c.m.}}$ of $^{14}\text{O}^*(5.17) = 38.1 \pm 1.8$ keV (1985CH06). See also (1987KO34, 1989DE1Q).

10. $^{16}\text{O}(p, t)^{14}\text{O}$ $Q_m = -20.4045$

Angular distributions of ground-state tritons have been studied to $E_p = 54.1$ MeV: see (1981AJ01). For comparison with the (p, ^3He) results see reaction 64 in ^{14}N .

Triton groups have been observed to states with $E_x = 5.21 \pm 0.04, 5.92 \pm 0.06, 6.28 \pm 0.05, 6.59, 7.77, 8.69 \pm 0.06$ [weak, not observed in reaction 3], and 9.65 ± 0.06 MeV. Angular distributions have been studied with polarized protons at $E_p = 43.8$ MeV to $^{14}\text{O}^*(0, 5.17, 6.27, 6.59, 7.77, 9.72)$: see (1976AJ04).

^{14}F
(Not illustrated)

^{14}F has not been observed: its atomic mass excess is predicted to be 32.98 MeV which would make it unstable with respect to decay into $^{13}\text{O} + p$ by 2.58 MeV: see (1981AJ01). See also (1986AN07; theor.).

$^{14}\text{Ne}, ^{14}\text{Na}, ^{14}\text{Mg}$
(Not illustrated)

$^{14}\text{Ne}, ^{14}\text{Na}$ and ^{14}Mg have not been observed. See (1986AN07; theor.).

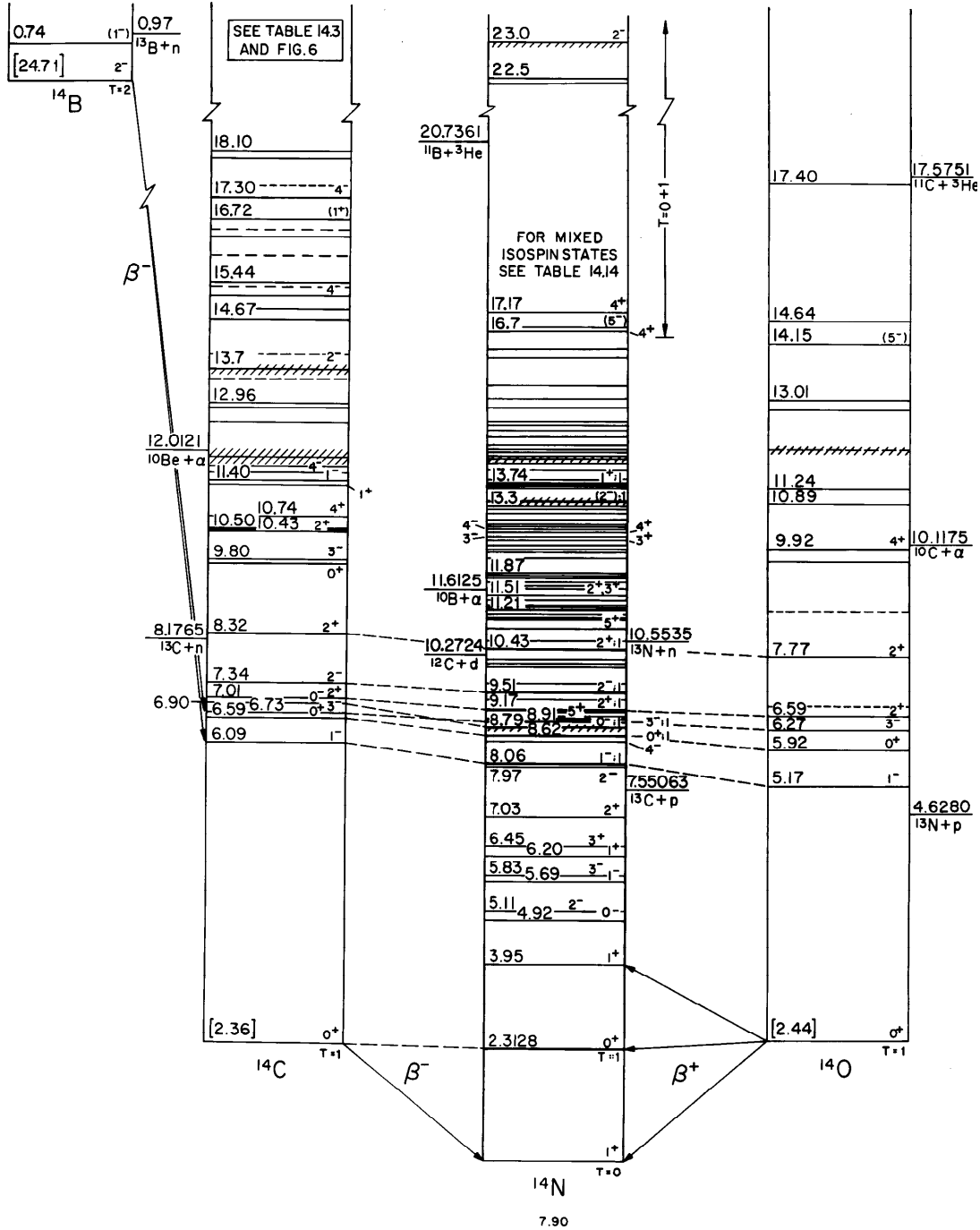

Figure 5: Isobar diagram, $A = 14$. The diagrams for individual isobars have been shifted vertically to eliminate the neutron-proton mass difference and the Coulomb energy, taken as $E_C = 0.60Z(Z - 1)/A^{1/3}$. Energies in square brackets represent the (approximate) nuclear energy, $E_N = M(Z, A) - ZM(H) - NM(n) - E_C$, minus the corresponding quantity for ^{14}C ; here M represents the atomic mass excess in MeV. Levels which are presumed to be isospin multiplets are connected by dashed lines.

References

(Closed 01 July 1990)

- 1959AJ76 F. Ajzenberg and T. Lauritsen, Nucl. Phys. 11 (1959) 1
- 1959GI47 J.H. Gibbons and R.L. Macklin, Phys. Rev. 114 (1959) 571
- 1961DA09 P. Dagley, W. Haeberli and J.X. Saladin, Nucl. Phys. 24 (1961) 353
- 1969BA06 G.C. Ball and J. Cerny, Phys. Rev. 177 (1969) 1466
- 1969SN04 J.L. Snelgrove and E. Kashy, Phys. Rev. 187 (1969) 1259
- 1970AJ04 F. Ajzenberg-Selove, Nucl. Phys. A152 (1970) 1
- 1971DU03 J.R. Duray and C.P. Browne, Phys. Rev. C3 (1971) 1867
- 1971GO40 N.B. Gove and M.J. Martin, Nucl. Data Tables A10 (1971) 205
- 1971RI15 H.T. Richards and H.V. Smith, Jr., Phys. Rev. Lett. 27 (1971) 1735
- 1972SM07 H.V. Smith, Jr., Phys. Rev. C6 (1972) 441
- 1973AJ01 F. Ajzenberg-Selove, H.G. Bingham and J.D. Garrett, Nucl. Phys. A202 (1973) 152
- 1973BA34 G.C. Ball, G.J. Costa, W.G. Davies, J.S. Forster, J.C. Hardy and A.B. McDonald, Phys. Rev. Lett. 31 (1973) 395
- 1973KL12 F.J. Kline, H. Crannell, J.T. O'Brien, J. McCarthy and R.R. Whitney, Nucl. Phys. A209 (1973) 381
- 1974AL11 D.E. Alburger and D.R. Goosman, Phys. Rev. C10 (1974) 912
- 1974JO01 P.L. Jolivette, Phys. Rev. C9 (1974) 16
- 1974NO01 J.W. Noe, D.P. Balamuth and R.W. Zurmuhle, Phys. Rev. C9 (1974) 132
- 1975WI04 S.J. Wilson, Phys. Rev. C11 (1975) 1071
- 1976AJ04 F. Ajzenberg-Selove, Nucl. Phys. A268 (1976) 1
- 1977CR02 H. Crannell, J.M. Finn, P. Hallowell, J.T. O'Brien, N. Ensslin, L.W. Fagg, E.C. Jones, Jr. and W.L. Bendel, Nucl. Phys. A278 (1977) 253
- 1978AJ02 F. Ajzenberg-Selove, E.R. Flynn and O. Hansen, Phys. Rev. C17 (1978) 1283
- 1978LEZA C.M. Lederer, V.S. Shirley, E. Browne, J.M. Dairiki, R.E. Doebler, A.A. Shihab-Eldin, L.J. Jardine, J.K. Tuli and A.B. Buyrn, Table of Isotopes 7th ed. (New York: John Wiley & Sons, 1978)
- 1978MO07 S. Mordechai, H.T. Fortune, G.E. Moore, M.E. Cobern, R.V. Kollarits and R. Middleton, J. Phys. G4 (1978) 407
- 1978MO08 S. Mordechai, H.T. Fortune, G.E. Moore, M.E. Cobern, R.V. Kollarits and R. Middleton, Nucl. Phys. A301 (1978) 463

- 1978WI04 D.H. Wilkinson, A. Gallmann and D.E. Alburger, Phys. Rev. C18 (1978) 401
- 1979EN01 N. Ensslin, L.W. Fagg, R.A. Lindgren, W.L. Bendel and E.C. Jones, Jr., Phys. Rev. C19 (1979) 569
- 1979KO26 L. Koester, K. Knopf and W. Waschkowski, Z. Phys. A292 (1979) 95
- 1979MO16 G.L. Moake, L.J. Gutay, R.P. Scharenberg, P.T. Debevec and P.A. Quin, Phys. Rev. Lett. 43 (1979) 910
- 1980HA30 M. Haji-Saeid, C. Glashausser, G. Igo, W. Cornelius, M. Gazzaly, F. Irom, J. McClelland, J.M. Moss, G. Pauletta, H.A. Thiessen et al., Phys. Rev. Lett. 45 (1980) 880
- 1980SC18 L.A. Schaller, L. Schellenberg, A. Ruetschi and H. Schneuwly, Nucl. Phys. A343 (1980) 333
- 1980WH03 W.R. Wharton, C.D. Goodman and D.C. Hensley, Phys. Rev. C22 (1980) 1138
- 1980WI13 H.S. Wilson, R.W. Kavanagh and F.M. Mann, Phys. Rev. C22 (1980) 1696
- 1980WI22 H. Winter and H.J. Andra, Phys. Rev. A21 (1980) 581
- 1981AJ01 F. Ajzenberg-Selove, Nucl. Phys. A360 (1981) 1
- 1981BI17 W. Biesiot and Ph.B. Smith, Phys. Rev. C24 (1981) 2443
- 1981JO02 P.L. Jolivette, Nucl. Phys. A370 (1981) 256
- 1981KO08 R.L. Kozub, J. Lin, J.F. Mateja, C.J. Lister, D.J. Millener and E.K. Warburton, Phys. Rev. C23 (1981) 1571
- 1981LA05 R.O. Lane, H.D. Knox, P. Hoffmann-Pinther, R.M. White and G.F. Auchampaugh, Phys. Rev. C23 (1981) 1883
- 1981WH03 R.E. White, H. Naylor, P.H. Barker, D.M.J. Lovelock and R.M. Smythe, Phys. Lett. B105 (1981) 116
- 1982AJ01 F. Ajzenberg-Selove, Nucl. Phys. A375 (1982) 1
- 1982BA1D Barnes, Essays in Nucl. Astrophys. (1982) 193
- 1982BH06 R.K. Bhalla and A.R. Poletti, Nucl. Phys. A390 (1982) 189
- 1982CA1A Cameron, Essays in Nucl. Astrophys. (1982) 23
- 1982FO01 H.T. Fortune and G.S. Stephans, Phys. Rev. C25 (1982) 1
- 1982MU14 S.F. Mughabghab, M.A. Lone and B.C. Robertson, Phys. Rev. C26 (1982) 2698
- 1982SC11 L.A. Schaller, L. Schellenberg, T.Q. Phan, G. Piller, A. Ruetschi and H. Schneuwly, Nucl. Phys. A379 (1982) 523
- 1982TR1A Truran, Essays in Nucl. Astrophys. (1982) 467
- 1982WA16 E.K. Warburton and D.E. Alburger, Nucl. Phys. A385 (1982) 189
- 1982WO1A Woosley and Weaver, Essays in Nucl. Astrophys. (1982) 377

- 1983AS01 D. Ashery, D.F. Geesaman, R.J. Holt, H.E. Jackson, J.R. Specht, K.E. Stephenson, R.E. Segel, P. Zupranski, H.W. Baer, J.D. Bowman et al., Phys. Rev. Lett. 50 (1983) 482
- 1983BA36 H.W. Baer, J.A. Bistirlich, K.M. Crowe, W. Dahme, C. Joseph, J.P. Perroud, M. Lebrun, C.J. Martoff, U. Straumann and P. Truol, Phys. Rev. C28 (1983) 761
- 1983BL11 M. Blecher, K. Gotow, R.L. Burman, M.V. Hynes, M.J. Leitch, N.S. Chant, L. Rees, P.G. Roos, F.E. Bertrand, E.E. Gross et al., Phys. Rev. C28 (1983) 2033
- 1983CS03 J. Cseh, A.Z. Kiss, E. Koltay, B. Nyako and E. Pintye, Nucl. Phys. A410 (1983) 147
- 1983GE03 D.F. Geesaman, D. Kurath, G.C. Morrison, C. Olmer, B. Zeidman, R.E. Anderson, R.L. Boudrie, H.A. Thiessen, G.S. Blanpied, G.R. Burleson et al., Phys. Rev. C27 (1983) 1134
- 1983HA1B M.J. Harris, W.A. Fowler, G.R. Caughlin and B.A. Zimmerman, Ann. Rev. Astron. Astrophys. 21 (1983) 165
- 1983IR04 F. Irom, J.R. Comfort, R. Jeppesen, J.J. Kraushaar, R.A. Ristinen, W. Tew, J.L. Ullmann, H.W. Baer, J.D. Bowman, M.D. Cooper et al., Phys. Rev. C28 (1983) 2565
- 1983VA28 O.I. Vasileva, V.M. Lebedev, A.V. Spassky, I.B. Teplov and L.N. Fateeva, Izv. Akad. Nauk SSSR, Ser. Fiz. 47 (1983) 2248
- 1984AD04 E.G. Adelberger, P. Hoodbhoy and B.A. Brown, Phys. Rev. C30 (1984) 456
- 1984AS05 D. Ashery, D.F. Geesaman, R.J. Holt, H.E. Jackson, J.R. Specht, K.E. Stephenson, R.E. Segel, P. Zupranski, H.W. Baer, J.D. Bowman et al., Phys. Rev. C30 (1984) 946
- 1984BA2E Barker et al., Proc. 2nd Int. Conf. (NBS-SP 617), Gaithersburg, MD 1981 (Washington, DC: NBS 1984) 345; Phys. Abs. 112083 (1985)
- 1984BE13 J.C. Bergstrom, R. Neuhausen and G. Lahm, Phys. Rev. C29 (1984) 1168
- 1984BO1H Bogdanova and Markushin, Sov. J. Part. Nucl. 15 (1984) 361
- 1984CL08 M.E. Clark and K.W. Kemper, Nucl. Phys. A425 (1984) 185
- 1984DE53 P. De Bievre, M. Gallet, N.E. Holden and I.L. Barnes, J. Phys. Chem. Ref. Data 13 (1984) 809
- 1984GI09 R. Gilman, H.T. Fortune, L.C. Bland, R.R. Kiziah, C.F. Moore, P.A. Seidl, C.L. Morris and W.B. Cottingham, Phys. Rev. C30 (1984) 958
- 1984KO42 V.P. Kondratev and L.V. Krasnov, Yad. Fiz. 40 (1984) 1371; Phys. At. Nucl. 40 (1984) 870
- 1984MA1P Marinov, Eshhar, Weil and Kolb, Phys. Rev. Lett. 52 (1984) 2209
- 1984NA1F Nakamura, Indian J. Phys. A58 (1984) 12
- 1984PE24 R.J. Peterson, H.C. Bhang, J.J. Hamill and T.G. Masterson, Nucl. Phys. A425 (1984) 469

- 1984PL02 M.A. Plum, R.A. Lindgren, J. Dubach, R.S. Hicks, R.L. Huffman, B. Parker, G.A. Peterson, J. Alster, J. Lichtenstadt, M.A. Moinester et al., Phys. Lett. B137 (1984) 15
- 1984TA07 T.N. Taddeucci, T.A. Carey, C. Gaarde, J. Larsen, C.D. Goodman, D.J. Horen, T. Masterson, J. Rapaport, T.P. Welch and E. Sugarbaker, Phys. Rev. Lett. 52 (1984) 1960
- 1984VA06 A.G.M. van Hees and P.W.M. Glaudemans, Z. Phys. A315 (1984) 223
- 1984XI1B Xie et al., Phys. Energ. Fortis Phys. Nucl. 8 (1984) 748; Phys. Abs. 53004 (1985)
- 1984ZH1B Zhuang Fei, Chen Hua-Zhong and Jin Xing-nan, Phys. Energ. Fortis Phys. Nucl. 8 (1984) 215
- 1985AB15 M.M. Abdel Hady, A.Z. Kiss, E. Koltay, B. Nyako and M. Hautala, Acta Phys. Acad. Sci. Hung. 58 (1985) 11
- 1985AD1A Adelberger and Haxton, Ann. Rev. Nucl. Part. Sci. 35 (1985) 501
- 1985AG1C Agalarov, Kerimov and Mourao, Moscow Univ. Phys. Bull. 40 (1985) 23; Phys. Abs. 5228 (1987)
- 1985AL15 A. Altman, R.R. Johnson, U. Wienands, N. Hessey, B.M. Barnett, B.M. Forster, N. Grion, D. Mills, F.M. Rozon, G.R. Smith et al., Phys. Rev. Lett. 55 (1985) 1273
- 1985AL16 G.D. Alkhazov, S.L. Belostotsky, A.A. Vorobyov, O.A. Domchenkov, Yu.V. Dot-senko, N.P. Kuropatkin and V.N. Nikulin, Yad. Fiz. 42 (1985) 8; Sov. J. Nucl. Phys. 42 (1985) 4
- 1985AL28 D.V. Aleksandrov, Yu.A. Glukhov, E.Yu. Nikolsky, B.G. Novatsky, A.A. Ogloblin and D.N. Stepanov, Izv. Akad. Nauk SSSR, Ser. Fiz. 49 (1985) 2111; Bull. Acad. Sci. USSR, Phys. Ser. 49 (1985) 26
- 1985AN28 M.S. Antony, J. Britz, J.B. Bueb and A. Pape, At. Data Nucl. Data Tables 33 (1985) 447
- 1985BA1A J.M. Bang, F.G. Gareev, W.T. Pinkston and J.S. Vaagen, Phys. Rep. 125 (1985) 253
- 1985BA1T Barnes, Lecture Notes in Phys. 219, Springer-Verlag (1985) 70
- 1985BA2G Barker, Jull and Donahue, Geophys. Res. Lett. 12 (1985) 737; Phys. Abs. 31271 (1986)
- 1985BA75 F.C. Barker, Aust. J. Phys. 38 (1985) 657
- 1985BE1A Beckerman, Phys. Rep. 129 (1985) 145
- 1985BE1C Berdnikov et al., in Leningrad (1985) 302
- 1985BE1K Bernstein, AIP Conf. Proc. 133 (1985) 271
- 1985BE40 C. Beck, F. Haas, R.M. Freeman, B. Heusch, J.P. Coffin, G. Guillaume, F. Rami and P. Wagner, Nucl. Phys. A442 (1985) 320

- 1985BE62 Ya.A. Berdnikov, V.I. Nikitchenko, V.I. Ostroumov, G.N. Smirnov, Yu.V. Trebukhovsky and A.P. Shishlo, *Yad. Fiz.* 42 (1985) 564; *Sov. J. Nucl. Phys.* 42 (1985) 357
- 1985BEZI R.V. Begzhanov, D.A. Gladyshev, O.Sh. Kobilov and G.A. Kulabdullaev, in *Leningrad (1985)* 49
- 1985BL17 M. Blann, *Phys. Rev. C* 32 (1985) 1231
- 1985BL22 G.S. Blanpied, B.G. Ritchie, M.L. Barlett, G.W. Hoffmann, J.A. McGill, M.A. Franey and M. Gazzaly, *Phys. Rev. C* 32 (1985) 2152
- 1985BR1E Brown, *Astrophys. J.* 297 (1985) 233
- 1985BR1F Broglia, Barranco and Gallardo, *Proc. Niels Bohr Cent. Conf., Copenhagen 1985 (Amsterdam, Netherlands: North-Holland 1985)* 193; *Phys. Abs.* 37229 (1986)
- 1985CA41 G.R. Caughlan, W. A. Fowler, M.J. Harris and B.A. Zimmerman, *At. Data Nucl. Data Tables* 32 (1985) 197
- 1985CE11 C. Cerruti, D. Guinet and A. Demeyer, *Z. Phys.* A321 (1985) 633
- 1985CH06 T.E. Chupp, R.T. Kouzes, A.B. McDonald, P.D. Parker, T.F. Wang and A. Howard, *Phys. Rev. C* 31 (1985) 1023
- 1985CH1F Cheon, *New Phys.* 25 (1985) 98; *Phys. Abs.* 123501 (1985)
- 1985CH1G Cheon, *J. Korean Phys. Soc.* 18 (1985) 95; *Phys. Abs.* 67807 (1987)
- 1985CO15 B.H. Cottman, K. Min, P. Stoler, P.K. Teng, E.J. Winhold, M. Yamazaki, P.F. Yergin, A.M. Bernstein, K.I. Blomqvist, J.H.J. Distelbrink et al., *Phys. Rev. Lett.* 55 (1985) 684
- 1985CU1A B. Cujec, *Lecture Notes in Phys.* 219 (1985)108
- 1985DE17 E. Descroix, M. Bedjidian, J.Y. Grossiord, A. Guichard, M. Gusakow, M. Jacquin, J.R. Pizzi and G. Bagieu, *Nucl. Phys.* A438 (1985) 112
- 1985DW1A Dwyer and Meyer, *Astrophys. J.* 294 (1985) 441
- 1985FU1C Fuller, *Phys. Rep.* 127 (1985) 185
- 1985GO1A Goncharova, Kissener and Eramzhyan, *Sov. J. Part. Nucl.* 16 (1985) 337
- 1985GO1B N.G. Goncharova, Kh.R. Kissener and R.A. Eramzhyan, *Izv. Akad. Nauk. SSSR Ser. Fiz.* 49 (1985) 1032; *Bull. Acad. Sci. USSR Phys. Ser.* 49 (1985) 184
- 1985GO1R Gove et al., *Bull. Amer. Phys. Soc.* 30 (1985) 1249
- 1985GO27 C.R. Gossett, *Nucl. Instr. Meth. Phys. Res.* B10-11 (1985) 722
- 1985GOZP A.N. Goltsov and N.G. Goncharova, in *Leningrad (1985)* 182
- 1985HA38 E.L. Haase and I. Khubeis, *Nucl. Instrum. Meth. Phys. Res.* B10-11 (1985) 727

- 1985HO07 D.B. Holtkamp, S.J. Seestrom-Morris, D. Dehnhard, H.W. Baer, C.L. Morris, S.J. Greene, C.J. Harvey, D. Kurath and J.A. Carr, *Phys. Rev. C* 31 (1985) 957; Erratum *Phys. Rev. C* 41 (1990) 1319
- 1985HO21 E. Hourani, M. Hussonnois, L. Stab, L. Brillard, S. Gales and J.P. Schapira, *Phys. Lett. B* 160 (1985) 375
- 1985HU04 M.S. Hussein, B.V. Carlson, O. Civitarese and A. Szanto De Toledo, *Phys. Rev. Lett.* 54 (1985) 2659
- 1985IR02 F. Irom, M.J. Leitch, H.W. Baer, J.D. Bowman, M.D. Cooper, B.J. Dropesky, E. Piasetzky and J.N. Knudson, *Phys. Rev. Lett.* 55 (1985) 1862
- 1985KA1A S. Kato, N. Matsuoka, T. Noro, T. Saito, H. Sakai, M. Nakamura, M. Yosoi, T. Ichihara, K. Hatanaka and H. Ogawa, *Nucl. Instrum. Meth. Phys. Res. A* 238 (1985) 453
- 1985KA1E Kadenskii and Chuvilskii, in *Leningrad* (1985) 437, 440
- 1985KA1G Kadenskii, Furman and Chuvilskii, in *Leningrad* (1985) 439
- 1985KAZQ S.G. Kadenskii, S.D. Kurgalin and Yu.M. Chuvilskii, in *Leningrad* (1985) 438
- 1985KO04 D. Konnerth, W. Trombik, K.G. Bernhardt, K.A. Eberhard, R. Singh, A. Strzalkowski and W. Trautmann, *Nucl. Phys. A* 436 (1985) 538
- 1985KO1J Koonin, *Lecture Notes in Physics* 219, Springer-Verlag (1985) 129
- 1985KO1V Kozeratskaya, Stapanenko, Nemets and Shvedov, in *Leningrad* (1985) 377
- 1985KO1Y J.H. Koch, *Nucl. Phys. A* 446 (1985) 331
- 1985KO39 K. Koshigiri, Y. Kakudo, H. Ohtsubo and M. Morita, *Prog. Theor. Phys.* 74 (1985) 736
- 1985KU01 P.C-K. Kuo, K.G. McNeill, N.K. Sherman, S. Landsberger, W.F. Davidson, J.W. Jury and J.R.C. Lafontaine, *Phys. Rev. C* 31 (1985) 318
- 1985KU24 W. Kutschera, I. Ahmad, S.G. Armato III, A.M. Friedman, J.E. Gindler, W. Henning, T. Ishii, M. Paul and K.E. Rehm, *Phys. Rev. C* 32 (1985) 2036
- 1985KW02 E. Kwasniewicz and L. Jarczyk, *Nucl. Phys. A* 441 (1985) 77
- 1985KW03 E. Kwasniewicz, J. Kisiel and L. Jarczyk, *Acta Phys. Pol.* B16 (1985) 947
- 1985LA20 I.A. Lantsev, V.I. Ostroumov, Yu.R. Gismatulin, V.N. Zbarag and A.A. Melentev, *Izv. Akad. Nauk SSSR, Ser. Fiz.* 49 (1985) 143; *Bull. Acad. Sci. USSR, Phys. Ser.* 49 (1985) 149
- 1985MA56 E. Maglione, G. Pollarolo, A. Vitturi, R.A. Broglia and A. Winther, *Phys. Lett. B* 162 (1985) 59
- 1985ME1E Melenevskii, Muzika, Romanova and Tikhii, in *Leningrad* (1985) 499
- 1985MI16 C.S. Mishra, B.M. Preedom, B.G. Ritchie, R.S. Moore, M. Blecher, K. Gotow, R.L. Burman, M.V. Hynes, E. Piasetzky, N.S. Chant et al., *Phys. Rev. C* 32 (1985) 995
- 1985MI23 T.A. Minelli, A. Pascolini and C. Villi, *Nuovo Cim.* A90 (1985) 185

- 1985PE10 J.S. Petler, M.S. Islam, R.W. Finlay and F.S. Dietrich, Phys. Rev. C32 (1985) 673
- 1985PO10 N.A.F.M. Poppelier, L.D. Wood and P.W.M. Glaudemans, Phys. Lett. B157 (1985) 120
- 1985PO11 D.N. Poenaru, M. Ivascu, A. Sandulescu and W. Greiner, Phys. Rev. C32 (1985) 572
- 1985PO12 D.N. Poenaru, M. Ivascu, A. Sandulescu and W. Greiner, Rev. Roum. Phys. 30 (1985) 173
- 1985PO14 D.N. Poenaru and M. Ivascu, J. Phys. Lett. 46 (1985) L591
- 1985PR03 C. Pruneau, M.B. Chatterjee, C. Rangacharyulu and C. St-Pierre, Can. J. Phys. 63 (1985) 1141
- 1985PR1D Prombo and Clayton, Science 230 (1985) 935
- 1985PY01 R.E. Pywell, B.L. Berman, J.G. Woodworth, J.W. Jury, K.G. McNeill and M.N. Thompson, Phys. Rev. C32 (1985) 384
- 1985RO05 K. Rohrich, L. Tiator, G. Kobschall, Ch. Reifferscheid, Ch. Schmitt, V.H. Walther, K. Weinand and L.E. Wright, Phys. Lett. B153 (1985) 203
- 1985RO10 G. Roepke, H. Schulz, L.N. Andronenko, A.A. Kotov, W. Neubert and E.N. Volnin, Phys. Rev. C31 (1985) 1556
- 1985RO17 F. Roig and J. Navarro, Nucl. Phys. A440 (1985) 659
- 1985SH1D Shvedov and Nemets, in Leningrad (1985) 317
- 1985SH1G Shen, Qiao, Zhu and Zhan, Chin. Phys. 5 (1985) 657
- 1985SI19 K. Siwek-Wilczynska, R.A. Blue, L.H. Harwood, R.M. Ronningen, H. Utsunomiya, J. Wilczynski and D.J. Morrissey, Phys. Rev. C32 (1985) 1450
- 1985ST1B R.G. Stokstad, Treatise on Heavy-Ion Sci. 3 (1985) 83
- 1985ST20 G.S.F. Stephans, D.G. Kovar, R.V.F. Janssens, G. Rosner, H. Ikezoe, B. Wilkins, D. Henderson, K.T. Lesko, J.J. Kolata, C.K. Gelbke et al., Phys. Lett. B161 (1985) 60
- 1985TA1A Taam, Ann. Rev. Nucl. Part. Sci. 35 (1985) 1
- 1985TA23 T.N. Taddeucci, C.D. Goodman, R.C. Byrd, T.A. Carey, D.J. Horen, J. Rapaport and E. Sugarbaker, Nucl. Instrum. Meth. A241 (1985) 448
- 1985TE01 J.A. Templon, J.H. Dave, C.R. Gould and S. Singkarat, Nucl. Sci. Eng. 91 (1985) 451
- 1985TU1B W. Turchinets, Nucl. Phys. A446 (1985) 23
- 1985UM01 A.S. Umar, M.R. Strayer, R.Y. Cusson, P.-G. Reinhard and D.A. Bromley, Phys. Rev. C32 (1985) 172
- 1985VI01 F. Videbaek, O. Hansen, B.S. Nilsson, E.R. Flynn and J.C. Peng, Nucl. Phys. A433 (1985) 441
- 1985VI09 A.C.C. Villari, F.I.A. Almeida and A. Lepine-Szily, Phys. Lett. B165 (1985) 247

- 1985WA22 S. Wald, S.B. Gazes, C.R. Albiston, Y. Chan, B.G. Harvey, M.J. Murphy, I. Tserruya, R.G. Stokstad, P.J. Countryman, K. Van Bibber et al., Phys. Rev. C32 (1985) 894
- 1985WA24 J.W. Watson, W. Pairsuwan, B.D. Anderson, A.R. Baldwin, B.S. Flanders, R. Madey, R.J. McCarthy, B.A. Brown, B.H. Wildenthal and C.C. Foster, Phys. Rev. Lett. 55 (1985) 1369
- 1985WE06 W.-M. Wandler and M. Micklinghoff, Nucl. Phys. A439 (1985) 13
- 1985WR01 M.C. Wright, H. Kitazawa, N.R. Roberson, H.R. Weller, M. Jensen and D.R. Tilley, Phys. Rev. C31 (1985) 1125
- 1985ZI05 W. Zickendraht, Ann. Phys. 42 (1985) 113
- 1986AD01 E.G. Adelberger, P. Hoodbhoy and B.A. Brown, Phys. Rev. C33 (1986) 1840
- 1986ADZT E.G. Adelberger, in AIP Conf. Proc. 150 (1986) 1177
- 1986AI04 A. Ait Haddou, M. Berrada and G. Paic, J. Radioanal. Nucl. Chem. 102 (1986) 159
- 1986AI1A Aichelin and Stocker, Phys. Lett. B176 (1986) 14
- 1986AJ01 F. Ajzenberg-Selove, Nucl. Phys. A449 (1986) 1
- 1986AJ04 F. Ajzenberg-Selove, Nucl. Phys. A460 (1986) 1
- 1986AL09 N. Alamanos, P. Braun-Munzinger, R.F. Freifelder, P. Paul, J. Stachel, T.C. Awes, R.L. Ferguson, F.E. Obenshain, F. Plasil and G.R. Young, Phys. Lett. B173 (1986) 392
- 1986AL18 W.P. Alford, R.L. Helmer, R. Abegg, A. Celler, O. Hausser, K. Hicks, K.P. Jackson, C.A. Miller, S. Yen, R.E. Azuma et al., Phys. Lett. B179 (1986) 20
- 1986AN07 M.S. Antony, J. Britz and A. Pape, At. Data Nucl. Data Tables 34 (1986) 279
- 1986AN1R Ansari, Shoeb and Rahman Khan, J. Phys. G12 (1986) 1369
- 1986AN29 N. Anantaraman, J.S. Winfield, S.M. Austin, A. Galonsky, J. van der Plicht, C.C. Chang, G. Ciangaru and S. Gales, Phys. Rev. Lett. 57 (1986) 2375
- 1986AO1A Aoki, J. Phys. Soc. Jpn. Suppl. 55 (1986) 123
- 1986AR1F Artikov et al., Sov. J. Nucl. Phys. 44 (1986) 255
- 1986BA16 D. Bachelier, J.L. Boyard, T. Hennino, J.C. Jourdain, M. Roy-Stephan, D. Contardo, J.Y. Grossiord, A. Guichard, J.R. Pizzi, P. Radvanyi et al., Phys. Lett. B172 (1986) 23
- 1986BA1C Baer and Miller, Comments Nucl. and Part. Phys. 15 (1986) 269
- 1986BA26 S.W. Barwick, P.B. Price, H.L. Ravn, E. Hourani and M. Hussonnois, Phys. Rev. C34 (1986) 362
- 1986BA2W Balestra et al., AIP Conf. Proc. 150 (1986) 526
- 1986BA62 W. Bauer, G.F. Bertsch, W. Cassing and U. Mosel, Phys. Rev. C34 (1986) 2127
- 1986BA69 D. Baye, Nucl. Phys. A460 (1986) 581

- 1986BE1P Bernstein, Private Communication (1986)
- 1986BE35 A.V. Belozyorov, C. Borcea, Z. Dlouhy, A.M. Kalinin, R. Kalpakchieva, Nguyen Hoai Chau, Yu.Ts. Oganessian and Yu.E. Penionzhkevich, Nucl. Phys. A460 (1986) 352
- 1986BE42 Ya.A. Berdnikov, B.A. Likhachev, V.I. Ostroumov, G.N. Smirnov and Yu.V. Trebukhovskiy, Yad. Fiz. 44 (1986) 872; Sov. J. Nucl. Phys. 44 (1986) 562
- 1986BE54 A.V. Belozorov, K. Borchia, Z. Dlouhy, A.M. Kalinin, Nguyen Hoai Tyau and Yu.E. Penionzhkevich, Pisma Zh. Eksp. Teor. Fiz. 44 (1986) 498; JETP Lett. (USSR) 44 (1986) 641
- 1986BI1A Bimbot et al., J. Phys. (France) 47 (1986) C4-241
- 1986BO1B Bogdanov et al., JETP Lett. 44 (1986) 391
- 1986BO1K Borisov, Komkov and Leonov, in Kharkov (1986) 560
- 1986BO1L Borzonov et al., in P7-86-322, Dubna (1986) 66
- 1986BO1N Bowman, Proc. Int. Nucl. Phys. Conf., Harrogate, U.K., Vol. 2, No. 68 (1986) 83; Publ. by Institute of Phys., Bristol, U.K.
- 1986BR33 V.N. Bragin, F.A. Gareev, S.A. Goncharov, A.S. Demyanova, S.N. Ershov, P.P. Korovin, A.L. Lebedev and A.A. Ogloblin, Pisma Zh. Eksp. Teor. Fiz. 43 (1986) 504; JETP Lett. 43 (1986) 652
- 1986CA1N Carey, J. Phys. Soc. Jpn. Suppl. 55 (1986) 172
- 1986CE04 C. Cernigoi, N. Grion, G. Pauli, R. Rui and R. Cherubini, Nucl. Phys. A456 (1986) 599
- 1986CH1H Chugai, Sov. Astron. Lett. 12 (1986) 120
- 1986CH2F Chardine, Haouat, Seguin and Humeau, CEA-N-2506 (1986)
- 1986CI1B Cimbak et al., Nucl. Instr. Meth. Phys. Res. B17 (1986) 560
- 1986CL1C Clegg, J. Phys. Soc. Jpn. Suppl. 55 (1986) 535
- 1986CO1Q Court and Heyes, Nucl. Instr. Meth. Phys. Res. A243 (1986) 37
- 1986CO1R Cottrell and Sneden, Astron. Astrophys. 161 (1986) 314
- 1986COZO M.D. Cohler, D.L. Watson, R. Wadsworth, M.J. Smithson, J.M. O'Donnell, J.B.A. England, L. Zybert, R. Zybert, N. Clarke and K. Pearce, Proc. Int. Nucl. Phys. Conf., Harrogate, U.K., (1986) 411
- 1986CS1A Csernai and Kapusta, Phys. Rep. 131 (1986) 223
- 1986CS1B Csongor and Hertelendi, Nucl. Instr. Meth. Phys. Res. B17 (1986) 493
- 1986CU01 M.S. Curtin, L.H. Harwood, J.A. Nolen, B. Sherrill, Z.Q. Xie and B.A. Brown, Phys. Rev. Lett. 56 (1986) 34
- 1986CU02 B. Cujec, B. Dasmahapatra, Q. Haider, F. Lahlou and R.A. Dayras, Nucl. Phys. A453 (1986) 505

- 1986DA1B Davis and Pniewski, *Contemp. Phys.* 27 (1986) 91
- 1986DA1G Dalitz, Davis and Tovee, *Nucl. Phys.* A450 (1986) 311c
- 1986DE32 H.G. de Carvalho, J.B. Martins and O.A.P. Tavares, *Phys. Rev.* C34 (1986) 2261
- 1986DO11 T.W. Donnelly and A.S. Raskin, *Ann. Phys.* 169 (1986) 247
- 1986DO1L Dominy, Wallerstein and Suntzeff, *Astrophys. J.* 300 (1986) 325
- 1986DO1M Donahue, *Bull. Amer. Phys. Soc.* 31 (1986) 1266
- 1986DR03 P.V. Drumm, O. Karban, A.K. Basak, P.M. Lewis, S. Roman and G.C. Morrison, *Nucl. Phys.* A448 (1986) 93
- 1986DR1F Drummond et al., *Bull. Amer. Phys. Soc.* 31 (1986) 1215
- 1986DU03 DubovoI and Chitanava, *Sov. J. Nucl. Phys.* 43 (1986) 373
- 1986DU1K Dubus, Margail and Martin, *Nucl. Instr. Meth. Phys. Res.* B15 (1986) 559
- 1986DY02 S.A. Dytman and F. Tabakin, *Phys. Rev.* C33 (1986) 1699
- 1986EF1A Efremov et al., N P7-86-322, Dubna (1986) 73
- 1986EL1C C. Ellegaard, *AIP Conf. Proc.* 142 (1986) 391
- 1986ER1A Eramzhyan, Ishkhanov, Kapitonov and Neudatchin, *Phys. Rep.* 136 (1986) 229
- 1986FE1A Fetisov et al., *Czech. J. Phys.* 36 (1986) 451
- 1986FI15 Filippone, *Ann. Rev. Nucl. Part. Sci.* 36 (1986) 717
- 1986FO06 H.T. Fortune and R. Gilman, *Phys. Rev.* C33 (1986) 2171
- 1986GA18 M. Garcon, B. Bonin, G. Bruge, J.C. Duchazeaubeneix, M. Rouger, J. Saudinos, B.H. Silverman, D.M. Sheppard, J. Arvieux, G. Gaillard et al., *Nucl. Phys.* A458 (1986) 287
- 1986GA1H Gal, *AIP Conf. Proc.* 150 (1986) 127
- 1986GE06 W.J. Gerace, W.J. Leonard and D.A. Sparrow, *Phys. Rev.* C34 (1986) 353
- 1986GEZX M.K. Georgieva, D.V. Elenkov, G.Kh. Tumbev, in Kharkov (1986) 52
- 1986GI06 R. Gilman, H.T. Fortune, J.D. Zumbro, P.A. Seidl, C.F. Moore, C.L. Morris, J.A. Faucett, G.R. Burleson, S. Mordechai and K.S. Dhuga, *Phys. Rev.* C33 (1986) 1082
- 1986GL1A Glaudemans, *AIP Conf. Proc.* 142 (1986) 316
- 1986GO1B Gorionov et al., in Kharkov (1986) 373
- 1986GO1H Gorionov et al., in Kharkov 86 (1986) 374
- 1986GO28 N.F. Golovanova and V.V. Kurovsky, *Izv. Akad. Nauk SSSR Ser. Fiz.* 50 (1986) 963; *Bull. Acad. Sci. USSR Phys. Ser.* 50 (1986) 131
- 1986GO29 A.N. Goltsov and N.G. Goncharova, *Izv. Akad. Nauk SSSR, Ser. Fiz.* 50 (1986) 996; *Bull. Acad. Sci. USSR, Phys. Ser.* 50, No.5 (1986) 164

- 1986GR1A Gregoire and Tamain, *Ann. Physique* 11 (1986) 323
- 1986GR1B Grashin et al., *Izv. Akad. Nauk SSSR Ser. Fiz.* 50 (1986) 944
- 1986GU1F Gupta and Malik, in *Harrogate* (1986) C23
- 1986HA13 Q. Haider and F.B. Malik, *J. Phys.* G12 (1986) 537
- 1986HA1B Harvey, *J. Phys.* 47 (1986) C4-29
- 1986HA1E Harney, Richter and Weidenmuller, *Rev. Mod. Phys.* 58 (1986) 607
- 1986HA2D Hashimoto et al., *Astrophys. J.* 307 (1986) 687
- 1986HA2E Harvey et al., *Phys. Rev.* C33 (1986) 1454
- 1986HA49 T.-K. Ha, *Z. Naturforsch.* 41A (1986) 163
- 1986HE1F Heaton et al., *Nature* 322 (1986) 822
- 1986HE26 E.F. Hefter and I.A. Mitropolsky, *Nuovo Cim.* A95 (1986) 63
- 1986HI06 R.S. Hicks, R.A. Lindgren, M.A. Plum, G.A. Peterson, H. Crannell, D.I. Sober, H.A. Thiessen and D.J. Millener, *Phys. Rev.* C34 (1986) 1161
- 1986HO1L Horvatincic et al., *Nucl. Instr. Meth. Phys. Res.* B17 (1986) 550
- 1986HO1N Ho, *Chin. Phys. Lett.* 3 (1986) 369; *Phys. Abs.* 5236 (1987)
- 1986HO26 B. Hoheisel, D. Kamke and M. Schluckebier, *Z. Phys.* A325 (1986) 317
- 1986IR01 M. Iriondo, D. Jerrestam and R.J. Liotta, *Nucl. Phys.* A454 (1986) 252
- 1986IS02 K. Ishida, J.H. Brewer, T. Matsuzaki, Y. Kuno, J. Imazato and K. Nagamine, *Phys. Lett.* B167B (1986) 31
- 1986IS07 V.I. Isakov and M.I. Strikman, *Phys. Lett.* B181 (1986) 195
- 1986JA07 W.Jaus and G. Rasche, *Aust. J. Phys.* 39 (1986) 1
- 1986JA1H Jacobs, *AIP Conf. Proc.* 142 (1986) 181
- 1986JE1B Jeong and Cheon, *J. Korean Phys. Soc.* 19 (1986) 157; *Phys. Abs.* 89541 (1987)
- 1986KA1Z Kato et al., *J. Phys. Soc. Jpn. Suppl.* 55 (1986) 1110
- 1986KI12 N.S.P. King, P.W. Lisowski, G.L. Morgan, P.N. Craig, R.G. Jeppesen, D.A. Lind, J.R. Shepard, J.L. Ullmann, C.D. Zafiratos, C.D. Goodman et al., *Phys. Lett.* B175 (1986) 279
- 1986KI1J Kieser et al., *Nucl. Instr. Meth. Phys. Res.* B15 (1986) 718
- 1986KO08 P. Kozma and P. Bem, *Czech. J. Phys.* B36 (1986) 462
- 1986KO1A Kolesnikov et al., in *Kharkov* (1986) 225
- 1986KO1E H. Koch, *AIP Conf. Proc.* 150 (1986) 490
- 1986KO1G Korkmaz et al., *J. Phys. Soc. Jpn. Suppl.* 55 (1986) 918
- 1986KO1K Korber, Beckmann, Holm and Lindner, *J. Phys. Soc. Jpn. Suppl.* 55 (1986) 632

- 1986KO2A Kostadinov and Yanev, Nucl. Instr. Meth. Phys. Res. B17 (1986) 511
- 1986KU1J Kume, J. Phys. Soc. Jpn. Suppl. 55 (1986) 920
- 1986LA1C Lambert et al., Astrophys. J. Suppl. 62 (1986) 373
- 1986LAZL Lantsev et al., in Kharkov (1986) 314
- 1986LI1C Lindgren et al., AIP Conf. Proc. 142 (1986) 133
- 1986LI1M Li et al., J. Phys. Soc. Jpn. Suppl. 55 (1986) 564
- 1986MA13 J.F. Mateja, A.D. Frawley, R.A. Parker and K. Sartor, Phys. Rev. C33 (1986) 1307
- 1986MA19 J.F. Mateja, A.D. Frawley, L.C. Dennis and K. Sartor, Phys. Rev. C33 (1986) 1649
- 1986MA1C Majling et al., Nucl. Phys. A450 (1986) 189c
- 1986MA1E Matteucci, Astrophys. J. 305 (1986) L81
- 1986MA32 N. Matsuoka, H. Sakai, T. Saito, K. Hosono, M. Kondo, H. Ito, K. Hatanaka, T. Ichihara, A. Okihana, K. Imai et al., Nucl. Phys. A455 (1986) 413
- 1986ME06 M.C. Mermaz, T. Suomijarvi, R. Lucas, B. Berthier, J. Matuszek, J.P. Coffin, G. Guillaume, B. Heusch, F. Jundt and F. Rami, Nucl. Phys. A456 (1986) 186
- 1986ME1F D.F. Measday, Czech. J. Phys. 36 (1986) 395
- 1986MO13 D.J. Morrissey, C. Bloch, W. Benenson, E. Kashy, R.A. Blue, R.M. Ronningen and R. Aryaeinejad, Phys. Rev. C34 (1986) 761
- 1986MO27 T. Motobayashi, H. Sakai, N. Matsuoka, T. Saito, K. Hosono, A. Okihana, M. Ishihara, S. Shimoura and A. Sakaguchi, Phys. Rev. C34 (1986) 2365
- 1986NO1C Nojiri et al., J. Phys. Soc. Jpn. Suppl. 55 (1986) 391
- 1986OH03 H. Ohnuma, B.A. Brown, D. Dehnhard, K. Furukawa, T. Hasegawa, S. Hayakawa, N. Hoshino, K. Ieki, M. Kabasawa, K. Maeda et al., Nucl. Phys. A456 (1986) 61
- 1986OS05 A. Osman and S.S. Abdel-Aziz Indian, J. Pure Appl. Phys. 24 (1986) 65; Phys. Abs. 84172 (1986)
- 1986PA1N Pan, Yuan and Yang, Chin. Phys. Lett. 3 (1986) 145
- 1986PA23 A. Passoja, Phys. Scr. 34 (1986) 634
- 1986PE05 J.P. Perroud, A. Perrenoud, J.C. Alder, B. Gabioud, C. Joseph, J.F. Loude, N. Morel, M.T. Tran, E. Winkelmann, H. Von Fellenberg et al., Nucl. Phys. A453 (1986) 542
- 1986PE1E Prtrovich, Carr and McManus, Ann. Rev. Nucl. Part. Sci. 36 (1986) 29
- 1986PH1A Pham Ngoc Chiong, Ter-Akopyan and Ivanov, IN P7-86-322, Dubna (1986) 81
- 1986PI11 G.A. Pik-Pichak, Yad. Fiz. 44 (1986) 1421; Sov. J. Nucl. Phys. 44 (1986) 923
- 1986PL02 R. Planeta, P. Belery, J. Brzywczyk, P. Cohilis, Y. El Masri, Gh. Gregoire, K. Gro-towski, Z. Majka, S. Micek, M. Szczodrak et al., Phys. Rev. C34 (1986) 512

- 1986PO06 D.N. Poenaru, W. Greiner, K. Depta, M. Ivascu, D. Mazilu and A. Sandulescu, *At. Data Nucl. Data Tables* 34 (1986) 423
- 1986PO15 D.N. Poenaru, W. Greiner, M. Ivascu, D. Mazilu and I.H. Plonski, *Z. Phys.* A325 (1986) 435
- 1986POZW L. Potvin, *Bull. Amer. Phys. Soc.* 31 (1986) 1216
- 1986PR01 M. Prakash, P. Braun-Munzinger and J. Stachel, *Phys. Rev.* C33 (1986) 937
- 1986PR1B Price, in *Dubna* (1986) 51
- 1986RA05 L. Ray, G.W. Hoffmann, M.L. Barlett, J.J. Jarmer, B.C. Clark, R.E. Kozack, R.L. Mercer, G.R. Burleson and S. Hama, *Phys. Rev. Lett.* 56 (1986) 2465
- 1986RA1J G.M. Radetskii, *Izv. Vyssh. Uch. Zav. Fiz. SSSR* 29 (1986) 45; *Sov. Phys. J. (USA)* 29 (1986) 903
- 1986RE14 B.A. Remington, M. Blann and G.F. Bertsch, *Phys. Rev. Lett.* 57 (1986) 2909
- 1986RO03 R. Rockmore and B. Saghai, *Phys. Rev.* C33 (1986) 576
- 1986RO12 G. Royer, *J. Phys.* G12 (1986) 623
- 1986RO18 C. Rolfs and R.W. Kavanagh, *Nucl. Instr. Meth. Phys. Res.* A247 (1986) 507
- 1986RO1Q Roy-Stephan et al., *Nucl. Phys.* A447 (1986) 635c
- 1986RO23 D. Rohmann, H. Barth, A.D. Hancock, H. Koch, Th. Kohler, A. Kreissl, H. Poth, U. Raich, A. Wolf, L. Tauscher et al., *Z. Phys.* A325 (1986) 261
- 1986SA06 S. Sakaguchi, K. Nagatani, M. Torikoshi, S.I. Hayakawa, T. Motobayashi, O. Satoh, T. Yamaya, M. Fujiwara, N. Matsuoka and H. Sakai, *Phys. Rev. Lett.* 56 (1986) 1112
- 1986SA2E Savage, McKeown, Fillippone and Mitchell, *Phys. Rev. Lett.* 57 (1986) 178
- 1986SA2G Sakamoto et al., *J. Phys. Soc. Jpn. Suppl.* 55 (1986) 662
- 1986SA30 H. Sato and Y. Okuhara, *Phys. Rev.* C34 (1986) 2171
- 1986SC35 R.L. Schulte, J.M. Papazian and P.N. Adler, *Nucl. Instrum. Meth. Phys. Res.* B15 (1986) 550
- 1986SH1F Shen et al., *Chin. Phys.* 6 (1986) 80
- 1986SH25 B. Shivakumar, D. Shapira, P.H. Stelson, M. Beckerman, B.A. Harmon, K. Teh and D.A. Bromley, *Phys. Rev. Lett.* 57 (1986) 1211
- 1986SH2B Shibata and Fujita, *Phys. Lett.* B172 (1986) 283
- 1986SI11 E.R. Siciliano, M.D. Cooper, M.B. Johnson and M.J. Leitch, *Phys. Rev.* C34 (1986) 267
- 1986SI1D Simpson and Earwaker, *Nucl. Instrum. Meth. Phys. Res.* B15 (1986) 502
- 1986SI1H A. Sirlin and R. Zucchini, *Phys. Rev. Lett.* 57 (1986) 1994
- 1986SM1A Smith and Lambert, *Astrophys. J.* 311 (1986) 843

- 1986SO10 L.G. Sobotka, D.G. Sarantites, H. Puchta, F.A. Dilmanian, M. Jaaskelainen, M.L. Halbert, J.H. Barker, J.R. Beene, R.L. Ferguson, D.C. Hensley et al., Phys. Rev. C34 (1986) 917
- 1986SP01 D.A. Sparrow, Phys. Rev. C33 (1986) 287
- 1986SR1B Srdoc, Nucl. Instrum. Meth. Phys. Res. B17 (1986) 545
- 1986ST03 J. Stachel, P. Braun-Munzinger, R.H. Freifelder, P. Paul, S. Sen, P. DeYoung, P.H. Zhang, T.C. Awes, F.E. Obenshain, F. Plasil et al., Phys. Rev. C33 (1986) 1420
- 1986ST07 J. Stevenson, K.B. Beard, W. Benenson, J. Clayton, E. Kashy, A. Lampis, D.J. Morrissey, M. Samuel, R.J. Smith, C.L. Tam et al., Phys. Rev. Lett. 57 (1986) 555
- 1986ST1A Steadman and Rhoades-Brown, Ann. Rev. Nucl. Part. Sci. 36 (1986) 649
- 1986ST1J Stock, Phy. Rep. 135 (1986) 259
- 1986ST1K Stevenson, Espe, Reiter and Lovett, Nature 323 (1986) 522
- 1986STZY S.M. Sterbenz, M. Gai, J.F. Shriner, Jr., P.D. Cottle, D.A. Bromley, M. Morando and R.A. Ricci, Bull. Amer. Phys. Soc. 31 (1986) 839
- 1986SU18 T. Suzuki, T. Takaki and J.H. Koch, Nucl. Phys. A460 (1986) 607
- 1986SU1H Suter, Bull. Amer. Phys. Soc. 31 (1986) 1267
- 1986SW1A H.E. Swanson, V.J. Zeps, E.G. Adelberger, C.A. Gossett, J. Sromicki, W. Haerberli and P. Quin, Proc. Int. Symp., Heidelberg, Germany (1986) 400; Phys. Abs. 49238 (1987)
- 1986TA1E Taddeucci, J. Phys. Soc. Jpn. Suppl. 55 (1986) 156
- 1986TE01 P.K. Teng, B.H. Cottman, L. Ghedira, K. Min, P. Stoler, E.J. Winhold, M. Yamazaki, P.F. Yergin, A.M. Bernstein, K.I. Blomqvist et al., Phys. Lett. B177 (1986) 25
- 1986TR1C Truran and Livio, Astrophys. J. 308 (1986) 721
- 1986UL01 J.L. Ullmann, P.W.F. Alons, J.J. Kraushaar, J.H. Mitchell, R.J. Peterson, R.A. Ristinen, J.N. Knudson, J.R. Comfort, H.W. Baer, J.D. Bowman et al., Phys. Rev. C33 (1986) 2092
- 1986UT01 H. Utsunomiya, E.C. Deci, R.A. Blue, L.H. Harwood, R.M. Ronningen, K. Siwek-Wilczynska, J. Wilczynski and D.J. Morrissey, Phys. Rev. C33 (1986) 185
- 1986VA23 C.P.M. van Engelen, E.A. Bakkum, R.J. Meijer and R. Kamermans, Nucl. Phys. A457 (1986) 375
- 1986VDZY Vdovin et al., in Kharkov (1986) 290
- 1986VO1G Vogt, Proc. Int. Nucl. Phys. Conf., Harrogate, U.K., No. 68, Vol. 2 (1986) 23; Publ. by Inst. of Phys., Bristol, U.K.
- 1986WA13 E.K. Warburton, J. Phys. G12 (1986) 523
- 1986WE1C Westfall, Nucl. Phys. A447 (1986) 591c

- 1986WE1D Weller, J. Phys. Soc. Jpn. Suppl. 55 (1986) 113
- 1986WI04 D.H. Wilkinson, Nucl. Phys. A452 (1986) 296
- 1986WI10 R. Wittmann and N.C. Mukhopadhyay, Phys. Rev. Lett. 57 (1986) 1113
- 1986WO1A S.E. Woosley and T.A. Weaver, Ann. Rev. Astron. Astrophys. 24 (1986) 205
- 1986WU1C Wunsch, Majling and Zofka, Nucl. Phys. A450 (1986) 329c
- 1986WU1D Wunsch, Majling and Zofka, Czech. J. Phys. 36 (1986) 441
- 1986YA12 T. Yamaya, J.I. Hirota, K. Takimoto, S. Shimoura, A. Sakaguchi, S. Kubono, M. Sugitani, S. Kato, T. Suehiro and M. Fukada, Phys. Rev. C34 (1986) 2369
- 1986YA1Q Yamamoto, Nucl. Phys. A450 (1986) 275c
- 1986YA1R Yamaya et al., J. Phys. Soc. Jpn. Suppl. 55 (1986) 730, 732
- 1986ZA1A Zaikov et al., Nucl. Instr. Meth. Phys. Res. B17 (1986) 97
- 1986ZE04 N.S. Zelenskaya and A.K. Morzabaev, Izv. Akad. Nauk SSSR, Ser. Fiz. 50 (1986) 1840; Bull. Acad. Sci. USSR, Phys. Ser. 550 (1986) 170
- 1986ZE1A Zelevitskii and Mazepus, in Kharkov (1986) 147
- 1986ZI08 F. Zijderhand and C. van der Leun, Nucl. Phys. A460 (1986) 181
- 1987AB03 H. Abele, H.J. Hauser, A. Korber, W. Leitner, R. Neu, H. Plappert, T. Rohwer, G. Staudt, M. Strasser, S. Welte et al., Z. Phys. A326 (1987) 373
- 1987AB04 K. Abe, K. Maeda, T. Ishimatsu, T. Kawamura, T. Furukawa, H. Orihara and H. Ohnuma, Nucl. Phys. A466 (1987) 109
- 1987AB1J Ableev et al., JEPT Lett. 45 (1987) 596
- 1987AD07 E. Adamides, H.G. Bohlen, W. von Oertzen, M. Buenerd, J. Chauvin, D. Lebrun, J.Y. Hostachy, Ph. Martin, G. Perrin and P. de Saintignon, Nucl. Phys. A475 (1987) 598
- 1987AG1A Agakishiev et al., Sov. J. Nucl. Phys. 45 (1987) 852
- 1987AH1A Ahmad et al., in Panic (1987) 414
- 1987AJ02 F. Ajzenberg-Selove, Nucl. Phys. A475 (1987) 1
- 1987AJ1A F. Ajzenberg-Selove, Dubna (1987) 341
- 1987AL1B Altas, Astrophys. Space Sci. 134 (1987) 85
- 1987ALZW W.P. Alford, R. Helmer, J.W. Watson, C. Zafiratos, R. Abegg, A. Celler, S. El-Kateb, D. Frekers, O. Hausser, R. Henderson et al., Bull. Amer. Phys. Soc. 32 (1987) 1578
- 1987AN04 P.R. Andrews, B.M. Spicer, G.G. Shute, V.C. Officer, J.M.R. Wastell, H. Nann, Q. Li, A.D. Bacher, D.L. Friesel and W.P. Jones, Nucl. Phys. A468 (1987) 43
- 1987AR1C Arnould, Phil. Trans. Roy. Soc. (London) 323 (1987) 251
- 1987AR1H Arvieux et al., in Panic (1987) 296
- 1987AR1J Arai, Hasimoto and Fukui, Astron. Astrophys. 179 (1987) 17

- 1987AR1N Arnould et al., Nucl. Instrum. Meth. Phys. Res. B29 (1987) 120
- 1987AR25 K.P. Artemov, M.S. Golovkov, V.Z. Goldberg, V.P. Rudakov, I.N. Serikov and V.A. Timofeev, Yad. Fiz. 46 (1987) 55
- 1987AU04 S.M. Austin, N. Anantaraman and J.S. Winfield, Can. J. Phys. 65 (1987) 609
- 1987AU1A Audouze, J. Astrophys. Astron. 8 (1987) 147
- 1987BA2F Baer et al., in Panic 87 (1987) 352
- 1987BA2J W.A. Bardeen, R.D. Peccei and T. Yanagida, Nucl. Phys. B279 (1987) 401
- 1987BA2M Balsley et al., Nucl. Instrum. Meth. Phys. Res. B29 (1987) 37
- 1987BA2N Bard et al., Nucl. Instrum. Meth. Phys. Res. B29 (1987) 297
- 1987BA38 G.J. Balster, P.C.N. Crouzen, P.B. Goldhoorn, R.H. Siemssen and H.W. Wilschut, Nucl. Phys. A468 (1987) 93
- 1987BE1D Bertsch and Esbensen, Rep. Prog. Phys. 50 (1987) 607
- 1987BE1K Begnhanov et al., in Jurmala (1987) 53
- 1987BE1M Bereznoi, Kudryatsev and Soznic, in Yurmala (1987) 302
- 1987BE1P Bereznoi, Kudryatsev and Soznic, Dopov. Akad. Nauk. Ukr Rsr A-Fiz. 5 (1987) 54
- 1987BE25 I. Bergqvist, A. Brockstedt, L. Carlen, L.P. Ekstrom, B. Jakobsson, C. Ellegaard, C. Gaarde, J.S. Larsen, C. Goodman, M. Bedjidian et al., Nucl. Phys. A469 (1987) 648
- 1987BE55 I. Berceanu, I. Brancus, A. Buta, A. Demian, C. Grama, I. Lazar, I. Mihai, M. Petrascu, M. Petrovici, V. Simion et al., Rev. Roum. Phys. 32 (1987) 961
- 1987BE58 B. Berthier, R. Boisgard, J. Julien, J.M. Hisleur, R. Lucas, C. Mazur, C. Ng, M. Ribrag and C. Cerruti, Phys. Lett. B193 (1987) 417
- 1987BI20 T.S. Biro, K. Niita, A.L. De Paoli, W. Bauer, W. Cassing and U. Mosel, Nucl. Phys. A475 (1987) 579
- 1987BL04 R. Blendowske, T. Fliessbach and H. Walliser, Nucl. Phys. A464 (1987) 75
- 1987BL15 M. Bleszynski and R.J. Glauber, Phys. Rev. C36 (1987) 681
- 1987BL18 R. Blumel and K. Dietrich, Nucl. Phys. A471 (1987) 453
- 1987BL1D Blann, in Dubna (1987) 518
- 1987BO1B Bond and Luck, Astrophys. J. 312 (1987) 203
- 1987BO1D Boiko et al., in Jurmala (1987) 518
- 1987BO1E Boiko et al., in Jurmala (1987) 520
- 1987BO1K Bock et al., Mod. Phys. Lett. A2 (1987) 721
- 1987BO1U Bonani et al., Nucl. Instrum. Meth. Phys. Res. B29 (1987) 87
- 1987BU07 M. Burgel, H. Fuchs, H. Homeyer, G. Ingold, U. Jahnke and G. Thoma, Phys. Rev. C36 (1987) 90

- 1987BU12 L. Buchmann, J.M. D'Auria, J.D. King, G. Mackenzie, H. Schneider, R.B. Moore and C. Rolfs, Nucl. Instrum. Meth. Phys. Res. B26 (1987) 151
- 1987BU27 N.T. Burtebaev, A.D. Duisebaev, V.S. Sadkovskii and G.A. Feofilov, Izv. Akad. Nauk SSSR Ser. Fiz. 51 (1987) 615; Bull. Acad. Sci. USSR Phys. Ser. 51 (1987) 191
- 1987BUZP V.P. Bugrov, S.G. Kadmsky, V.I. Furman and Yu.M. Chuvilsky, Prog. and Theses, Proc.37th Ann. Conf. Nucl. Spectrosc. Struct. At. Nucl., Yurmala, (1987) 439
- 1987BUZR N. Burtebaev, S.A. Goncharov, A.S. Demyanova, G.N. Ivanov, Yu.V. Lyashko and A.A. Ogloblin, Prog. and Theses, Proc.37th Ann. Conf. Nucl. Spectrosc. Struct. At. Nucl., Yurmala, (1987) 327
- 1987CA14 G. Cantale, P. Bach, S. Degli-Agosti, Ph. Demierre, E. Heer, R. Hess, C. Lechanoine-Leluc, W.R. Leo, Y. Onel, Ph. Sorman et al., Helv. Phys. Acta 60 (1987) 398
- 1987CA20 J.R. Campbell, W.R. Falk, N.E. Davison, J. Knudson, R. Aryaeinejad and R. Tkachuk, Nucl. Phys. A470 (1987) 349
- 1987CO16 J. Cook, M.N. Stephens and K.W. Kemper, Nucl. Phys. A466 (1987) 168
- 1987CU1A Cummings and Stone, Bull. Amer. Phys. Soc. 32 (1987) 1066
- 1987CU1E Currie, Fletcher and Klouda, Nucl. Instrum. Meth. Phys. Res. B29 (1987) 346
- 1987DE02 A.C. Demiyanova, V.N. Bragin, A.A. Ogloblin, A.L. Lebedev, J.M. Bang, S.A. Goncharov, S.N. Ershov, F.A. Gareev and P.P. Korovin, Phys. Lett. B184 (1987) 129
- 1987DE43 H. De Vries, C.W. De Jager and C. De Vries, At. Data Nucl. Data Tables 36 (1987) 495
- 1987DOZY B. Doyle, R. Wittmann and N.C. Mukhopadhyay, Bull. Amer. Phys. Soc. 32 (1987) 1092
- 1987DU1G Duplessy et al., Nucl. Instrum. Meth. Phys. Res. B29 (1987) 223
- 1987DW1A R. Dwyer and P. Meyer, Astrophys. J. 322 (1987) 981
- 1987FA14 M.J. Facci and M.N. Thompson, Nucl. Phys. A465 (1987) 77
- 1987FE1A Feng et al., Chin. Phys. 7 (1987) 121
- 1987FU02 C. Funck and K. Langanke, Nucl. Phys. A464 (1987) 90
- 1987GA1E Gallant and Dmytrenko, Nucl. Instrum. Meth. Phys. Res. A257 (1987) 29
- 1987GE1A Gerbier et al., Phys. Rev. Lett. 59 (1987) 2535
- 1987GE1B Gelbke and Boal, Prog. Part. Nucl. Phys. 19 (1987) 33
- 1987GI1B Gismatullin et al., in Jurmala (1987) 519
- 1987GI1C W.R. Gibbs and B.F. Gibson, Ann. Rev. Nucl. Part. Sci. 37 (1987) 411
- 1987GO01 J. Gomez del Campo, D.E. DiGregorio, J.A. Biggerstaff, Y.D. Chan, D.C. Hensley, P.H. Stelson, D. Shapira and M.E. Ortiz, Phys. Rev. C35 (1987) 137
- 1987GO05 M. Gouweloos and M. Thies, Phys. Rev. C35 (1987) 631

- 1987GO08 A.N. Golzov, N.G. Goncharova and H.R. Kissener, Nucl. Phys. A462 (1987) 376
- 1987GO09 N.G. Goncharova, A.N. Golzov and H.R. Kissener, Nucl. Phys. A462 (1987) 367
- 1987GO17 P.L. Gonthier, B. Bouma, P. Harper, R. Ramaker, D.A. Cebra, Z.M. Koenig, D. Fox and G.D. Westfall, Phys. Rev. C35 (1987) 1946
- 1987GO1V C.D. Goodman, Can. J. Phys. 65 (1987) 549
- 1987GO1W Gove, Litherland and Purser, Nucl. Instrum. Meth. Phys. Res. B29 (1987) 437
- 1987GR1K Greiner, Symp. in Honor of D. Allan Bromley, Yale Univ. (1987) 66
- 1987GR20 A.M. Green and S. Wycech, Nucl. Phys. A467 (1987) 744
- 1987GU04 R.K. Gupta, S. Gulati, S.S. Malik and R. Sultana, J. Phys. G13 (1987) L27
- 1987GU1M Guo et al., High Energy Phys. Nucl. Phys. 11 (1987) 494
- 1987HA1E Harris and Lambert, Astrophys. J. 318 (1987) 868
- 1987HA1J P. Haapakoski, Mod. Phys. Lett. A2 (1987) 359
- 1987HA29 Q. Haider and L.C. Liu, Phys. Rev. C36 (1987) 1636
- 1987HE1F Hedges, Phil. Trans. Rov. Soc. London A323 (1987) 57
- 1987HE1G Heinemeier et al., Nucl. Instrum. Meth. Phys. Res. B29 (1987) 110
- 1987HE1H T.K. Hemmick, D. Elmore, P.W. Kubik, S.L. Olsen, T. Gentile, D. Nitz, D. Ciampa, H. Kagan, P. Haas, P.F. Smith et al., Nucl. Instrum. Meth. Phys. Res. B29 (1987) 389
- 1987HE22 R. Helmer, Can. J. Phys. 65 (1987) 588
- 1987HI05 D. Hilscher, H. Rossner, A. Gamp, U. Jahnke, B. Cheynis, B. Chambon, D. Drain, C. Pastor, A. Giorni, C. Morand et al., Phys. Rev. C36 (1987) 208
- 1987HO1J Hossain et al., Bull. Amer. Phys. Soc. 32 (1987) 1555
- 1987HO1L Ho, Chin. Phys. Lett. 4 (1987) 69
- 1987HU01 R.L. Huffman, J. Dubach, R.S. Hicks and M.A. Plum, Phys. Rev. C35 (1987) 1
- 1987IM02 A. Imanishi, S. Kato, T. Miyachi, Y. Takeuchi, K. Ukai, T. Ohmori, K. Takahashi, Y. Wada, Y. Morita and K. Kurita, Nucl. Phys. A462 (1987) 727
- 1987IR01 F. Irom, H.W. Baer, A.G. Bergmann, J.D. Bowman, P. Heusi, D.H. Fitzgerald, C.J. Seftor, M.E. Sadler, J.N. Knudson, W.J. Briscoe et al., Phys. Rev. C36 (1987) 1453
- 1987IV01 M. Ivascu, A. Sandulescu AND I. Silisteanu, Rev. Roum. Phys. 32 (1987) 549
- 1987JA06 B.V. Jacak, G.D. Westfall, G.M. Crawley, D. Fox, C.K. Gelbke, L.H. Harwood, B.E. Hasselquist, W.G. Lynch, D.K. Scott, H. Stocker et al., Phys. Rev. C35 (1987) 1751
- 1987JA07 W. Jaus and G. Rasche, Phys. Rev. D35 (1987) 3420
- 1987JA1G Jansen et al., Nucl. Instrum. Meth. Phys. Res. B29 (1987) 311

- 1987JO1B M.B. Johnson, Windsurfing the Fermi Sea, Vol. 2; Int. Conf. Symp. on Unified Concepts of Many-Body Problems, SUNY Stony Brook, NY 1986 (North-Holland, 1987) 275
- 1987KA39 T. Karapiperis and M. Kobayashi, Ann. Phys. 177 (1987) 1
- 1987KI1C Kissener, Rotter and Goncharova, Fortschr. Phys. 35 (1987) 277
- 1987KI1I Kieser et al., Nucl. Instrum. Meth. Phys. Res. B24-25 (1987) 667
- 1987KI1J Kishida et al., in Panic (1987) 278
- 1987KO01 E. Korkmaz, L.C. Bland, W.W. Jacobs, T.G. Throwe, S.E. Vigdor, M.C. Green, P.L. Jolivet and J.D. Brown, Phys. Rev. Lett. 58 (1987) 104
- 1987KO15 T. Kozik, J. Buschmann, K. Grotowski, H.J. Gils, N. Heide, J. Kiener, H. Klewe-Nebenius, H. Rebel, S. Zagromski, A.J. Cole et al., Z. Phys. A326 (1987) 421
- 1987KO1O Kobayashi and Karapiperis, in Panic (1987) 368
- 1987KO1Q Konijn et al., SIN Newsl. 19 (1987) 63
- 1987KO1T Kobayashi et al., Nucl. Instrum. Meth. Phys. Res. B29 (1987) 173
- 1987KO34 V.T. Koslowsky, J.C. Hardy, E. Hagberg, R.E. Azuma, G.C. Ball, E.T.H. Clifford, W.G. Davies, H. Schmeing, U.J. Schrewe and K.S. Sharma, Nucl. Phys. A472 (1987) 419
- 1987KR1O Kromer et al., Nucl. Instrum. Meth. Phys. Res. B29 (1987) 302
- 1987KU06 D. Kurath, Phys. Rev. C35 (1987) 2247
- 1987KU1C Kubozoe and Watanabe, Nucl. Instrum. Meth. Phys. Res. A255 (1987) 374
- 1987LA11 F.L. Lang, C.W. Werntz, C.J. Crannell, J.I. Trombka and C.C. Chang, Phys. Rev. C35 (1987) 1214
- 1987LE1E Leisi et al., Helv. Phys. Acta. 60 (1987) 316
- 1987LE24 P.R. Lewis, G.G. Shute, B.M. Spicer, V.C. Officer, P.R. Andrews and S.M. Banks, Nucl. Phys. A474 (1987) 499
- 1987LI30 R.A. Lindgren, M. Leuschner, B.L. Clausen, R.J. Peterson, M.A. Plum and F. Petrovich, Can. J. Phys. 65 (1987) 666
- 1987LO13 W.G. Love, K. Nakayama and M.A. Franey, Phys. Rev. Lett. 59 (1987) 1401
- 1987LO1D Love et al., Can. J. Phys. 65 (1987) 536
- 1987LO1E Lowe, Wallace and Sparks, Nucl. Instrum. Meth. Phys. Res. B29 (1987) 291
- 1987LU1B Lubovoi and Chitanava, in Yurmala (1987) 512
- 1987LY01 J.E. Lynn, S. Kahane and S. Raman, Phys. Rev. C35 (1987) 26
- 1987LY04 W.G. Lynch, Nucl. Phys. A471 (1987) 309c
- 1987MA1X Martoff, Science 237 (1987) 507

- 1987MA2C Malaney and Fowler, OAP-680, To be published in Origin and Distribution of the Elements (1987)
- 1987MA2E Martin, Nucl. Instrum. Meth. Phys. Res. B29 (1987) 179
- 1987MC1C Mckeown, Nucl. Instrum. Meth. Phys. Res. B24-25 (1987) 454
- 1987ME1B Mewaldt and Stone, Bull. Amer. Phys. Soc. 32 (1987) 1037
- 1987MI02 G.A. Miller, Phys. Rev. C35 (1987) 377
- 1987MI38 Mian, Phys. Rev. C35 (1987) 1463
- 1987MU03 J.A. Muzycka and B.I. Pustylnik, Sov. J. Nucl. Phys. 45 (1987) 57; Yad. Fiz. 45 (1987) 90
- 1987MU1B Murphy, Dermer and Ramaty, Astrophys. J. Suppl. 63 (1987) 721
- 1987NA01 M.N. Namboodiri, R.K. Choudhury, L. Adler, J.D. Bronson, D. Fabris, U. Garg, P.L. Gonthier, K. Hagel, D.R. Haenni, Y.W. Lui et al., Phys. Rev. C35 (1987) 149
- 1987NA04 J. Navarro and F. Roig, Nucl. Phys. A465 (1987) 628
- 1987NA1N Nakamura, Nakai and Ohishi, Nucl. Instrum. Meth. Phys. Res. B29 (1987) 355
- 1987NA1O Nakai et al., Nucl. Instrum. Meth. Phys. Res. B29 (1987) 228
- 1987OE1A Oeschger, Beer and Andree, Phil. Trans. Roy. Soc. (London) A323 (1987) 45
- 1987OR01 H. Orihara, M. Kabasawa, K. Furukawa, T. Kawamura, Y. Takahashi, A. Satoh, T. Niizeki, T. Nakagawa, K. Maeda, K. Ishii et al., Phys. Lett. B187 (1987) 240
- 1987OS1F Ostlucd, Nucl. Instrum. Meth. Phys. Res. B29 (1987) 286
- 1987PA01 D.J. Parker, J.J. Hogan and J. Asher, Phys. Rev. C35 (1987) 161
- 1987PA12 S.J. Padalino, K. Sartor, L.C. Dennis and K.W. Kemper, Phys. Rev. C35 (1987) 1692
- 1987PA1H B. Parker, K. Seth and R. Soundranayagam, Panic (1987) 356
- 1987PE19 C.F. Perdrisat, V. Punjabi, C. Lyndon, J. Yonnet, R. Beurtey, M. Boivin, A. Boudard, J.P. Didelez, R. Frascaria, T. Reposeur et al., Phys. Rev. Lett. 59 (1987) 2840
- 1987PE1C Penionshkevich, in Dubna 86 (1987) 364
- 1987PO05 H. Poth, H. Barth, G. Buche, A.D. Hancock, H. Koch, Th. Kohler, A. Kreissl, U. Raich, D. Rohmann, A. Wolf et al., Nucl. Phys. A466 (1987) 667
- 1987PO1F Poplavskii, in Yurmala (1987) 159
- 1987PO1H Povh, Prog. Part. Nucl. Phys. 18 (1987) 183
- 1987PO1K Polach, Nucl. Instrum. Meth. Phys. Res. B29 (1987) 415
- 1987PO1L Poenaru, Ivascu and Mazilu, Stud. Cercet. Foz. (Romania) 39 (1987) 459
- 1987PR1A Prapkos, Arnould and Arcoragi, Astrophys. J. 315 (1987) 209
- 1987PR1E Price and Barwick, Dubna (1987) 190

- 1987RA01 S. Raman, C.H. Malarkey, W.T. Milner, C.W. Nestor, Jr. and P.H. Stelson, *At. Data Nucl. Data Tables* 36 (1987) 1
- 1987RA15 J. Rapaport, D. Wang, J.A. Carr, F. Petrovich, C.C. Foster, C.D. Goodman, C. Gaarde, J. Larsen, C.A. Goulding, T.N. Taddeucci et al., *Phys. Rev. C* 36 (1987) 500
- 1987RA1D R. Ramaty and R.J. Murphy, *Space Sci. Rev.* 45 (1987) 213
- 1987RA32 J. Rapaport, *Can. J. Phys.* 65 (1987) 574
- 1987RE01 D.A. Resler, R.O. Lane and H.D. Knox, *Phys. Rev. C* 35 (1987) 855
- 1987RE03 B.A. Remington, M. Blann and G.F. Bertsch, *Phys. Rev. C* 35 (1987) 1720
- 1987RE11 B.A. Remington and M. Blann, *Phys. Rev. C* 36 (1987) 1387
- 1987RE1H Reedy, *Nucl. Instrum. Meth. Phys. Res. B* 29 (1987) 251
- 1987RI03 J. Richert and P. Wagner, *Nucl. Phys. A* 466 (1987) 132
- 1987RO10 G. Royer, Y. Raffray, A. Oubahadou and B. Remaud, *Nucl. Phys. A* 466 (1987) 139
- 1987RO23 K. Rohrich, G. Kobschall, C. Reifferscheid, C. Schmitt, V.H. Walther and K. Weinand, *Nucl. Phys. A* 475 (1987) 761
- 1987ROZY S.H. Rokni, H.W. Baer, J.D. Bowman, F. Irom, M.J. Leitch, J. Alster, E. Piassetzky, J.R. Comfort, J.N. Knudson, B.L. Clausen et al., *Bull. Amer. Phys. Soc.* 32 (1987) 1119
- 1987RU1C Rubchenya, Eismont and Yavshitz, in *Dubna* (1987) 200
- 1987RU1D Rubchenya, Chechev and Yavshits, *Priroda (USSR)* 6 (1987) 22
- 1987SA15 H. Sagawa and H. Toki, *J. Phys. G* 13 (1987) 453
- 1987SA25 M.G. Saint-Laurent, *Nucl. Instrum. Meth. Phys. Res. B* 26 (1987) 273
- 1987SC11 L. Schmieder, D. Hilscher, H. Rossner, U. Jahnke, M. Lehmann, K. Ziegler and H.-H. Knitter, *Nucl. Instrum. Meth. Phys. Res. A* 256 (1987) 457
- 1987SE1D J.P.F. Sellschop, *Nucl. Instrum. Meth. Phys. Res. B* 29 (1987) 439
- 1987SH04 Y.-J. Shi and W.J. Swiatecki, *Nucl. Phys. A* 464 (1987) 205
- 1987SH1A Shen et al., *Proc. Beijing Int. Symp. on Phys. at Tandem 1986* (1987) 293
- 1987SH23 W. Shen, Y. Zhu, W. Zhan, Z. Guo, S. Yin, W. Qiao and X. Yu, *Nucl. Phys. A* 472 (1987) 358
- 1987SI1D Simpson, Earwaker and Khan, *Nucl. Instrum. Meth. Phys. Res. B* 24-25 (1987) 701
- 1987SL1A Slota et al., *Radiocarbon* 29 (1987) 303
- 1987SN01 K. Sneppen, *Nucl. Phys. A* 470 (1987) 213
- 1987ST01 G.S.F. Stephans, R.V.F. Janssens, D.G. Kovar and B.D. Wilkins, *Phys. Rev. C* 35 (1987) 614
- 1987SU06 T. Suzuki, D.F. Measday and J.P. Roalsvig, *Phys. Rev. C* 35 (1987) 2212

- 1987SU17 B.-N. Sung, K. Shoda, A. Kagaya, S. Toyama, M. Torikoshi, O. Sasaki, T. Kobayashi and H. Tsubota, Nucl. Phys. A473 (1987) 705
- 1987SU1G Sukhoruchkin and Tyukavina, in Yurmala (1987) 223
- 1987TA07 Y. Tagishi, Y. Aoki, M. Kurokawa, T. Murayama, T. Sakai, M. Takei, M. Tomizawa and K. Yagi, Phys. Rev. C35 (1987) 1153
- 1987TA13 T.N. Taddeucci, C.A. Goulding, T.A. Carey, R.C. Byrd, C.D. Goodman, C. Gaarde, J. Larsen, D. Horen, J. Rapaport and E. Sugarbaker, Nucl. Phys. A469 (1993) 125
- 1987TA1K Taylor, Nucl. Instrum. Meth. Phys. Res. B29 (1987) 159
- 1987TA22 T.N. Taddeucci, Can. J. Phys. 65 (1987) 557
- 1987TE1D Ter Nersesyants, Yurmala (1987) 540
- 1987TH04 A. Thiel, W. Greiner, J.Y. Park and W. Scheid, Phys. Rev. C36 (1987) 647
- 1987VA1S van der Borg et al., Nucl. Instrum. Meth. Phys. Res. B29 (1987) 143
- 1987VA26 A.G.M. van Hees, A.A. Wolters and P.W.M. Glaudemans, Phys. Lett. B196 (1987) 19
- 1987VD03 A.I. Vdovin, A.V. Golovin and I.I. Loshchakov, Yad. Fiz. 45 (1987) 1595; Sov. J. Nucl. Phys. 45 (1987) 989
- 1987VD1A A.I. Vdovin, A.V. Golovin and I.I. Loschakov, Sov. J. Part. Nucl. 18 (1987) 573
- 1987VE1D Vetoshkin et al., in Yurmala (1987) 387
- 1987VI02 F. Videbaek, S.G. Steadman, G.G. Batrouni and J. Karp, Phys. Rev. C35 (1987) 2333
- 1987VI13 S.E. Vigdor, W.W. Jacobs, E. Korkmaz, Phys. Rev. Lett. 58 (1987) 840
- 1987WA1L Walsh and Roy, Astrophys. J. 319 (1987) L57
- 1987WE1C Weneser and Friedlander, Science 235 (1987) 755
- 1987WI09 J.S. Winfield, N. Anantaraman, S.M. Austin, Ziping Chen, A. Galonsky, J. van der Plicht, H.-L. Wu, C.C. Chang and G. Ciangaru, Phys. Rev. C35, 1734 (1987)
- 1987YA16 Yu.P. Yakovlev, Yad. Fiz. 46 (1987) 459; Sov. J. Nucl. Phys. 46 (1987) 244
- 1987YA1J Yamazaki et al., in Panic (1987) 672
- 1987YI1A S.-Z. Yin, Y.-T. Zhu, W.-Q. Shen, Z.-Y. Guo, W.-L. Zhan, W.-M. Qiao, E.-C. Wu and Z.-H. Zheng, Phys. Energ. Fortis and Phys. Nucl. 11 (1987) 259
- 1987ZA1D Zaika and Magal, in Yurmala (1987) 410
- 1987ZEZZ V.S. Zeps, E.G. Adelberger, A. Garcia, C.A. Gossett, H.E. Swanson, W. Haeberli, P.A. Quin and J. Sromicki, Bull. Amer. Phys. Soc. 32 (1987) 1061
- 1987ZI04 M. Zielinski, W.Y. Baek, K. Bharuth-Ram, D. Gassen and W. Neuwirth, Phys. Rev. A36 (1987) 5170
- 1988AB13 V.G. Ableev, L. Vizireva, V.I. Volkov, S.V. Dzhmukhadze, S.A. Zaporozhets, A.D. Kirillov, A.P. Kobushkin, V.I. Kotov, B. Kuhn, P.K. Manyakov et al., Pisma Zh. Eksp. Teor. Fiz. 47 (1988) 558; JETP Lett. 47 (1988) 649

- 1988AD1B Adodin et al., Baku (1988) 333
- 1988AJ01 F. Ajzenberg-Selove, Nucl. Phys. A490 (1988) 1
- 1988AL1F Aleksandrov et al., 38th Meeting on Nucl. Spectroscopy and the Structure of the At. Nucl., Baku, USSR, 12-14 April 1988 (Nauka, 1988) 353
- 1988AL1G Aleksandrov et al., in Baku (1988) 377
- 1988AL1H Alizade, in Baku (1988) 418
- 1988AL1J I.M. Al-Khamiesi, B.K. Kerimov and M.Ya. Safin, Acta Phys. Pol. B19 (1988) 213
- 1988AL1K M.M. Al-Kofahi, A.B. Hallak, H.A. Al-Juwair and A.K. Saafin, Bull. Amer. Phys. Soc. 33 (1988) 1730
- 1988AN06 N. Anantaraman, S.M. Austin and J.S. Winfield, Nucl. Phys. A482 (1988) 331c
- 1988AN19 A. Antonov, V.A. Vesna, Yu.M. Gledenov, T.S. Zvarova, V.M. Lobashev, I.S. Okunev, Yu.P. Popov, Kh. Rigol, L.M. Smotritsky and E.V. Shulgina, Yad. Fiz. 48 (1988) 305; Sov. J. Nucl. Phys. 48 (1988) 193
- 1988AP1A J.H. Applegate, Phys. Rep. 163 (1988) 141
- 1988AP1B Applegate, in AIP Conf. Proc. 176 (1988) 988
- 1988AR23 K.P. Artemov, A.L. Vetoshkin, M.S. Golovkov, V.Z. Goldberg, V.P. Rudakov, I.N. Serikov and V.A. Timofeev, Yad. Fiz. 48 (1988) 1228
- 1988AS1C Asahi et al., Nucl. Phys. A488 (1988) 83c
- 1988AU1D Auerbach, AIP Conf. Proc. 163 (1988) 34
- 1988AU1E Austin, MSUCL 659 (1988)
- 1988AY03 S. Ayik, D. Shapira and B. Shivakumar, Phys. Rev. C38 (1988) 2610
- 1988BA01 F. Barranco, R.A. Broglia and G.F. Bertsch, Phys. Rev. Lett. 60 (1988) 507
- 1988BA2D Baer et al., in AIP Conf. Proc. 163 (1988) 67
- 1988BA2R Baer, AIP Conf. Proc. 176 (1988) 589
- 1988BA37 I.S. Batkin, I.V. Kopytin and M.I. Berkman, Yad. Fiz. 47 (1988) 1602
- 1988BA86 Bahcall and Ulrich, Rev. Mod. Phys. 60 (1988) 297
- 1988BE02 A.V. Belozyorov, C. Borcea, Z. Dlouhy, A.M. Kalinin, Nguyen Hoai Chau and Yu.E. Penionzhkevich, Nucl. Phys. A477 (1988) 131
- 1988BE1B J. Beer, U. Siegenthaler, G. Bonani, R.C. Finkel, H. Oeschger, M. Suter and W. Wolfli, Nature 331 (1988) 675
- 1988BE56 A.V. Belozorov, K.C. Borcea, J. Wincour, M. Lewitowicz, N.H. Chau, Yu.E. Penionzhkevich, N.K. Skobelev and A. Chasha, Izv. Akad. Nauk SSSR 52 (1988) 2171; Bull. Acad. Sci. USSR, Phys.Ser. 52 (1988) 90

- 1988BEYJ A.V. Belozerov, K. Borch, I. Vintsour, Z. Dlougy, N.K. Tyau and Yu.Eh. Penionzhkevich, in Baku (1988) 380
- 1988BI11 N. Bischof, W. Tiereth, I. Weitzenfelder, H. Voit, W. von Oertzen and H.H. Wolter, Nucl. Phys. A490 (1988) 485
- 1988BI1A Bi, Mod. Phys. Lett. A3 (1988) 653
- 1988BL11 R. Blendowske and H. Walliser, Phys. Rev. Lett. 61 (1988) 1930
- 1988BO20 H.G. Bohlen, B. Gebauer, D. Kolbert, W. von Oertzen, E. Stiliaris, M. Wilpert and T. Wilpert, Z. Phys. A330 (1988) 227
- 1988BO46 J. Bogdanowicz, Nucl. Phys. A479 (1988) 323c
- 1988BR26 J.D. Brown, L.K. Herold, K.E. Luther, A.A. Middleton, M.L. Pitt, D. Barker and S.M. Aziz, Phys. Rev. C38 (1988) 1958
- 1988BU01 L. Buchman, J.M. D'auria and P. McCorquodale, Astrophys. J. 324 (1988) 953
- 1988CA06 G. Caskey, L. Heilbronn, B. Remington, A. Galonsky, F. Deak, A. Kiss and Z. Seres, Phys. Rev. C37 (1988) 696
- 1988CA26 G.R. Caughlan and W.A. Fowler, At. Data Nucl. Data Tables 40 (1988) 283
- 1988CA27 G. Cardella, M. Papa, G. Pappalardo, F. Rizzo, A. De Rosa, G. Inghima, M. Sandoli, G. Fortuna, G. Montagnoli, A.M. Stefanini et al., Nucl. Phys. A482 (1988) 235c
- 1988CL03 B.L. Clausen, R.J. Peterson and R.A. Lindgren, Phys. Rev. C38 (1988) 589
- 1988CL04 N.M. Clarke, P.R. Hayes, M.B. Becha, K.I. Pearce, R.J. Griffiths, J.B.A. England, L. Zybert, C.N. Pinder, G.M. Field and R.S. Mackintosh, J. Phys. G14 (1988) 1399
- 1988CO05 S.F. Collins, G.G. Shute, B.M. Spicer, V.C. Officer, D.W. Devins, D.L. Friesel and W.P. Jones, Nucl. Phys. A481 (1988) 494
- 1988CUZX A.C. Cummings, E.R. Christian, E.C. Stone, Bull. Amer. Phys. Soc. 33 (1988) 1069, HM12
- 1988DE34 A.S. Demianova, A.A. Ogloblin, Yu.V. Lyashko, V.V. Adodin, N. Burtebaev, S.N. Ershov, F.A. Gareev, P.P. Korovin, J.M. Bang, S.A. Goncharov et al., Phys. Rev. C38 (1988) 1975
- 1988DE47 A.S. Demyanova, A.A. Ogloblin, S.N. Ershov, F.A. Gareev, P.P. Korovin, S.A. Goncharov, U.V. Lyashko, V.V. Adonin, N. Burtebaev and J.M. Bang, Nucl. Phys. A482 (1988) 383c
- 1988DI02 S.S. Dietrich and B.L. Berman, At. Data Nucl. Data Tables 38 (1988) 199
- 1988DO1D Donahue, Bull. Amer. Phys. Soc. 33 (1988) 1752
- 1988DRZZ J.R. Drummond, F.P. Brady, C.M. Castaneda, E.L. Hjort, B. McEachern, J.L. Romero and D.S. Sorenson, Bull. Amer. Phys. Soc. 33 (1988) 1568
- 1988DU04 E.I. Dubovoy and G.I. Chitanava, Yad. Fiz. 47 (1988) 75

- 1988DU09 J.P. Dufour, R. Del Moral, F. Hubert, D. Jean, M.S. Pravikoff, A. Fleury, A.C. Mueller, K.-H. Schmidt, K. Summerer, E. Hanelt et al., Phys. Lett. B206 (1988) 195
- 1988DU1B Dufour, Parker and Heinze, Astrophys. J. 327 (1988) 859
- 1988DU1G Dufour, Garnett and Shields, Astrophys. J. 332 (1988) 752
- 1988EL1C Elmore, Bull. Amer. Phys. Soc. 33 (1988) 1790
- 1988EP1A Epstein, Colgate and Haxton, Phys. Rev. Lett. 61 (1988) 2038
- 1988FL1A Florescu, Holan and Sandulescu, Rev. Roum. Phys. 33 (1988) 243
- 1988GA12 S.B. Gazes, H.R. Schmidt, Y. Chan, E. Chavez, R. Kamermans and R.G. Stokstad, Phys. Rev. C38 (1988) 712
- 1988GA1N Gareev et al., Sov. J. Part. Nucl. 19 (1988) 373
- 1988GI02 T.A. Girard, A.S. Carnoy, J. Deutsch, R. Prieels and M.L. Schmit, Z. Phys. A330 (1988) 51
- 1988GIZU Yu.R. Gismatullin, A.A. Melentev, V.I. Ostroumov, A.M. Petukhov and M.A. Stalevich, in Baku (1988) 293
- 1988GO12 M. Gonin, J.P. Coffin, G. Guillaume, F. Jundt, P. Wagner, P. Fintz, B. Heusch, A. Malki, A. Fahli, S. Kox et al., Phys. Rev. C38 (1988) 135
- 1988GO1H Goryonov et al., in Baku (1988) 367
- 1988GO1M Gossett, Bull. Amer. Phys. Soc. 33 (1988) 1691
- 1988GO1R Gokalp and Boz, Doga Turk Fiz. Astrofiz. Derg. 12 (1988) 141
- 1988GOZM N.G. Goncharova and V.Ya. Spevak, Prog. and Theses, Proc. 38th Ann. Conf. Nucl. Spectrosc. Struct. At. Nucl., Baku (1988) 140
- 1988GU1C Guseninov et al., in Baku (1988) 258
- 1988HA14 A.C. Hayes, S. Chakravarti, D. Dehnhard, P.J. Ellis, D.B. Holtkamp, L.-P. Lung, S.J. Seestrom-Morris, H. Baer, C.L. Morris, S.J. Greene et al., Phys. Rev. C37 (1988) 1554
- 1988HA37 Q. Haider and L.C. Liu, Phys. G14 (1988) 1527; Corrigendum J. Phys. G15 (1989) 934
- 1988HA43 D. Hahn and H. Stocker, Nucl. Phys. A476 (1988) 718
- 1988HAZS B.A. Harmon, Y.D. Chan, A. Dacal, D.E. Digregorio, R. Knop, M.E. Ortiz, J. Pouliot, R.G. Stokstad, C. Moisan, L. Potvin et al., Bull. Amer. Phys. Soc. 33 (1988) 1572
- 1988HE12 R. Heuer, B. Muller, H. Stocker and W. Greiner, Z. Phys. A330 (1988) 315
- 1988HE1G E.M. Henley, Can. J. Phys. 66 (1988) 554
- 1988HE1I Hennino, in AIP Conf. Proc. 176 (1988) 663
- 1988HO06 Y.K. Ho and C. Coceva, J. Phys. G14 (1988) S207

- 1988HO1E Ho, *Chin. Phys.* 8 (1988) 738
- 1988HU04 G.M. Huber, G.J. Lolos, R.D. Bent, K.H. Hicks, P.L. Walden, S. Yen, X. Aslanoglou, E.G. Auld and W.R. Falk, *Phys. Rev. C*37 (1988) 1161
- 1988HU06 G.M. Huber, G.J. Lolos, K.H. Hicks, P.L. Walden, S. Yen, R.D. Bent, W.R. Falk and E.G. Auld, *Phys. Rev. C*37 (1988) 2051
- 1988HU11 G.M. Huber, G.J. Lolos, K.M. Furutani, W.R. Falk, R.D. Bent, K.H. Hicks, P.L. Walden and S. Yen, *Phys. Rev. C*38 (1988) 1304
- 1988ILZZ D. Ila and G.H.R. Kegel, *Bull. Amer. Phys. Soc.* 33 (1988) 1731, PA'3
- 1988IV1C Ivascu et al., *Rev. Roum. Phys.* 33 (1988) 675
- 1988JO1B G. A. Jones, *Interactions and Structures in Nuclei, Proc. in Honor of D.H. Wilkinson, Sussex, 9/87, A. Hilger Publ.* (1988) 9
- 1988JO1D Jongen, *Bull. Amer. Phys. Soc.* 33 (1988) 1712
- 1988JU1B Jull, *Bull. Amer. Phys. Soc.* 33 (1988) 1753
- 1988KA1L Kademsky, Lukyanovich, Rudchik and Skalnitsky, in *Baku* (1988) 462
- 1988KI06 A. Kiss, F. Deak, Z. Seres, G. Caskey, A. Galonsky, L. Heilbronn and B. Remington, *Phys. Rev. C*38 (1988) 170
- 1988KI1C Kiptily, in *Baku* (1988) 534
- 1988KO1V Koch, *AIP Conf. Proc.* 176 (1988) 527
- 1988KR11 L. Kraus, A. Boucenna, I. Linck, B. Lott, R. Rebmeister, N. Schulz, J.C. Sens, M.C. Mermaz, B. Berthier, R. Lucas et al., *Phys. Rev. C*37 (1988) 2529
- 1988KR1G Krombel and Wiedenbeck, *Astrophys. J.* 328 (1988) 940
- 1988KW02 E. Kwasniewicz and J. Kisiel, *Acta Phys. Pol.* B19 (1988) 141
- 1988KY1A Kyle, in *AIP Conf. Proc.* 163 (1988) 289
- 1988LA03 J. Lang, J. Liechti, R. Muller, P.A. Schmelzbach, J. Smyrski, M. Godlewski, L. Jarczyk, A. Stralkowski and H. Witala, *Nucl. Phys.* A477 (1988) 77
- 1988LE08 K.T. Lesko, E.B. Norman, R.-M. Larimer, S. Kuhn, D.M. Meekhof, S.G. Crane and H.G. Bussell, *Phys. Rev. C*37 (1988) 1808
- 1988LE1G M.J. Leitch, *Bull. Amer. Phys. Soc.* 33 (1988) 1548
- 1988LO01 J.L. Lopez and L. Durand, *Phys. Rev. C*37 (1988) 535
- 1988LU02 K.E. Luther, J.D. Brown and R.T. Kouzes, *Phys. Rev. C*38 (1988) 529
- 1988LY1B Lynch, *Nucl. Phys.* A488 (1988) 359c
- 1988MA1G Majling et al., *Phys. Lett.* B202 (1988) 489
- 1988MA1U R.A. Malaney and W.A. Fowler, *Astrophys. J.* 333 (1988) 14

- 1988MC01 K.G. McNeill, A.D. Bates, R.P. Rassool, E.A. Milne and M.N. Thompson, Phys. Rev. C37 (1988) 1403
- 1988MCZT V. McLane, C.L. Dunford and P.F. Rose, Neutron Cross Sections, Vol. 2 (Academic Press, New York, 1988)
- 1988ME10 M.C. Mermaz, Rev. Roum. Phys. 33 (1988) 739
- 1988MI1G D. Mikolas, B.A. Brown, W. Benenson, Y. Chen, M.S. Curtin, L.H. Harwood, E. Kashy, J.A. Nolen, Jr., M. Samuel, B. Sherrill et al., AIP Conf. Proc. 164 (1988) 708
- 1988MI1K Miller, AIP Conf. Proc. 163 (198) 438
- 1988MI28 M. Mishra, M. Satpathy and L. Satpathy, J. Phys. G14 (1988) 1115
- 1988MO11 T. Motobayashi, S. Satoh, H. Sakai, N. Matsuoka, T. Saito, T. Noro, K. Hosono, A. Okihana, M. Ishihara, H. Okamura et al., J. Phys. G14 (1988) L137
- 1988MO1L Motoba, Itonaga and Bando, Nucl. Phys. A489 (1988) 683
- 1988OH04 N. Ohtsuka, Nucl. Phys. A480 (1988) 513
- 1988OS1A Oset et al., AIP Conf. Proc. 163 (1988) 100
- 1988PA06 G.E. Parnell, D.J. Ernst and D.R. Giebink, Phys. Lett. B205 (1988) 135
- 1988PA1K Patnaik et al., Bull. Amer. Phys. Soc. 33 (1988) 2188
- 1988PAZS S.J. Padalino, T.G. Declerk, M.A. Putnam, J.A. Constable, L.C. Dennis, K. Sartor, R.A. Zingarelli and R.C. Kline, Bull. Amer. Phys. Soc. 33 (1988) 1562
- 1988PO1F Ponkratenko, Nemets and Rudchik, in Baku (1988) 365
- 1988POZS N.A.F.M. Poppelier, J.H. de Vries, A.A. Wolters and P.W.M. Glaudemans, AIP Conf. Proc. 164 (1988) 334
- 1988POZZ J. Pouliot, Y.D. Chan, A. Dacal, B.A. Harmon, R. Knop, M.E. Ortiz, E. Plagnol, R.G. Stokstad, C. Moisan, L. Potvin et al., Bull. Amer. Phys. Soc. 33 (1988) 1179
- 1988PR02 M. Prakash, P. Braun-Munzinger, J. Stachel and N. Alamanos, Phys. Rev. C37 (1988) 1959
- 1988PR1B Price, AIP Conf. Proc. 164 (1988) 800
- 1988PU1A Purser et al., Nucl. Instrum. Meth. Phys. Res. B35 (1988) 284
- 1988RA08 L. Ray, G.W. Hoffmann, M.L. Barlett, J.D. Lumpe, B.C. Clark, S. Hama and R.L. Mercer, Phys. Rev. C37 (1988) 1169; Erratum Phys. Rev. C39 (1989) 2089
- 1988RA10 S. Raman, S. Kahane and J.E. Lynn, J. Phys. G14, Supplement (1988) S223
- 1988RA37 C.R. Rao, K. Narasimha Murty, Satya Prakash and T. Sayibaba, Z. Phys. A331 (1988) 401
- 1988RO03 S.H. Rokni, H.W. Baer, A.G. Bergmann, J.D. Bowman, F. Irom, M.J. Leitch, C.J. Seftor, J. Alster, E. Piassetzky, B.L. Clausen et al., Phys. Lett. B202 (1988) 35
- 1988RO04 C. Rolfs, J. Phys. G14, Supplement (1988) S323

- 1988RO17 M. Roy-Stephan, Nucl. Phys. A488 (1988) 187c
- 1988RO1F Romanovsky et al., Baku (1988) 578
- 1988RO1L Rolfs, Bull. Amer. Phys. Soc. 33 (1988) 1712
- 1988RO1M Roos, in AIP Conf. Proc. 163 (1988) 210
- 1988RU01 V.A. Rubchenya and S.G. Yavshits, Z. Phys. A329 (1988) 217
- 1988SA19 H. Sato, Phys. Rev. C37 (1988) 2902
- 1988SA1X A. Sandulescu, Rev. Roum. Phys. 33 (1988) 909
- 1988SA2A Savage, Filippone and Mitchell, Phys. Rev. D37 (1988) 1134
- 1988SA35 A. Sandulescu, Phys. Scr. T23 (1988) 43
- 1988SC14 R.A. Schumacher, P.A. Amaudruz, C.H.Q. Ingram, U. Sennhauser, H. Breuer, N.S. Chant, A.E. Feldman, B.S. Flanders, F. Khazaie, D.J. Mack et al., Phys. Rev. C38 (1988) 2205
- 1988SE1A K.K. Seth, Nucl. Phys. A478 (1988) 591c
- 1988SH03 B. Shivakumar, D. Shapira, P.H. Stelson, S. Ayik, B.A. Harmon, K. Teh and D.A. Bromley, Phys. Rev. C37 (1988) 652
- 1988SH29 G. Shanmugam and B. Kamalaharan, Phys. Rev. C38 (1988) 1377
- 1988SI01 J.D. Silk, H.D. Holmgren, D.L. Hendrie, T.J.M. Symons, G.D. Westfall, P.H. Stelson, S. Raman, R.L. Auble, J.R. Wu and K. Van Bibber, Phys. Rev. C37 (1988) 158
- 1988SI08 P.J. Simmonds, K.I. Pearce, P.R. Hayes, N.M. Clarke, R.J. Griffiths, M.C. Mannion and C.A. Ogilvie, Nucl. Phys. A482 (1988) 653
- 1988ST1D R.L. Stern, F.D. Becchetti, T. Casey, J.W. Janecke, P.M. Lister, W.Z. Liu, D.G. Kovar, R.V.F. Janssens, M.F. Vineyard, W.R. Phillips et al., AIP Conf. Proc. 164 (1988) 845
- 1988SU1E Suter, Bull. Amer. Phys. Soc. 33 (1988) 1752
- 1988TA10 I. Tanihata, T. Kobayashi, O. Yamakawa, S. Shimoura, K. Ekuni, K. Sugimoto, N. Takahashi, T. Shimoda and H. Sato, Phys. Lett. B206 (1988) 592
- 1988TA13 H. Takai, K. Koide, A. Bairrio Nuevo, Jr. and O. Dietzsch, Phys. Rev. C38 (1988) 741
- 1988TA1N Tanihata, Nucl. Phys. A488 (1988) 113c
- 1988TE03 W. Terlau, M. Burgel, A. Budzanowski, H. Fuchs, H. Homeyer, G. Roschert, J. Uckert and R. Vogel, Z. Phys. A330 (1988) 303
- 1988TI06 L. Tiator, J. Vesper, D. Drechsel, N. Ohtsuka and L.E. Wright, Nucl. Phys. A485 (1988) 565
- 1988TR1C J.W. Truran, AIP Conf. Proc. 16 (1988) 543
- 1988UT02 H. Utsunomiya and R.P. Schmitt, Nucl. Phys. A487 (1988) 162

- 1988VA03 A.G.M. van Hees, A.A. Wolters and P.W.M. Glaudemans, Nucl. Phys. A476 (1988) 61
- 1988VD1B Vdovin et al., Baku (1988) 275
- 1988VO08 W. von Oertzen, E. Adamides, M. Buenerd, J. Chauvin, D. Lebrun, J.Y. Hostachy, G. Duhamel, Ph. Martin, G. Perrin and P. de Saintignon, Nucl. Phys. A487 (1988) 195
- 1988WA1I Wanke and Dreibus, Phil. Trans. Roy. Soc. London A325 (1988) 545
- 1988WA1Q Watson, Nucl. Instrum. Meth. Phys. Res. B40-41 (1988) 481
- 1988WAZX T.F. Wang, K.E. Rehm, S.J. Sanders, C.N. Davids, B.G. Glagola, R. Holzmann, W.C. Ma, P.V. Magnus, P.D. Parker and M. Smith, Bull. Amer. Phys. Soc. 33 (1988) 1564
- 1988WO04 A.A. Wolters, A.G.M. van Hees and P.W.M. Glaudemans, Europhys. Lett. 5 (1988) 7
- 1988WO09 J.M. Wouters, R.H. Kraus, Jr., D.J. Vieira, G.W. Butler and K.E.G. Lobner, Z. Phys. A331 (1988) 229
- 1988WO10 C.L. Woods, F.C. Barker, W.N. Catford, L.K. Fifield and N.A. Orr, Aust. J. Phys. 41 (1988) 525
- 1988WRZZ L.E. Wright, Y. Jin and C. Bennhold, Bull. Amer. Phys. Soc. 33 (1988) 902
- 1988YA06 T. Yamaya, O. Satoh, S.M. Morita, K. Kotajima, K. Hasegawa, T. Shinozuka and M. Fujioka, Phys. Rev. C37 (1988) 2585
- 1988YA10 Yanhe Jin, L.E. Wright, C. Bennhold and D.S. Onley, Phys. Rev. C38 (1988) 923
- 1988YU04 Z.-Q. Yu, C.-H. Cai, W.-H. Ma and S.-P. Zhao, Phys. Rev. C38 (1988) 272
- 1988ZA1A Zaika and Magal, Ukr. Fiz. Zh. SSSR 33 (1988) 965
- 1988ZE1B Zeps et al., AIP Conf. Proc. 176 (1988) 1098
- 1989AB1J Abia and Rebolo, Astrophys. J. 347 (1989) 186
- 1989AG1A Aguer et al., Tokyo (1988) 17
- 1989AJ1A F. Ajzenberg-Selove, in Mikolajki (1989) 1
- 1989AL04 W.P. Alford, R. Helmer, R. Abegg, A. Celler, D. Frekers, O. Hausser, R. Henderson, K. Hicks, K.P. Jackson, R. Jeppesen et al., Phys. Rev. C39 (1989) 1189
- 1989AM01 K. Amos, D. Koetsier and D. Kurath, Phys. Rev. C40 (1989) 374
- 1989AM02 K. Amos, L. Berge and D. Kurath, Phys. Rev. C40 (1989) 1491
- 1989AM05 K. Amos and J. Raynal, Aust. J. Phys. 42 (1989) 591
- 1989AN12 I. Angeli, Z. Phys. A334 (1989) 377
- 1989AR1G Arnould et al., Tokyo (1988) 287
- 1989AR1H A. Arima, Proc. Int. Symp. on Heavy Ion Phys. and Nucl. Astrophys. Problems, Tokyo, July 21-23, 1988 (1989) 407

- 1989AR1J M. Arnould, F. Baeten, D. Darquennes, Th. Delbar, C. Dom, M. Huyse, Y. Jongen, P. Leleux, M. Lacroix, P. Lipnik et al., Nucl. Instrum. Meth. Phys. Res. B40-41 (1989) 498
- 1989AR1M Artemov et al., Tashkent (1989) 568
- 1989AR1Q Arnould et al., Nucl. Instrum. Meth. Phys. Res. A282 (1989) 99
- 1989AS1B Asahi et al., Tokyo (1988) 173
- 1989AU1B Austin, Tokyo (1988) 331
- 1989AV02 V.V. Avdeichikov, A.I. Bogdanov, V.A. Budilov, V.Ya. Volkov, N.L. Gorshkova, K.G. Denisenko, V.N. Emelyanenko, N.K. Zhidkov, A. Kotus, S. Mruvchinsky et al., Yad. Fiz. 50 (1989) 409; Sov. J. Nucl. Phys. 50 (1989) 255
- 1989BA2P J.N. Bahcall, Neutrino Astrophys. (Publ. Cambridge Univ. Press 1989)
- 1989BA63 Yu.A. Batusov, N.I. Kostanashvili, V.I. Tretyak and Kh.M. Chernev, Yad. Fiz. 49 (1989) 1248; Sov. J. Nucl. Phys. 49 (1989) 777
- 1989BA64 G. Baur and M. Weber, Nucl. Phys. A504 (1989) 366
- 1989BA92 H. Bando, Nuovo Cim. A102 (1989) 627
- 1989BA93 H. Bando, M. Sano, J. Zoofka and M. Wakai, Nucl. Phys. A501 (1989) 900
- 1989BE03 G.F. Bertsch, B.A. Brown and H. Sagawa, Phys. Rev. C39 (1989) 1154
- 1989BE1P Berdnikov et al., Tashkent (1989) 293
- 1989BE1R Belyanin et al., in Tashkent (1989) 360
- 1989BE2K Besnogikh et al., AIP Conf. Proc. 187 (1989) 688
- 1989BEXT Yu.A. Berezhnoi, I.N. Kudryavtsev and A.P. Soznik, Ukr. Fiz. Zh. 34 (1989) 1481
- 1989BEXU Ya.A. Berdnikov and A.M. Makhov, Prog. and Thesis, Proc. 39th Ann. Conf. Nucl. Spectrosc. Struct. At. Nucl., Tashkent (1989) 440
- 1989BEXX Ya.A. Berdnikov, M.K. Zaitsev, V.I. Nikitchenko and V.I. Ostroumov, Prog. and Thesis, Proc. 39th Ann. Conf. Nucl. Spectrosc. Struct. At. Nucl., Tashkent (1989) 302
- 1989BH03 S. Bhattacharya, J.N. De, K. Krishan and S.K. Samaddar, Phys. Rev. Lett. 62 (1989) 2589
- 1989BL1D Blann and Remington, in Mikolajki (1989) 97
- 1989BO1M Boyd et al., Science 244 (1989) 1450
- 1989BR1J Brown, in Sao Paulo (1989) 187
- 1989BR1K Brancus et al., Sao Paulo (1989) 361
- 1989BR34 L. Brillard, A.G. Elayi, E. Hourani, M. Hussonnois, J.-F. Le Du, L.-H. Rosier and L. Stab, Compt. Rend. Acad. Sci., Ser. II 309 (1989) 1105
- 1989BR35 C. Brechtmann, W. Heinrich and E.V. Benton, Phys. Rev. C39 (1989) 2222

1989BU05 B. Buck and A.C. Merchant, J. Phys. G15 (1989) 615
 1989BU06 B. Buck and A.C. Merchant, Phys. Rev. C39 (1989) 2097
 1989BU1H Burgov and Kadmsky, Tashkent (1989) 185
 1989BU1I Buck and Merchant, Sao Paulo (1989) 151
 1989CA15 S. Cavallaro, S.Z. Yin, G. Prete and G. Viesti, Phys. Rev. C40 (1989) 98
 1989CA1J Carnoy et al., Wein 89 (1989) 581
 1989CEZZ D.A. Cebra, J. Clayton, S. Howden, J. Karn, A. Nadasen, C. Ogilvie, A. Vander Molen, G.D. Westfall, W.K. Wilson and J. Winfield, Bull. Amer. Phys. Soc. 34 (1989) 1221
 1989CH04 N.S. Chant and P.G. Roos, Phys. Rev. C39 (1989) 957
 1989CH1K Chuvilsky, Tashkent (1989) 414
 1989CH1O Ching et al., Commun. Theor. Phys. 11 (1989) 171
 1989CH1X Chen and Li, Astrophys. Space Sci. 158 (1989) 153
 1989CH1Z Charbonneau, Michaud and Proffitt, Astrophys. J. 347 (1989) 821
 1989CH31 A.A. Chumbalov, R.A. Eramzhyan and S.S. Kamalov, Czech. J. Phys. B39 (1989) 853
 1989CI03 N. Cindro and M. Bozin, Phys. Rev. C39 (1989) 1665
 1989CI1C Cindro and Bozin, "Heavy Ions in Nucl. and Atomic Phys.," 1988 Mikolajki Summer School on Nucl. Phys., Eds. Wilhelmi and Szefflinska; A. Hilger Publ. (1989) 239
 1989CRZX K. Cromer, B.L. Clausen, R.A. Lindgren, B.E. Norum, D. Dehnhard, M.K. Jones, S.K. Nanda, S.J. Seestrom-Morris, K.W. Jones, J.A. McGill et al., Bull. Amer. Phys. Soc. 34 (1989) 1829
 1989DE1J Degreve and Cugier, Astron. Astrophys. 211 (1989) 356
 1989DE1O Dem'yanova and Ogloblin, Tashkent (1989) 343
 1989DE1Q Dem'yanova and Ogloblin, Sao Paulo (1989) 278
 1989DE28 P. Descouvemont and D. Baye, Nucl. Phys. A500 (1989) 155
 1989DE34 A.S. Demyanova, J.M. Bang, F.A. Gareev, S.A. Goncharov, S.N. Ershov, A.A. Ogloblin and P.P. Korovin, Nucl. Phys. A501 (1989) 336
 1989DE52 C. Detraz and D.J. Vieira, Ann. Rev. Nucl. Part. Sci. 39 (1989) 407
 1989DI1B Distelbrink et al., Topical Wksp. Excited Baryons 1988, Troy, NY (1989) 362
 1989DO1B B. Doyle, B. Goulard and N.C. Mukhopadhyay, in Wein 89 (1989) 673
 1989DO1I C.B. Dover, D.J. Millener and A. Gal, Phys. Rept. 184 (1989) 1
 1989DO1K Dover, Millener and Gal, Phys. Rept. 184 (1989) 1
 1989DO1L Doyle, in Troy (1989) 373

- 1989DR03 P.V. Drumm, L.K. Fifield, R.A. Bark, M.A.C. Hotchkis and C.L. Woods, Nucl. Phys. A496 (1989) 530
- 1989DU1B Dufour, Rev. Mex. Astron. Astrofis. 18 (1989) 87
- 1989EL05 C. Ellegaard, C. Gaarde, T.S. Jorgensen, J.S. Larsen, B. Million, C. Goodman, A. Brockstedt, P. Ekstrom, M. Osterlund, M. Bedjidian et al., Phys. Lett. 231B (1989) 365
- 1989ER05 S.N. Ershov, F.A. Gareev, R.S. Kurmanov, E.F. Svinareva, G.S. Kazacha, A.S. Demyanova, A.A. Ogloblin, S.A. Goncharov, J.S. Vaagen and J.M. Bang, Phys. Lett. 227B (1989) 315
- 1989FE06 P.B. Fernandez, E.G. Adelberger and A. Garcia, Phys. Rev. C40 (1989) 1887
- 1989FL1A Florescu, Holan and Sandulescu, Rev. Roum. Phys. 34 (1989) 595
- 1989GA09 C. García-Recio, M.J. Lopez, J. Navarro and F. Roig, Phys. Lett. B222 (1989) 329
- 1989GA1H Gaydaenko et al., Tashkent (1989) 366
- 1989GA1I Gareev et al., Tashkent (1989) 466
- 1989GE10 P.M. Gensini, Nuovo Cim. A102 (1989) 1563
- 1989GE11 C.K. Gelbke, Nucl. Phys. A495 (1989) C27
- 1989GIZV Yu.R. Gismatullin, A.A. Melentev, A.M. Petukhov and V.I. Ostroumov, in Tashkent (1989) 306
- 1989GIZW Yu.R. Gismatullin, A.V. Kononykhin, A.A. Melentev, V.I. Ostroumov and M.A. Stalovich, Prog. and Thesis, Proc. 39th Ann. Conf. Nucl. Spectrosc. Struct. At. Nucl., Tashkent (1989) 300
- 1989GO14 S.A. Goncharov, I.R. Gulamov, E.A. Romanovsky, N.K. Timofeyuk and K.V. Shitikova, J. Phys. G15 (1989) 1431
- 1989GOZN S.A. Goncharov, O. Su Ir and E.A. Romanovsky, Prog. and Thesis, Proc. 39th Ann. Conf. Nucl. Spectrosc. Struct. At. Nucl., Tashkent (1989) 359
- 1989GOZQ N.G. Goncharova, Prog. and Thesis, Proc. 39th Ann. Conf. Nucl. Spectrosc. Struct. At. Nucl., Tashkent (1989) 154
- 1989GRZQ W. Greiner, M. Ivascu, D.N. Poenaru and A. Sandulescu, Treatise on Heavy-Ion Sci. 8 (1989) 641; Ed. Bromlev, published by Plenum Publ. Corp. 1989
- 1989GU1B Gupta, Wein (1989) Paper PG02
- 1989GU1J N. Guessoum, Astrophys. J. 345 (1989) 363
- 1989GU1L Gustafsson, Ann. Astron. Astrophys. 27 (1989) 701
- 1989GU1Q Gupta and Webber, Astrophys. J. 340 (1989) 1124
- 1989GU28 N. Guessoum and R.J. Gould, Astrophys. J. 345 (1989) 356
- 1989HA1X Hardy, Wein 89 (1989) 35

- 1989HE04 R. Heaton, H. Lee, P. Skensved and B.C. Robertson, Nucl. Instrum. Meth. Phys. Res. A276 (1989) 529
- 1989HO16 E. Hourani, M. Hussonnois and D.N. Poenaru, Ann. Phys. 14 (1989) 311
- 1989HO1F Hollowell and Iben, Astrophys. J. 340 (1989) 966
- 1989HO1H R. Hou, X. Zhao and Z. Zhu, Commun. Theor. Phys. 12 (1989) 57
- 1989IE01 M. Ieiri, H. Sakaguchi, M. Nakamura, M. Yosoi, T. Ichihara, Y. Takeuchi, H. Togawa, T. Tsutsumi, S. Hirata, T. Nakano et al., Nucl. Phys. A504 (1989) 477
- 1989IT04 K. Itonaga, Nuovo Cim. 102A (1989) 501
- 1989JE01 H. Jelitto, J. Buschmann, V. Corcalciuc, H.J. Gils, N. Heide, J. Kiener, H. Rebel, C. Samanta and S. Zagromski, Z. Phys. A332 (1989) 317
- 1989JI1A L. Jin, W.D. Arnett and S.K. Chakrabarti, Astrophys. J. 336 (1989) 572
- 1989JO07 M.B. Johnson, Czech. J. Phys. B39 (1989) 822
- 1989KA1K Kajino, Mathews and Fuller, in Tokyo 1988 (1989) 51
- 1989KE1D Kerridge, Science 45 (1989) 480
- 1989KEZZ S.E. Kellogg, R.B. Vogelaar and R.W. Kavanagh, Bull. Amer. Phys. Soc. 34 (1989) 1192
- 1989KH08 Khankhasayev, Czech. J. Phys. 39 (1989) 836
- 1989KI13 A. Kiss, F. Deák, Z. Seres, G. Caskey, A. Galonsky, B. Remington and L. Heilbronn, Nucl. Phys. A499 (1989) 131
- 1989KO21 E. Korkmaz, S.E. Vigdor, W.W. Jacobs, T.G. Throwe, L.C. Bland, M.C. Green, P.L. Jolivet and J.D. Brown, Phys. Rev. C40 (1989) 813
- 1989KO37 C.G. Koutroulos, J. Phys. G15 (1989) 1659
- 1989KU07 I.N. Kudryavtsev and A.P. Soznik, Yad. Fiz. 49 (1989) 229; Sov. J. Nucl. Phys. 49 (1989) 146
- 1989KU14 I.N. Kudryavtsev and A.P. Soznik, J. Phys. G15 (1989) 1377
- 1989KU32 I.N. Kudryavtsev and A.P. Soznik, Ukr. Fiz. Zh. 34 (1989) 1642
- 1989LE11 M.J. Leitch, H.W. Baer, R.L. Burman, C.L. Morris, J.N. Knudson, J.R. Comfort, D.H. Wright, R. Gilman, S.H. Rokni, E. Piasezky et al., Phys. Rev. C39 (1989) 2356
- 1989LE1L Leitch, "Fund. Symm. and Nucl. Struct.", Eds. Ginocchio and Rosen, in Santa Fe, NM 1988 (World Scientific: 1989) 163
- 1989LI26 A. Li, H.G. Pfutzner, C.R. Howell and R.L. Walter, Chin. J. Nucl. Phys. 11 (1989) 1
- 1989LO14 W.R. Lozowski, Nucl. Instrum. Meth. Phys. Res. A282 (1989) 54
- 1989LO1E Loschakov, Golovin and Vdovin, Tashkent (1989) 275
- 1989MA21 S.S. Malik and R.K. Gupta, Phys. Rev. C39 (1989) 1992

- 1989MA43 S.S. Malik, S. Singh, R.K. Puri, S. Kumar and R.K. Gupta, *Pramana* 15 (1989) 419
- 1989MA45 Z. Majka, V. Abenante, Z. Li, N.G. Nicolis, D.G. Sarantites, T.M. Semkow, L.G. Sobotka, D.W. Stracener, J.R. Beene, D.C. Hensley et al., *Phys. Rev. C* 40 (1989) 2124
- 1989MAZP D.G. Marchlinski, P. Kernan, J. Kruzan, E. Sugarbaker, R.C. Byrd, T.A. Carey, J.B. McClelland, L.J. Rybarczyk, T.N. Taddeucci, C.D. Goodman et al., *Bull. Amer. Phys. Soc.* 34 (1989) 1829
- 1989ME1C Mewaldt and Stone, *Astrophys. J.* 337 (1989) 959
- 1989MU1A Murphy et al., *Nature* 337 (1989) 153
- 1989MU1G Mukhopadhyay, *Wein* 89 (1989) 51
- 1989NA01 J. Navarro and F. Roig, *Phys. Rev. C* 39 (1989) 302
- 1989NA1R Nakashima et al., *Int. Conf. Nucl. Reaction Mechanism, Calcutta, India* (1989) 422
- 1989NI1C Niita et al., *Nucl. Phys. A* 495 (1989) 91c
- 1989NI1D H. Nifenecker and J.A. Pinston, *Prog. Part. Nucl. Phys.* 23 (1989) 271
- 1989NO1A Nomoto, Hashimoto, Arai and Kaminisi, *Proc. int. Symp. on Heavy Ion Phys. and Nucl. Astrophys. Problems, Tokyo, 21-23 July 1988*, Ed. S. Kubono, M. Ishihara and T. Nomura (1989) 9
- 1989OG1B A.A. Oglobin and Y.E. Penionzhkevich, *Treatise On Heavy-Ion Science, Vol. 8*, Ed. D.A. Bromley (1989) 261
- 1989OK02 H. Okamura, A. Sakaguchi, S. Hatori, H. Sakai, N. Matsuoka, M. Fujiwara, T. Noro, T. Motobayashi, S. Satoh, A. Okihana et al., *Phys. Lett. B* 227 (1989) 204
- 1989OR01 W.E. Ormand and B.A. Brown, *Phys. Rev. Lett.* 62 (1989) 866
- 1989OR02 W.E. Ormand and B.A. Brown, *Nucl. Phys. A* 491 (1989) 1
- 1989OR09 W.E. Ormand, B.A. Brown and B.R. Holstein, *Phys. Rev. C* 40 (1989) 2914
- 1989PL05 M.A. Plum, R.A. Lindgren, J. Dubach, R.S. Hicks, R.L. Huffman, B. Parker, G.A. Peterson, J. Alster, J. Lichtenstadt, M.A. Moinester et al., *Phys. Rev. C* 40 (1989) 1861
- 1989PO05 I.V. Poplavsky, *Yad. Fiz.* 49 (1989) 408; *Sov. J. Nucl. Phys.* 49 (1989) 253
- 1989PO06 N.T. Porile, A.J. Bujak, D.D. Carmony, Y.H. Chung, L.J. Gutay, A.S. Hirsch, M. Mahi, G.L. Paderewski, T.C. Sangster, R.P. Scharenberg et al., *Phys. Rev. C* 39 (1989) 1914
- 1989PO07 J. Pouliot, Y. Chan, A. Dacal, D.E. DiGregorio, B.A. Harmon, R. Knop, M.E. Ortiz, E. Plagnol, R.G. Stokstad, C. Moisan et al., *Phys. Lett. B* 223 (1989) 16
- 1989PO18 D.N. Poenaru, W. Greiner and M. Ivascu, *Nucl. Phys. A* 502 (1989) C59
- 1989PO1I Poenaru et al., *Sao Paulo* (1989) 144

- 1989PO1K Poppelier, Ph.D. Thesis, Univ. of Utrecht (1989)
- 1989PR02 C. Pruneau, L. Potvin, R. Roy, C. St-Pierre, G.C. Ball, R. Bougault, E. Hagberg, D. Horn, D. Cebra, D. Fox et al., Nucl. Phys. A500 (1989) 168
- 1989PR06 P.B. Price, Nucl. Phys. A502 (1989) C41
- 1989PR1D Proffitt and Michaud, Astrophys. J. 345 (1989) 998
- 1989PR1F Price, Ann. Rev. Nucl. Part. Sci. 39 (1989) 19
- 1989PU01 V. Punjabi, C. F. Perdrisat, P. Ulmer, C. Lyndon, J. Yonnet, R. Beurtey, M. Boivin, F. Plouin, J. P. Didelez, R. Frascaria et al., Phys. Rev. C39 (1989) 608
- 1989RA09 J. Rapaport, P.W. Lisowski, J.L. Ullmann, R.C. Byrd, T.A. Carey, J.B. McClelland, L.J. Rybarcyk, T.N. Taddeucci, R.C. Haight, N.S.P. King et al., Phys. Rev. C39 (1989) 1929
- 1989RA15 L. Ray and J.R. Shepard, Phys. Rev. C40 (1989) 237
- 1989RA16 S. Raman, C.W. Nestor, Jr. , S. Kahane and K.H. Bhatt, At. Data Nucl. Data Tables 42 (1989) 1
- 1989RA17 P. Raghavan, At. Data Nucl. Data Tables 42 (1989) 189
- 1989RA1G J. Rapaport, Santa Fe 88 (1989) 186
- 1989RA1O Ray, Proc. Wksp. Relativistic Nucl. Many-Body Phys., Columbus, OH 1988 (1989) 427
- 1989RE01 D.A. Resler, H.D. Knox, P.E. Koehler, R.O. Lane and G.F. Auchampaugh, Phys. Rev. C39 (1989) 766
- 1989RI05 J. Riedlberger, C. Amsler, M. Doser, U. Straumann, P. Truol, D. Bailey, S. Barlag, U. Gastaldi, R. Landua, C. Sabev et al., Phys. Rev. C40 (1989) 2717
- 1989RO22 N. Rowley, A. Kabir and R. Lindsay, J. Phys. G15 (1989) L269
- 1989SA10 M.G. Saint-Laurent, R. Anne, D. Bazin, D. Guillemaud-Mueller, U. Jahnke, Jin Gen-Ming, A.C. Mueller, J.F. Bruandet, F. Glasser, S. Kox et al., Z. Phys. A332 (1989) 457
- 1989SA13 S.K. Saha, W.W. Daehnick, S.A. Dytman, P.C. Li, J.G. Hardie, G.P.A. Berg, C.C. Foster, W.P. Jones, D.W. Miller and E.J. Stephenson, Phys. Rev. C40 (1989) 39
- 1989SA1L Sandulescu, J. Phys. G15 (1989) 529
- 1989SA1P Sakutal, Tashkent (1989) 380
- 1989SA45 A. Sandulescu, A. Florescu and W. Greiner, J. Phys. G15 (1989) 1815
- 1989SH05 W.-Q. Shen, B. Wang, J. Feng, W.-L. Zhan, Y.-T. Zhu and E.-P. Feng, Nucl. Phys. A491 (1989) 130
- 1989SH1G Shvedov, Berdnichenko and Zerkin, Tashkent (1989) 398
- 1989SH37 Y. Shi and W.J. Swiatecki, Chin. J. Nucl. Phys. 11 (1989) 31

- 1989SI09 A.A. Sibirtsev and Yu.V. Trebukhovsky, *Yad. Fiz.* 49 (1989) 1001; *Sov. J. Nucl. Phys.* 49 (1989) 622
- 1989SI1B Siciliano, Johnson and Sarafian, *Bull. Amer. Phys. Soc.* 34 (1989) 1204
- 1989SI1D Siciliano, Johnson and Sarafian, *Bull. Amer. Phys. Soc.* 34 (1989) 1814
- 1989SOZY D.S. Sorenson, X. Aslanoglou, F.P. Brady, J.R. Drummond, R.W. Finlay, R.C. Haight, C. Howell, N.S.P. King, A. Ling, P.W. Lisowski et al., *Bull. Amer. Phys. Soc.* 34 (1989) 1233
- 1989SP01 R.H. Spear, *At. Data Nucl. Data Tables* 42 (1989) 55
- 1989ST1D Stuver and Braziunas, *Nature* 338 (1989) 405
- 1989ST1H Strottman, *Fund. Symm. and Nucl. Struct.*, Eds. Ginocchio and Rosen, in Santa Fe, NM 1988 (1989) 247
- 1989STZW P.A. Staples, J.J. Egan, G.H.R. Kegel, A. Mittler and D.J. Desimone, *Bull. Amer. Phys. Soc.* 34 (1989) 1831
- 1989SU1A Sugarbaker and Marchlenski, *Weak and Electro-Magnetic Interactions in Nuclei. Proc. Int. Symp. (Wein-89), Montreal, Que., Canada, May, 1989*; Eds. *Frontieres* (1989) 623
- 1989SU1E Sukhorutshkin, Tashkent (1989) 213
- 1989SU1J Sugarbaker and Marchlenski, *Wein 89 (1989) Paper PB09*
- 1989SUZS T. Suzuki, T. Kobayashi, T. Kubo, T. Nakagawa, T. Ichihara, M. Fukuda, K. Yoshida and I. Tanihata, *RIKEN-88 (1989) 8*; Sao Paulo (1989) 388
- 1989TA01 I. Talmi, *Phys. Rev.* C39 (1989) 284
- 1989TA1K Tanihata, Tokyo (1988) 185
- 1989TA2S Tanihata, *Bull. Amer. Phys. Soc.* 34 (1989) 1820
- 1989TE02 F. Terrasi, A. Brondi, G. La Rana, G. De Angelis, A. D'Onofrio, R. Moro, E. Perillo and M. Romano, *Phys. Rev.* C40 (1989) 742
- 1989VA07 O.I. Vasileva, G.S. Gurevich, A.V. Ignatenko, V.M. Lebedev, N.V. Orlova, A.V. Spassky, I.B. Teplov, G.V. Shakhvorostova and I.K. Shestakova, *Yad. Fiz.* 49 (1989) 625; *Sov. J. Nucl. Phys.* 49 (1989) 387
- 1989VA21 D. Vartsky, M.B. Goldberg, G. Engler, A. Goldschmidt, A. Breskin, R.E. Morgado, C. Hollas, L. Ussery, B.L. Berman and C. Moss, *Nucl. Phys.* A505 (1989) 328
- 1989VO05 B. von Przewoski, P.D. Eversheim, F. Hinterberger, L. Doberitz, J. Campbell, M. Hammans, R. Henneck, W. Lorenzon, M.A. Pickar and I. Sick, *Nucl. Phys.* A496 (1989) 15
- 1989VO19 V.I. Voloshchuk, I.V. Dogyust, V.V. Kirichenko and A.F. Khodyachikh, *Ukr. Fiz. Zh.* 34 (1989) 511
- 1989VO1D von Oertzen, Tokyo (1988) 373

- 1989VOZM V.V. Volkov, *Treatise on Heavy-Ion Science*, Plenum Press, New York, Vol. 8 (1989)101
- 1989WA16 S. Wa-Kitwanga, P. Leleux, P. Lipnik and J. Vanhorenbeeck, *Phys. Rev. C*40 (1989) 35
- 1989WH1B Wheeler, Sneden and Truran, *Ann. Rev. Astron. Astrophys.* 27 (1989) 279
- 1989WI02 A.L. Williams, L. Agnew, L.G. Atencio, H.W. Baer, M. Burlein, G.R. Burtleson, K.S. Dhuga, H.T. Fortune, G.S. Kyle, J.A. McGill et al., *Phys. Lett. B*216 (1989) 11
- 1989WO1E Wolters, Ph.D. Thesis, Univ. of Utrecht (1989)
- 1989WY1A Wyckoff et al., *Astrophys. J.* 339 (1989) 488
- 1989YO02 A. Yokoyama, T. Saito, H. Baba, K. Hata, Y. Nagame, S. Ichikawa, S. Baba, A. Shinohara and N. Imanishi, *Z. Phys. A*332 (1989) 71
- 1989YU1A Yu, Cai and Ma, Sao Paulo (1989) 9
- 1989ZHZY X.L. Tu, V.G. Lind, D.J. Vieira, J.M. Wouters, K.E.G. Lobner, Z.Y. Zhou, H.L. Seifert, *Bull. Amer. Phys. Soc.*34 (1989) 1800
- 1990AJ01 F. Ajzenberg-Selove, *Nucl. Phys. A*506 (1990) 1.
- 1990AR1E Ardisson and Hussonnois, *Comptesrendus Acad. Sci. Ser. II Mec. Phys.* 310 (1990) 367
- 1990BE24 C. Bennhold and L. Tiator, *Phys. Rev. C*42 (1990) 464
- 1990BO04 J. Boger, S. Kox, G. Auger, J.M. Alexander, A. Narayanan, M.A. McMahan, D.J. Moses, M. Kaplan and G.P. Gilfoyle, *Phys. Rev. C*41 (1990) R801
- 1990BO11 B. Bonin, A. Boudard, H. Fanet, R.W. Ferguson, M. Garcon, C. Giorgetti, J. Habault, J. Le Meur, R.M. Lombard, J.C. Lugol et al., *Nucl. Instrum. Meth. Phys. Res. A*288 (1990) 389
- 1990BR1S Brown, Warburton and Wildenthal, MSUCL-715 (1990)
- 1990BU09 B. Buck and A.C. Merchant, *J. Phys. G*16 (1990) 185
- 1990BU13 B. Buck, A.C. Merchant and S.M. Perez, *Nucl. Phys. A*512 (1990) 483
- 1990CA1S Cassing et al., *Phys. Rept.* 188 (1990) 363
- 1990CA1U Carnoy et al., Panic XII (1990) Paper XII-11
- 1990CH12 H.C. Chiang, E. Oset, R.C. Carrasco, J. Nieves and J. Navarro, *Nucl. Phys. A*510 (1990) 573; Errata *Nucl. Phys. A*514 (1990) 749
- 1990CH13 H.C. Chiang, E. Oset and P. Fernandez de Cordoba, *Nucl. Phys. A*510 (1990) 591
- 1990CH14 C. Ching, T. Ho and B. Zou, *Nucl. Phys. A*510 (1990) 630
- 1990CH1S Chaing et al., in Panic XII (1990) Paper III-59
- 1990CL02 B.L. Clausen, J.T. Brack, M.R. Braunstein, J.J. Kraushaar, R.A. Loveman, R.J. Peterson, R.A. Ristinen, R.A. Lindgren and M.A. Plum, *Phys. Rev. C*41 (1990) 2246

- 1990DE13 G.Delic, Phys. Rev. C41 (1990) 2032
- 1990DE14 A. De Rosa, E. Fioretto, G. Inghima, M. Romoli, M. Sandoli, R. Setola, G. Cardella, M. Papa, G. Pappalardo, F. Rizzo et al., Phys. Rev. C41 (1990) 2062
- 1990DI1D Distelbrink et al., Panic XII (1990) Paper I-28
- 1990DO1C Donahue, Jull and Linick, Nucl. Instrum. Meth. Phys. Res. B45 (1990) 561
- 1990DU01 O. Dumitrescu, M. Horoi, F. Carstoiu and G. Stratan, Phys. Rev. C41 (1990) 1462
- 1990ER03 R.A. Eramzhyan, M. Gmitro and S.S. Kamalov, Phys. Rev. C41 (1990) 2865
- 1990ER1E R.A. Eramzhyan, M. Gmitro and S.S. Kamalov, Panic XII (1990) Paper III-60
- 1990GA1M Gallant, Crawford and Dubach, Panic XII (1990) Paper I-53
- 1990GH01 L. Ghedira, D. Myers, B.H. Cottman, K. Sankhavaram, M.D. Seneviratne, P. Stoler, E.J. Winhold, M. Yamazaki, P.F. Yergin, J.H.J. Distelbrink et al., Phys. Rev. C41 (1990) 653
- 1990GH1F Ghosh et al., Europhys. Lett. 11 (1990) 535
- 1990GL01 A. Glaesner, W. Dunnweber, M. Bantel, W. Hering, D. Konnerth, R. Ritzka, W. Trautmann, W. Trombik and W. Zipper, Nucl. Phys. A509 (1990) 331
- 1990GOZZ W.G. Gong, N. Carlin, R.T. de Souza, C.K. Gelbke, Y.D. Kim, W.G. Lynch, T. Murakami, D. Sanderson, M.B. Tsang, H.M. Xu et al., Bull. Amer. Phys. Soc. 35 (1990) 948
- 1990GR1G Grebinnik et al., JETP Lett. 51 (1990) 6
- 1990HA07 W.C. Haxton, Nucl. Phys. A507 (1990) 179c
- 1990HA13 J.C. Hardy, I.S. Towner, V.T. Koslowsky, E. Hagberg and H. Schmeing, Nucl. Phys. A509 (1990) 429
- 1990HA1Q Hardy, Bull. Amer. Phys. Soc. 35 (1990) 1033
- 1990HA46 D. Harley, B. Muller and J. Rafelski, J. Phys. G16 (1990) 281
- 1990HAZV Q. Haider and L.C. Liu, Bull. Amer. Phys. Soc. 35 (1990) 1017
- 1990HO06 G.W. Hoffmann, M.L. Barlett, D. Ciskowski, G. Pauletta, M. Purcell, L. Ray, J.F. Amann, J.J. Jarmer, K.W. Jones, S. Pentilla et al., Phys. Rev. C41 (1990) 1651
- 1990HO1C Holtkamp et al., Phys. Rev. C41 (1990) 1319
- 1990HO1I Hollowell and Iben, Astrophys. J. 349 (1990) 208
- 1990HO1L Hoffman et al., Panic XII (1990) Paper II-10
- 1990HU02 M. Hussonnois, J.F. Le Du, L. Brillard and G. Ardisson, J. Phys. G16 (1990) L77
- 1990HY01 S.D. Hyman, D.J. Mack, H. Breuer, N.S. Chant, F. Khazaie, B.G. Ritchie, P.G. Roos, J.D. Silk, P.-A. Amaudruz, Th.S. Bauer et al., Phys. Rev. C41 (1990) R409

- 1990IE01 K. Ieki, J. Iimura, M. Iwase, H. Ohnuma, H. Shimizu, H. Toyokawa, K. Furukawa, H. Kabasawa, T. Nakagawa, T. Tohei et al., Phys. Rev. C42 (1990) 457
- 1990IT1A Itonaga, Motoba and Bando, Panic XII (1990) Paper IV-15
- 1990JO01 T.M. Jorgensen, A.S. Jensen, A. Miranda and G.C. Oades, Nucl. Phys. A506 (1990) 615
- 1990KO10 T.S. Kosmas and J.D. Vergados, Nucl. Phys. A510 (1990) 641
- 1990KO21 F. Kohl, J. Krauskopf, P. Misaelides, R. Michelmann, G. Wolf and K. Bethge, Nucl. Instrum. Meth. Phys. Res. B50 (1990) 19
- 1990LE08 J.H. Lee, W. Benenson and D.J. Morrissey, Phys. Rev. C41 (1990) 1562
- 1990LO10 R.J. Lombard, Europhys. Lett. 12 (1990) 119
- 1990MA1P Malaney, Meyer and Butler, Astrophys. J. 352 (1990) 767
- 1990MU10 A.M. Mukhamedzhanov and N.K. Timofeyuk, Yad. Fiz. 51 (1990) 679; Sov. J. Nucl. Phys. 51 (1990) 431
- 1990OE1C Oeschger and Beer, Phil. Trans. Royal Soc. London A330 (1990) 471
- 1990OG01 A.A. Ogloblin, N.I. Venikov, S.K. Lisin, S.V. Pirozhkov, V.A. Pchelin, Yu.F. Rodionov, V.M. Semochkin, V.A. Shabrov, I.K. Shvetsov, V.M. Shubko et al., Phys. Lett. B235 (1990) 35
- 1990OL01 N. Olsson, E. Ramstrom and B. Trostell, Nucl. Phys. A509 (1990) 161
- 1990PA01 S.J. Padalino, M.A. Putnam, J.A. Constable, T.G. Declerk, L.C. Dennis, R. Zingarelli, R. Kline and K. Sartor, Phys. Rev. C41 (1990) 594
- 1990PI05 S. Piskor and W. Schaferlingova, Nucl. Phys. A510 (1990) 301
- 1990PR01 C. Providencia and D. Brink, Nucl. Phys. A507 (1990) 426
- 1990PR1B Prasad, Chatterjee and Roy, Indian J. Pure Appl. Phys. 28 (1990) 40
- 1990RA03 S. Raman, M. Igashira, Y. Dozono, H. Kitazawa, M. Mizumoto and J.E. Lynn, Phys. Rev. C41 (1990) 458
- 1990RE04 Z. Ren and G.Xu, Phys. Lett. B237 (1990) 1
- 1990RO1E Roby and Lambert, Astrophys. J. Suppl. Ser. 73 (1990) 67
- 1990SA1J A. Sarkar, R. Ramesh, S.K. Bhattacharya and G. Rajagopalan, Nature 343 (1990) 549
- 1990SC10 Schumacher et al., Int. Conf. Part. Nucl., Cambridge, Mass., 25-29 June 1990 (Organizing Committee, 1990) Paper III-50
- 1990SH01 G. Shanmugam and B. Kamalaharan, Phys. Rev. C41 (1990) 1184
- 1990SI1A Silberberg and Tsao, Astrophys. J. 352 (1990) L49
- 1990SMZZ M.S. Smith, P.V. Magnus, R.M. Curley, P.D. Parker, T.F. Wang, P.B. Fernandez, S.J. Sanders and E.G. Adelberger, Bull. Amer. Phys. Soc. 35 (1990) 1074

- 1990SP02 R.A. Spits, W. Baloyi and T.E. Derry, Phys. Rev. C41 (1990) 2429
- 1990TA1J Taddeucci et al., Panic XII (1990) Paper II-1
- 1990TH1C F.-K. Thielemann, M.-A. Hashimoto and K. Nomoto, Astrophys. J. 349 (1990) 222
- 1990TO10 S.Y. Tong, W.N. Lennard, P.F.A. Alkemade and I.V. Mitchell, Nucl. Instrum. Meth. Phys. Res. B45 (1990) 91
- 1990VA01 A.G.M. Van Hees, J.G.L. Booten and P.W.M. Glaudemans, Nucl. Phys. A507 (1990) 55c
- 1990VA1G van Dyck, Bull. Amer. Phys. Soc. 35 (1990) 944
- 1990VO02 B. von Przewoski, P.D. Eversheim, F. Hinterberger, U. Lahr, J. Campbell, J. Gotz, M. Hammans, R. Henneck, G. Masson, I. Sick et al., Phys. Rev. Lett. 64 (1990) 368
- 1990VO1E von Oertzen, Nucl. Instrum. Meth. Phys. Res. A287 (1990) 188
- 1990WE01 D. Weselka, P. Hille and A. Chalupka, Phys. Rev. C41 (1990) 778
- 1990WE14 W.R. Webber, J.C. Kish and D.A. Schrier, Phys. Rev. C41 (1990) 520
- 1990WE1I W.R. Webber, A. Soutoul, P. Ferrando and M. Gupta, Astrophys. J. 348 (1990) 611
- 1990WI05 D.H. Wilkinson, Nucl. Phys. A511 (1990) 301
- 1990WI10 D.H. Wilkinson, Phys. Lett. B241 (1990) 317
- 1990WI1J Wilkinson, Panic XII (1990) Paper XII-1
- 1990WIZV V. Wijekumar, H.R. Weller, G. Feldman, J.Z. Williams and D.R. Tilley, Bull. Amer. Phys. Soc. 35 (1990) 1058
- 1990YA01 M. Yasue, M.H. Tanaka, T. Hasegawa, K. Nisimura, H. Ohnuma, H. Shimizu, K. Ieki, H. Toyokawa, M. Iwase, J. Iimura et al., Nucl. Phys. A509 (1990) 141
- 1990YA02 M. Yasue, M.H. Tanaka, T. Hasegawa, K. Nisimura, S. Kubono, H. Ohnuma, H. Shimizu, K. Ieki, H. Toyokawa, M. Iwase et al., Nucl. Phys. A510 (1990) 285
- 1990YE02 S.J. Yennello, K. Kwiatkowski, S. Rose, L.W. Woo, S.H. Zhou and V.E. Viola, Phys. Rev. C41 (1990) 79

